

BALL AND ROLLER BEARINGS



CATALOG A-1000-XI

NTN®



BALL AND ROLLER BEARINGS

CATALOG A-1000-XI



NTN Terms and Conditions of Sale

Offer; Acceptance. These terms and conditions (these “Terms”) are deemed part of all quotations, acknowledgments, invoices, purchase orders and other documents relating to the sale of goods and services (the “Goods”) by Seller. If these Terms differ in any way from any purchase order, release or other document from Buyer, these Terms shall be construed as a counteroffer and will not be effective as an acceptance of any other term except on the express condition that Buyer assents to these Terms; provided that Buyer is deemed to have accepted these Terms upon the earlier of 10 days after receipt without objection and acceptance by Buyer of any Goods.

Warranties. (a) **Exclusive Warranty.** The exclusive Seller warranty is that the Goods are free from defects in materials and workmanship. This warranty is extended solely to Buyer and not to any successive buyers, users or other third parties. SELLER MAKES NO WARRANTY OR REPRESENTATION, EXPRESS OR IMPLIED, ABOUT THE MERCHANTABILITY OR FITNESS FOR A PARTICULAR PURPOSE OF THE GOODS. BUYER ACKNOWLEDGES THAT IT ALONE HAS DETERMINED THAT THE GOODS WILL SUITABLY MEET THE REQUIREMENTS OF THEIR INTENDED USE. SELLER DISCLAIMS ALL OTHER EXPRESS WARRANTIES. (b) **Buyer Remedy.** The exclusive remedy of Buyer as to any Good is that Seller shall repair or replace (at Seller’s option) the Good (with Buyer responsible for labor charges for removal or replacement thereof), such obligation being subject to the following: (i) the Good’s application was approved by Seller; (ii) Buyer delivers the Good to Seller with transportation charges prepaid; and (iii) analysis by Seller verifies that the Good was properly handled, installed, maintained, lubricated and not subject to abuse, misuse or inappropriate modification. (c) **Damage Limits; Etc.** SELLER SHALL NOT BE LIABLE FOR SPECIAL, INDIRECT OR CONSEQUENTIAL DAMAGES, LOSS OF PROFITS OR COMMERCIAL LOSS IN ANY WAY CONNECTED WITH THE GOODS, WHETHER SUCH CLAIM IS BASED IN CONTRACT, WARRANTY, NEGLIGENCE OR STRICT LIABILITY. Further, in no event shall liability of Seller for any act exceed the price of the Good on which liability is asserted. Buyer must commence any action within one year after the sale of such Good by Seller.

Delivery; Packaging. (a) **Dates.** Delivery and shipment dates are estimated dates only. (b) **Partial Shipment; Etc.** Each partial shipment is deemed a separate contract for the delivered Goods. (c) **Shipment Terms.** All shipments are freight collect - FOB shipping point and Seller reserves the right to select transportation methods and routing. (d) **Packaging.** Seller will package Goods as it deems proper for protection against normal handling and extra charges apply to special conditions. (e) **Risk of Loss.** Risk of loss will pass to Buyer upon tender by Seller at the point of shipment defined as Seller’s dock.

Pricing; Payment; Etc. (a) **Pricing.** Prices are subject to change without notice, and prices in effect on the shipping date will govern. Any increases in freight rates or transportation charges before shipment will be for Buyer’s account. Prices also are subject to increase for any taxes, duties (including dumping duties) or other charges imposed on Seller by any governmental authority for the sale, delivery or use of the Goods. (b) **Payment.** Terms of payment are net 30 days from the invoice date. If Buyer fails to make any payment when due or Seller otherwise deems itself insecure, Seller reserves the right to change terms of payment and discontinue shipments. Buyer agrees to pay Seller’s customary late and interest charges for any failed or late payments.

Inspection; Etc. Buyer promptly shall inspect all delivered Goods. If Buyer does not inspect any Goods within six days of delivery, Buyer is deemed to have waived its right to inspect and to accept the Goods. Buyer must report to Seller shortages or defective Goods within ten days of receipt. Buyer may not return Goods without Seller’s written consent, and Buyer’s acceptance shall be final and irrevocable.

Cancellation; Etc. Orders approved and accepted by Seller shall constitute firm commitments of Buyer and are not subject to cancellation or rescheduling. Orders for non-standard Goods not listed in Seller’s catalogs may not be canceled at all, nor will Seller accept return of such Goods for credit.

Indemnities. Buyer shall indemnify and hold harmless Seller, its employees and representatives from and against all liabilities, claims, actions, costs, expenses and disbursements (including attorney’s fees and disbursements) related to any investigation, litigation or other proceeding (whether or not Seller is a party thereto) which arises or is alleged to arise from Buyer’s acts or omissions under these Terms. Without limiting the foregoing, Buyer shall indemnify and hold harmless Seller and defend or settle any action brought against Seller to the extent that it is based on a claim that any Good made to Buyer specifications infringed intellectual property rights of another party.

Confidentiality; Inventions. (a) **Confidentiality.** All information and materials supplied by Seller to Buyer relating to the Goods are confidential and proprietary, and Buyer shall limit distribution thereof to its trusted employees and use its best efforts to preserve the confidentiality thereof. (b) **Inventions; Etc.** If Seller or any of its affiliates makes a discovery or invention pertaining to any research, development or design work contemplated hereby, such discovery or invention shall be the sole property of Seller and licensing shall be at the discretion of Seller.

Force Majeure. Seller shall not be liable for any delay or failure in delivery resulting from causes beyond its control, including earthquakes, fires, floods, strikes or other labor disputes, shortage of labor or materials, accidents to machinery, acts of sabotage, riots, delay in or lack of transportation or the requirements of any government authority.

Miscellaneous. (a) **Waiver.** No failure or delay by Seller in exercising any right and no course of dealing between Buyer and Seller shall operate as a waiver of rights by Seller. (b) **Assignment.** Buyer may not assign its rights hereunder without the Seller’s written consent. (c) **Law.** This Agreement is governed by Illinois law (without regard to conflict of law principles). (d) **Amendment.** This Agreement constitutes the entire agreement between Buyer and Seller relating to the Goods, and no provision may be changed or waived unless in a writing signed by the parties. (e) **Severability.** If any provision hereof is rendered ineffective or invalid, such provision shall not invalidate any other provision. (f) **Setoff.** All claims hereunder by Seller are subject to setoff by Seller for any counterclaim arising out of any transaction with Buyer. (g) **Tooling; Etc.** All materials, equipment, facilities and special tooling Seller uses to manufacture Goods shall remain the property of Seller. (h) **Definitions.** “Including” means “including without limitation.”

Although care has been taken to assure the accuracy of the data compiled in this catalog, NTN does not assume any liability to any company or person for errors or omissions.



Table of Contents

General Information	4–11
Micro Bearings	12–15
Radial Ball Bearings	16–41
Angular Contact Ball Bearings	43–56
Self Aligning Ball Bearings	57–61
Cylindrical Roller Bearings	62–74
Tapered Roller Bearings	75–105
Spherical Roller Bearings	106–119
Adapters, Locknuts and Lockwashers	120–126
Ball and Roller Thrust Bearings	127–132
Mounted Units	133–237
Ultra Class – Mounted Units	135–155
Pillow Blocks – Standard Line	156–173
Flanged Units – Standard Line	174–203
Ball Bearing Inserts	204–221
Disc Harrow and Hex Bore Bearings	222–224
Heavy Duty Mounted Units	225–237
Technical Information	239–252
Tolerance and Clearance Tables	253–269
Interchange Data	270–275
Conversion & Decimal Equivalents Tables	276–277
General Index	278–279



NTN is one of the three largest bearing companies in the world. With facilities at the hub of industrial centers around the globe, NTN Bearing Corporation is in an enviable position to best serve its customers, both domestic and worldwide.

In North America, as in all our manufacturing facilities, we attain maximum efficiency using our automated production equipment and processes to produce quality high-volume standard bearing sizes. Low-volume bearings and sizes are manufactured in a single facility and then exported worldwide according to customer requirements. All bearing types and sizes currently used in North America are in inventory at warehouses across the continent.

To best serve our customers, NTN devotes all resources to a single objective: production of the finest quality ball and roller bearings. All of our plants use advanced processing and high speed automated production equipment, engineered and built by NTN, to support our capacity for ultra-high quality bearings. NTN's Statistical Process Control programs ensure

that during the production run, every bearing produced meets or exceeds AFBMA and ISO standards. Electro-mechanical quality inspection is present at every phase of manufacturing.

Proof of NTN's success at meeting our objective are the many quality awards received from our customers. Another cherished award was received in 1954 when NTN became the first bearing manufacturer to win the Deming Prize. This prestigious award is given for outstanding performance above all mechanical industries in statistical quality control, and efficiency of machinery and management. NTN's rigid quality standards originated with the company in 1918, and is the basis for every product innovation and corporate decision made today.

NTN's highly trained employees are here to serve your engineering, sales, and manufacturing needs. Customers receive unparalleled attention through technical assistance from over 700 engineers in North America, Europe and the Far East — all linked through 24-hour global communications. This

provides you with access to support from research and development engineers, application experts and field engineers. Our extensive testing and development laboratories keep us at the leading edge of bearing technology.

NTN became a world leader through attention to our customers' needs and constant technological innovations. Value-added bearings are NTN's forte.

Our quality level allows purchasers to take them directly from receiving dock to application, eliminating incoming inspection costs. They add value to your end product with longer lifetime, less downtime and less maintenance.





- | | | | |
|------|--|------|---|
| 1918 | Began research and manufacture of ball bearings at Nishizono Ironworks (Uchibori, Kuwana-cho, Kuwanagun, Mie Pref.) | 1972 | Renamed as NTN Toyo Bearing Co., Ltd.
Established NTN Product Development Institute.
NBCA Irvine, CA, office and warehouse occupied. |
| 1923 | Nishizono Ironworks and Tomoe Trading Co. (Nishiku, Osaka) inaugurated joint manufacture and sale of bearings under the brand name NTN. | 1973 | Established NTN Bearing Mfg. (Canada) Ltd. (Merged into NTN Bearing Corp. of Canada Ltd. in 1980.)
Constructed constant-velocity joint factory in Toyo Bearing Iwata Co., Ltd. |
| 1927 | NTN Mfg. Co., Ltd. established with capital of ~50, 000. | 1975 | Established NTN Elgin Corp. (U.S.A.). (Merged into American NTN Bearing Mfg. Corp. in 1985.)
New Takarazuka Plant completed.
NBCA Michigan sales office opened. |
| 1937 | Renamed the Toyo Bearing Mfg. Co., Ltd. | 1976 | NBCA Dallas sales office opened. |
| 1938 | Established Showa Bearing Mfg. Co., Ltd. (Muko-gun, Hyogo Pref.) | 1977 | NBCA Totowa, NJ, office and warehouse occupied. |
| 1939 | Kuwana Plant constructed.
Showa Bearing Mfg. Co., Ltd. merged to become Mukogawa Plant. | 1980 | NBCA Automitve Sales/Engineering Office established, Southfield, MI.
NBCA Distribution office and warehouse established, Mt. Prospect, IL. |
| 1950 | Established NTN Sales Co., Ltd. | 1981 | Research Departments reorganized into General Engineering Laboratory. |
| 1954 | Awarded Deming Prize for statistical quality control for the first time in the machinery industry. | 1982 | Constructed constant-velocity joint factory in Toyo Bearing Okayama Co. Ltd.
Constant Velocity joint technology licensed to Hyundai Motors (South Korea).
NBCA Norcross, GA, office and warehouse occupied. |
| 1960 | Established Toyo Bearing Iwata Co., Ltd.
Established NTN Walzlager (Europa). | 1983 | Constant velocity joint technology licensed to Lepco Co, Ltd. (Australia)
Merged with Toyo Bearing Iwata Co., Ltd. and Toyo Bearing Okayama Co., Ltd.
Constant velocity joint technology licensed to Taiway Ltd. (Taiwan)
NBCA Irving, TX, office and warehouse occupied.
NBCA Headquarters building expanded. (Des Plaines, IL)
NBCA Midwest and Central sales offices established. (Des Plaines, IL)
NBCA Peopria, IL, sales office opened. |
| 1962 | Constructed needle bearing factory in Toyo Bearing Iwata Co., Ltd.
Changed name of Muko-gawa Plant to Takarazuka Plant.
Established Toyo Bearing Machine Tool Laboratory Co., Ltd. | 1984 | Ground broken for Elgin, IL, tapered roller bearing manufacturing facility. |
| 1963 | Established NTN Bearing Corp. of America, New York.
Skokie, IL, office and warehouse opened. | | |
| 1964 | Established NTN France S.A.
Established NTN Bearings (UK) Ltd. | | |
| 1966 | Established NTN Powdered Metal Co., Ltd. | | |
| 1967 | Executed Technical Assistance Agreement with Tung Yang Bearing Mfg. Co., Ltd. (Taiwan)
NBCA Lincolnwood, IL, Head Office and warehouse established. | | |
| 1968 | Established NTN Bearing Corp. of Canada Ltd. | | |
| 1970 | NBCA California sales office opened. | | |
| 1971 | Established American NTN Bearing Mfg. Corp. (Schiller Park, IL)
Established NTN Trading-Hong Kong Ltd.
Established Toyo Bearing Okayama Co.,Ltd.
Established NTN Kugellagerfabrik. (Deutschland)
NBCA Atlanta sales office opened. | | |

- | | |
|---|---|
| <p>1985 Established Toyo Bearing Nagano Co. Ltd.
Bearing production technology licensed to National Engineering Industries Ltd. (India)
Established NTN-Bower Corporation, a joint venture with Federal-Mogul Corporation. (U.S.A.)</p> <p>1986 Constructed (in Kuwana Plant) Japan's first plant dedicated to aerospace bearings.</p> <p>1987 NTN-Bower Corporation became 100% owned affiliate.</p> <p>1988 Established NTN Technical Center (U.S.A.) Inc. (Ann Arbor, MI)
Established Unidrive Pty. Ltd., a joint venture manufacturer of constant velocity joints in Australia.
Ground broken for Elgin, IL, bearing hub unit manufacturing facility.</p> <p>1989 Built new building for R&D at Iwata Plant.
Merged with Toyo Bearing Nagano Co.
Established NTN Driveshaft Inc. (Columbus, IN — CVJ facility)
Renamed parent company NTN Corporation.
Bearing hub unit production began at Elgin, IL, facility.</p> <p>1990 Built new building for R&D at Kuwana Plant.
NTN USA Corporation founded as headquarters in the U.S.A.</p> <p>1991 NBCA and NTN USA Corp. occupied new Head Office in Mt. Prospect, IL.
NBCA Eastern Region occupied new offices, training center and warehouse in Exton, PA.</p> <p>1994 Obtained ISO9002 certification (Kuwana Plant).
Established a distribution center in Singapore.</p> <p>1996 Bought the ball bearing division of American firm Federal-Mogul Corporation (U.S.A.), NTN-BCA established.
Achieved 200-million target for domestic production of constant velocity joints</p> <p>1997 Nagano Plant and 4 engineering departments obtained ISO9001/QS-9000 certification for their quality systems
Established NTN do Brazil Ltda.</p> <p>1998 Established NTN Manufacturing (Thailand) Co., Ltd.
Iwata area NTN enterprises obtained ISO14001 certification</p> | <p>Established NTN Transmission Europe for CVJ production through a joint corporation with Renault of France.</p> <p>1999 All plants and R&D Centers in Japan obtained ISO14001 certification by a multi-site qualification procedure</p> <p>2000 NTN Group completed full certification for the ISO9000 series</p> <p>2002 In a joint venture, established SHANGHAI NTN CORPORATION in China for the manufacture of CVJ cassettes and other products. In a joint venture with Nidec Corporation of Japan, established NTN-NIDEC (ZHEJIANG) CORPORATION for the manufacture of FDB units in China.
In a joint venture with Taiwan Yulong Group Corporation, established GUANGZHOU NTN-YULON DRIVETRAIN CO., LTD. for the manufacture of C.V. Joint Units in Guang Zhou, China.</p> <p>2003 In the U.S.A. established NTK Precision Axle Corporation and Asahi Forge of America Corporation, joint ventures for production of constant velocity joint components. In China established Beijing NTN-Seohan Driveshaft Co., Ltd., a joint venture with Korea Flange Co., Ltd. for constant velocity joint production</p> |
|---|---|



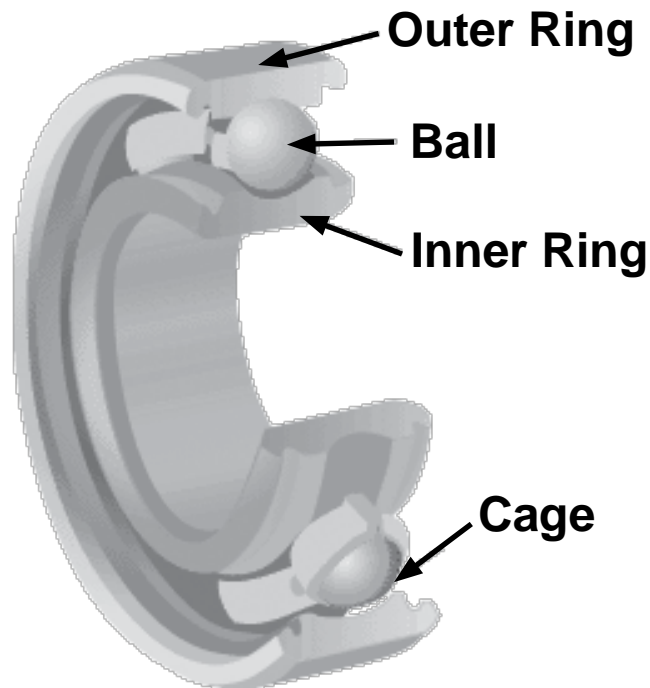

CLASSIFICATION OF ANTI-FRICTION BEARINGS

Most rolling bearings consist of bearing rings (an inner ring and an outer ring), rolling elements and a rolling element retainer (cage). The retainer separates the rolling elements at regular intervals, holds them in place within the inner and outer raceways, and allows them to rotate freely.

Rolling bearings fall into two main classifications: ball bearings and roller bearings. Balls geometrically contact the raceway surfaces of the inner and outer rings at “points,” while the contact surface of rollers is a “line” contact. Rollers come in four basic geometric styles: cylindrical, needle,

tapered and spherical. Rolling bearings can further be classified according to the direction in which the load is applied: radial, thrust, or a combination of both.

While the rolling elements and the bearing rings take any load applied to the bearings (at the contact point between the rolling elements and raceway surfaces), the retainer takes no direct load. It only serves to hold the rolling elements at equal distances from each other, forcing the rolling elements to enter the load zones and prevent them from falling out.

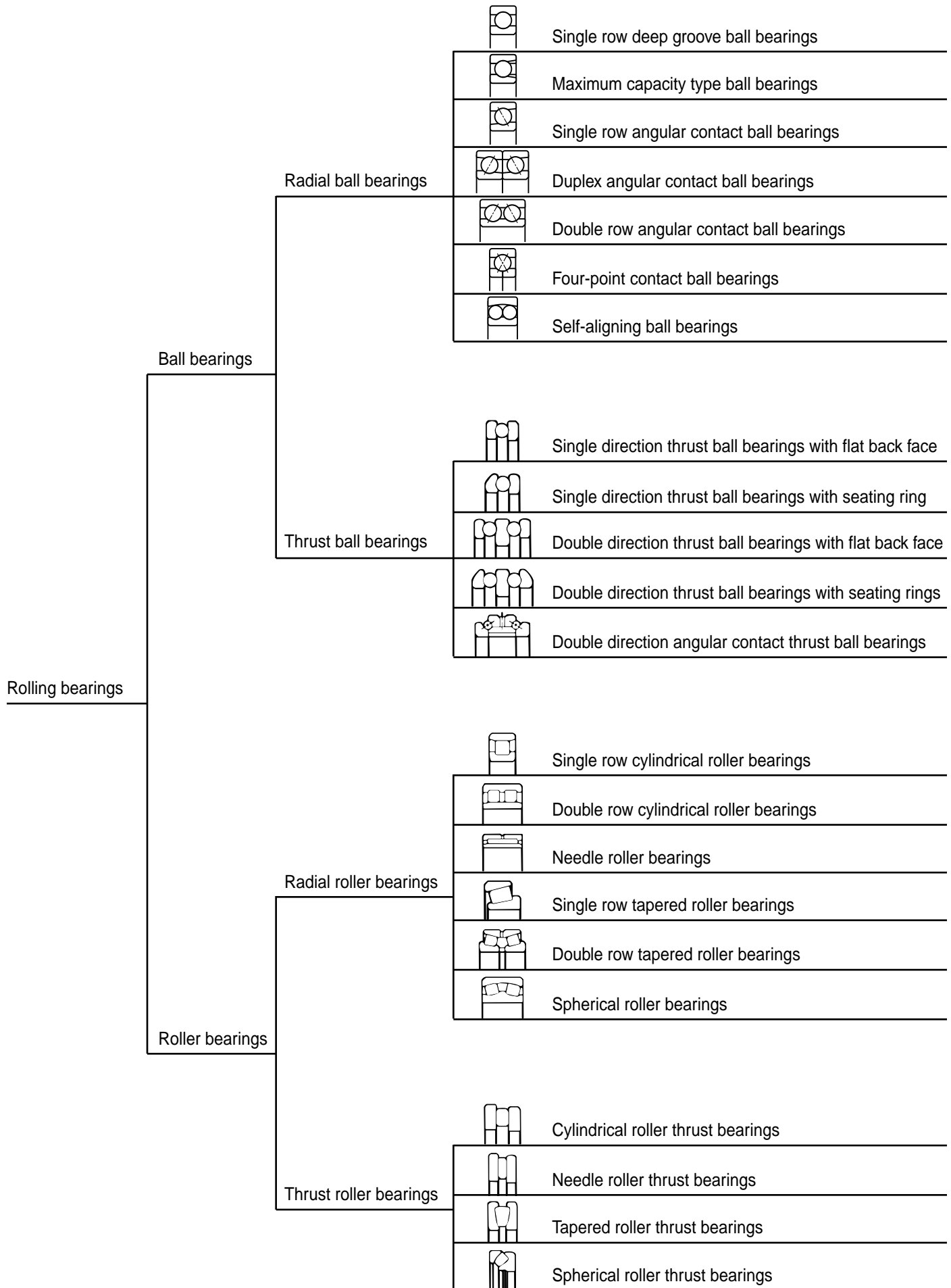



DESIGN AND CHARACTERISTICS OF BALL AND ROLLER BEARINGS

SINGLE ROW RADIAL BALL BEARINGS are the most widely used bearings and utilize an uninterrupted raceway, which makes these bearings suitable for radial loads, or a combination of thrust and radial loads. This design permits precision tolerances even at high speed operation.

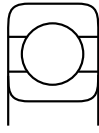

The cage in this bearing is pressed steel. For high speed bearings, machined brass cages are available. Bearings with locating snap rings are also available.

PRELUBRICATED BEARINGS have integral seals, or shields, which are packed with long-life grease. In many applications, these bearings may be used without supplementary seals, closures, or protective devices. This design offers the lowest possible manufacturing cost to the consumer.

The boundary dimension of this type is the same as the corresponding bearings without the seals or shields.

SHIELDED BALL BEARINGS are protected on one, or both sides (suffixes Z and ZZ, respectively) by metal shields fastened to the outer ring. This close clearance labyrinth seal retains the lubricant and prevents the entrance of foreign matter.



SEALED BALL BEARINGS incorporate steel reinforced rubber seals securely fastened to a groove on the outer ring. Contact with the inner ring is by sealing lip (Contact Suffix LLU). Or, non-contact with the inner ring is by labyrinth seal (Non-contact Suffix LLB) to provide positive sealing at all times.

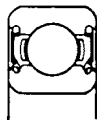

SINGLE ROW ANGULAR CONTACT BALL BEARINGS feature raceways with high and low shoulders. These opposing raceways are designed to carry thrust load in one direction.

These bearings may be preloaded at the factory so that the correct preload will develop within the bearing.

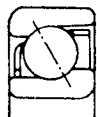

The bearings in this series are assembled with a specific internal clearance so that they will have a speci-

fied contact angle under load. The standard contact load used by NTN is 30°; bearings made to a 40° contact angle carry the suffix B.

For high speed grinding spindles, the 7000C, 7200C and the 7300C series are available. They are high accuracy bearings with a 15° contact angle, and phenolic resin cages for high speed operations.

DOUBLE ROW ANGULAR CONTACT BALL BEARINGS have an inner and outer ring with a double raceway. The two rows are so related that the contact angle is similar to a pair of back-to-back

single row bearings. The 5200 and 5300 series offer continuous races and can carry thrust loads in either direction. Since the 3200 and 3300 series have filling slots, it is necessary to mount them with the thrust load acting against the unnotched face of the rings.

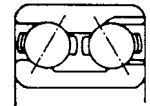

DOUBLE ROW SELF-ALIGNING BEARINGS utilize an inner ring with two rows of balls in two deep raceways, and an outer ring with a single spherical raceway. In this way, the inner and outer rings can be misaligned relative to each other. The resulting effect is a comparatively large angle imposing moment loads upon the balls.

The boundary dimensions of the 1200 and 1300 series are the same as the 6200 and 6300 single row deep groove bearings.

CYLINDRICAL ROLLER BEARINGS have rollers which are essentially cylindrical in shape. This provides a modified line contact with the cylindrical inner and outer ring raceways, while the rollers are guided by ground ribs on either the inner or outer ring.

The cylindrical shape allows the inner ring to have axial movement relative to the outer ring (except the NH type). This is especially important when accommodating thermal expansion when both rings must be press fitted.

In this series, the NJ, NF and NH types can carry light or intermittent thrust loads.

The NN3000 and NN3000K series are available in high precision tolerances and are well suited for use in machine tool spindles.

TAPERED ROLLER BEARINGS utilize conical rollers and raceways arranged so that the rollers and raceways meet at a common apex. The rollers are guided by contact between the large end of the roller and a rib on the inner ring. This provides high capacity for radial and single thrust loads.

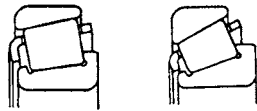

SPHERICAL ROLLER BEARINGS have two rows of rollers in separate raceways which allows the bearing to compensate for angular thrust errors. They have large radial and thrust load capacity for heavy shock and impact loads, making them suitable for heavy industrial equipment.

DUPLEX BEARINGS use a set of two on a common shaft with the inner and outer rings clamped solidly together. They are used to gain axial shaft control, rigidity and extra capacity.

There are three fundamental combinations in duplex bearings: face-to-face (DF), back-to-back (DB), and tandem (DT).

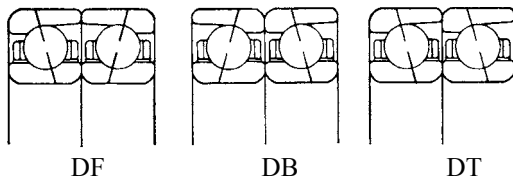

SINGLE DIRECTION THRUST BEARINGS consist of two washers having ball grooves ground into their adjacent faces with balls and cages mounted between these grooves. They are normally equipped with either pressed or machined cages and are suitable for carrying thrust loads at moderate speeds.

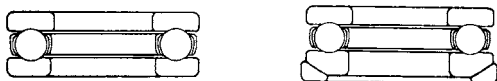

DOUBLE DIRECTION ANGULAR CONTACT THRUST BALL BEARINGS are back-to-back duplex bearings with a larger contact angle than that of normal angular contact ball bearings.

These bearings are primarily designed as thrust bearings for machine tools. They utilize machined brass cages.

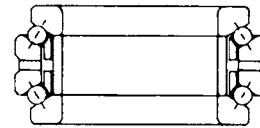

SPHERICAL ROLLER THRUST BEARINGS are similar to double row spherical roller bearings, but have a greater contact angle. They are guided by ground flanges on the inner ring and operate against the spherical raceway in the outer ring. The contact angle is approximately 45°. Machined cages are normally used, and oil lubrication is recommended.

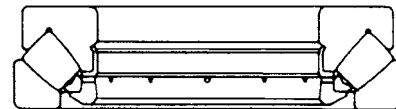

BEARING UNITS consist of a ball or roller bearing installed within a housing. The housings are most commonly made of cast iron but may also be made of other metals or nonmetallic materials. The housing provides rigidity and secure positioning for the bearing within the application. It also simplifies the task of replacing the bearing as the housing and bearing can be replaced as a complete unit.

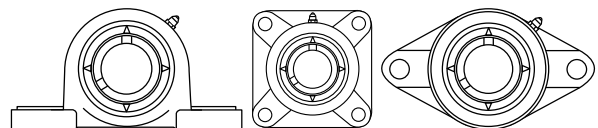

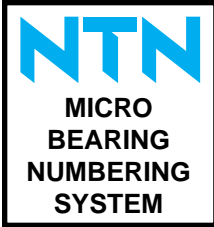

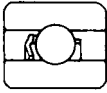
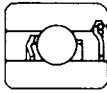
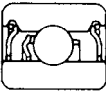
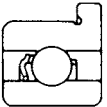
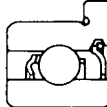
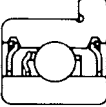
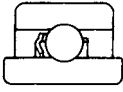
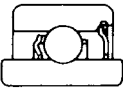
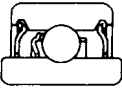
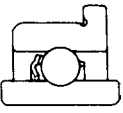
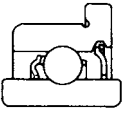
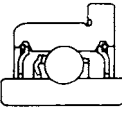
Open Type	Single Shield Type	Double Shield Type	Open Type	Flanged Outer Ring Single Shield Type	Double Shield Type
 67 68 69 60 62 63 R(A)	 W(A)67ZA W68Z(A) (W)69Z(A) (W)60Z(A) 62Z 63Z R(A)-Z(A)	 W(A)67ZZA W68ZZ(A) (W)69ZZ(A) (W)60ZZ(A) 62ZZ 63ZZ R(A)-ZZ(A)	 FL67 FL68 FL69 FL60 FL62 FL63 FLR(A)	 FL(A)W(A)67ZA FLW68Z(A) FL(W)69Z(A) FL(W)60Z(A) FL62Z FL63Z FLR(A)-Z(A)	 FL(A)W(A)67ZZA FLW68ZZ(A) FL(W)69ZZ(A) FL(W)60ZZ(A) FL62ZZ FL63ZZ FLR(A)-ZZ(A)
 RW	 R(A)W-ZA	 R(A)W-ZZA	 FLRW	 FLR(A)W-ZA	 FLR(A)W-ZZA

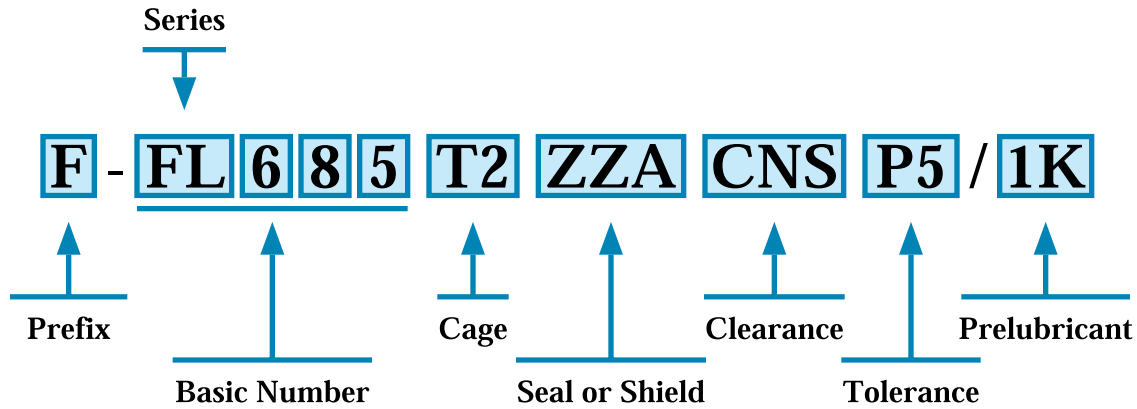

1. PREFIX

No Symbol: High carbon chrome bearing steel (equivalent to AISI E52100)
 F: Martensitic stainless steel (equivalent to AISI 440C)

2. SERIES

67, 68: Metric series
 69, 60: Metric series
 62, 63: Metric series
 R: Inch series
 W: Wider than standard width (sealed type)
 WA: Non-standard sizes
 RA: Wider than standard width of inch series (open and sealed types)
 FL: Flanged outer ring
 FLA: Flanged outer ring, provided non-standard flange dimensions

3. CAGE

No Symbol: Pressed steel cage
 J1: Pressed stainless steel cage
 T1: Phenolic resin cage
 T2: Nylon cage

4. SEAL OR SHIELD

No symbol: Open Type
 Z, ZZ: Steel shield(s)
 ZA, ZZA: Removable steel shield(s)
 ZA1, ZZA1: Removable stainless steel shield(s)
 Z1, ZZ1: Stainless steel shield(s)
 LB, LLB: Non-contact type rubber seal(s)
 LU, LLU: Contact type rubber seal(s)

5. INTERNAL CLEARANCE

No Symbol: Normal clearance
 C2: Clearance less than normal
 C3: Clearance greater than normal
 C4: Clearance greater than C3
 C2S: Low group of C2 clearance
 CNS: Low group of normal clearance
 CNM: Medium group of normal clearance
 CNL: High group of normal clearance
 C3S: Low group of C3 clearance
 C3M: Medium group of C3 clearance
 C3L: High group of C3

6. TOLERANCE

No Symbol: ISO class 0 (equivalent to ABEC 1)
 P6: ISO class 6 (equivalent to ABEC 3)
 P5: ISO class 5 (equivalent to ABEC 5)
 P4: ISO class 4 (equivalent to ABEC 7)
 P2: ISO class 2 (equivalent to ABEC 9)
 P5A: ISO class 5A
 P4A: ISO class 4A
 PS5: NTN PS class 5
 PS4: NTN PS class 4
 PX1: Special tolerance

7. PRELUBRICANT

1K: Kyodo Yushi Multemp PS No. 2
 2AS: Shell Alvania 2
 1E: Exxon Andok C
 6K: Klüber Isoflex Super LDS18
 5C: Chevron SRI2
 5K: Kyodo Yushi Multemp SRL
 1W: Anderson Oil Winsor Lube L245X (oil)
 L627: Exxon Polyrex EM

10. SPECIAL SPECIFICATION

V1...Vn

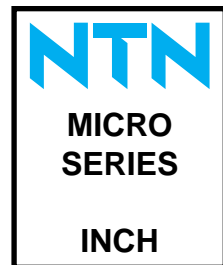

Units: INCHES

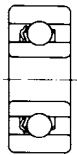
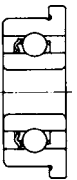
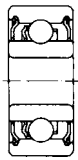
MICRO BEARING (INCH SERIES)																	
OPEN TYPE					DOUBLE SHIELD TYPE												
					 Flanged Outer Ring					 Flanged Outer Ring							
Bearing No.	Boundary Dimensions				Bearing No. Flange Type	Boundary Dimensions			Bearing No.	Boundary Dimensions			Flange Width	Basic Load Ratings (lbs)		Limiting Speeds (RPM)	
	Bore	O.D.	Width	Min. Chamfer		Flange O.D.	Flange Width			Width	Bearing No. Flange Type w/Shields	OD		C Dynamic	Co Static	Grease	Oil
R01	0.0400	0.1250	0.0469	0.003	—	—	—	—	—	—	—	—	—	22	6	110,000	130,000
R0	0.0469	0.1562	0.0625	0.003	FLR0	0.203	0.013	RA0ZZA	0.0937	FLRA0ZZA	0.203	0.031	36	10	93,000	110,000	
R1	0.0550	0.1875	0.0781	0.003	FLR1	0.234	0.023	RA1ZZA	0.1094	FLRA1ZZA	0.234	0.031	42	13	81,000	95,000	
R1-4	0.0781	0.2500	0.0937	0.003	FLR1-4	0.296	0.023	RA1-4ZZA	0.1406	FLRA1-4ZZA	0.296	0.031	63	20	67,000	79,000	
R133	0.0937	0.1875	0.0625	0.003	FLR133	0.234	0.018	RA133ZZA	0.0937	FLRA133ZZA	0.234	0.031	28	9.5	73,000	85,000	
R1-5	0.0937	0.3125	0.1094	0.005	FLR1-5	0.359	0.023	RA1-5ZZA	0.1406	FLRA1-5ZZA	0.359	0.031	96	34	56,000	66,000	
R144	0.1250	0.2500	0.0937	0.003	FLR144	0.296	0.023	RA144ZZA	0.1094	FLRA144ZZA	0.296	0.031	64	22	59,000	70,000	
R2-5	0.1250	0.3125	0.1094	0.003	FLR2-5	0.359	0.023	RA2-5ZZA	0.1406	FLRA2-5ZZA	0.359	0.031	126	40	54,000	63,000	
R2-6	0.1250	0.3750	0.1094	0.005	—	—	—	RA2-6ZZA	0.1406	—	—	—	144	50	49,000	58,000	
R2	0.1250	0.3750	0.1562	0.012	FLR2	0.440	0.030	R2ZZA	0.1562	FLR2ZZA	0.440	0.030	144	50	49,000	58,000	
RA2	0.1250	0.5000	0.1719	0.012	—	—	—	RA2ZZ	0.1719	—	—	—	258	89	43,000	51,000	
R155	0.1562	0.3125	0.1094	0.003	FLR155	0.359	0.023	RA155ZZA	0.1250	FLRA155ZZA	0.359	0.036	76	30	51,000	60,000	
R156	0.1875	0.3125	0.1094	0.003	FLR156	0.359	0.023	RA156ZZA	0.1250	FLRA156ZZA	0.359	0.036	89	32	49,000	58,000	
R166	0.1875	0.3750	0.1250	0.003	FLR166	0.422	0.023	R166ZZA	0.1250	FLRA166ZZA	0.422	0.031	160	60	46,000	55,000	
R3	0.1875	0.5000	0.1562	0.012	—	—	—	—	0.1875	—	—	—	295	110	41,000	48,000	
RA3	0.1875	0.5000	0.1960	0.012	FLRA3	0.565	0.042	RA3ZZ	0.1960	FLRA3ZZ	0.565	0.042	295	110	41,000	48,000	
R168	0.2500	0.3750	0.1250	0.003	FLR168	0.422	0.023	R168ZZA	0.1250	FLRA168ZZA	0.422	0.036	60	31	43,000	51,000	
R188	0.2500	0.5000	0.1250	0.005	FLR188	0.547	0.023	RA188ZZA	0.1875	FLRA188ZZA	0.547	0.045	186	84	39,000	46,000	
R4	0.2500	0.6250	0.1960	0.012	FLR4	0.690	0.042	R4ZZ	0.1960	FLR4ZZ	0.690	0.042	335	136	36,000	43,000	
R6	0.3750	0.8750	0.2812	0.016	FLR6	0.989	0.062	R6ZZ	0.2812	FLR6ZZ	0.989	0.062	526	199	31,000	37,000	

Bearing numbers listed above are for bearings made of high carbon chrome bearing steel; bearings made of stainless steel (equivalent to AISI 440 C) are also available upon request, for which "F" should be prefixed to the bearing numbers.

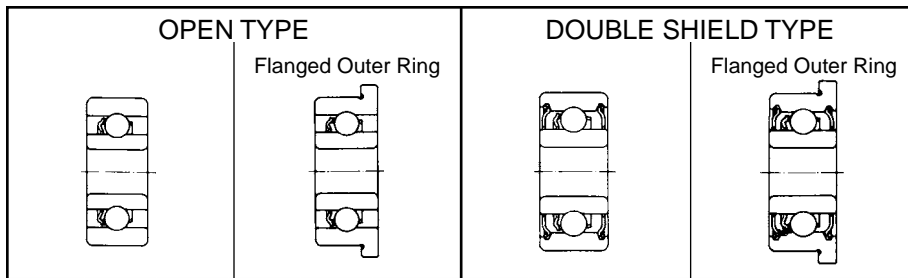

Units: Millimeters

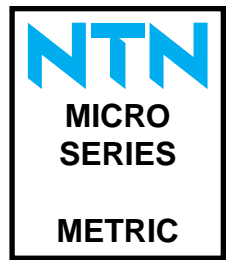

MICRO BEARING (METRIC SERIES)

Bearing No.	Boundary Dimensions				Bearing No.	Flange Dimensions		Bearing No.	Width	Bearing No.	Flange Dimensions		Limiting Speed (RPM)		Basic Load Ratings (lbs)	
	Bore	O.D.	Width	Min. Chamfer		O.D.	Width				O.D.	Width	Grease	Oil	Dynamic C	Static C ₀
68/1.5	1.5	4	1.2	0.15	FL68/1.5	5.0	0.4	W68/1.5ZZA	2.0	FLW68/1.5ZZA	5.0	0.60	88,000	100,000	23	6
69/1.5A	1.5	5	2.0	0.15	FL69/1.5	6.5	0.6	W69/1.5ZZA	2.6	FLW69/1.5ZZA	6.5	0.80	79,000	93,000	53	15
60/1.5	1.5	6	2.5	0.15	FL60/1.5	7.5	0.6	W60/1.5ZZA	3.0	FLW60/1.5ZZA	7.5	0.80	71,000	84,000	62	19
672	2.0	4	1.2	0.05	—	—	—	W672ZZA	2.0	—	—	—	83,000	98,000	23	8.5
682	2.0	5	1.5	0.08	FL682	6.1	0.5	W682ZZA	2.3	FLW682ZZA	6.1	0.60	74,000	87,000	38	11
692	2.0	6	2.3	0.15	FL692	7.5	0.6	W692ZZA	3.0	FLW692ZZA	7.5	0.80	67,000	79,000	63	20
602	2.0	7	2.8	0.15	FL602	8.5	0.7	W602ZZA	3.5	FLW602ZZA	8.5	0.90	62,000	73,000	86	28
67/2.5	2.5	5	1.5	0.08	—	—	—	W67/2.5ZZA	2.3	—	—	—	70,000	82,000	34	13
68/2.5	2.5	6	1.8	0.08	FL68/2.5	7.1	0.5	W68/2.5ZZA	2.6	FLW68/2.5ZZA	7.1	0.80	35,000	76,000	47	16
69/2.5	2.5	7	2.5	0.15	FL69/2.5	8.5	0.7	W69/2.5ZZA	3.5	FLW69/2.5ZZA	8.5	0.90	59,000	70,000	64	22
60/2.5	2.5	8	2.8	0.15	FL60/2.5	9.5	0.7	W60/2.5ZZA	4.0	FLW60/2.5ZZA	9.5	0.90	56,000	66,000	123	39
673	3.0	6	2.0	0.08	FL673	7.2	0.6	WA673ZZA	2.5	FLWA673ZZA	7.2	0.60	60,000	71,000	54	21
683	3.0	7	2.0	0.1	FL683	8.1	0.5	W683ZZA	3.0	FLW683ZZA	8.1	0.80	58,000	68,000	87	29
693	3.0	8	3.0	0.15	FL693	9.5	0.7	W693ZZA	4.0	FLW693ZZA	9.5	0.90	54,000	63,000	126	40
603	3.0	9	3.0	0.15	FL603	10.5	0.7	W603ZZA	5.0	FLW603ZZA	10.5	1.00	50,000	59,000	142	49
623	3.0	10	4.0	0.15	FL623	11.5	1.0	623ZZA	4.0	FL623ZZA	11.5	1.00	50,000	58,000	144	50
694	4.0	11	4.0	0.15	FL694	12.5	1.0	694ZZA	4.0	FL694ZZA	12.5	1.00	45,000	52,000	161	62
604	4.0	12	4.0	0.20	FL604	13.5	1.0	604ZZ	4.0	FL604ZZ	13.5	1.00	43,000	51,000	218	80
624	4.0	13	5.0	0.20	FL624	15.0	1.0	624ZZ	5.0	FL624ZZ	15.0	1.00	42,000	49,000	295	110
634	4.0	16	5.0	0.30	—	—	—	634ZZ	5.0	—	—	—	37,000	44,000	395	153
675	5.0	8	2.0	0.08	FL675	9.2	0.6	WA675ZZA	2.5	FLWA675ZZA	9.2	0.60	49,000	57,000	66	32
685	5.0	11	3.0	0.15	FL685	12.5	0.8	W685ZZA	5.0	FLW685ZZA	12.5	1.00	43,000	51,000	161	63
695	5.0	13	4.0	0.20	FL695	15.0	1.0	695ZZA	4.0	FL695ZZA	15.0	1.00	40,000	47,000	242	97
605	5.0	14	5.0	0.20	FL605	16.0	1.0	605ZZ	5.0	FL605ZZ	16.0	1.00	39,000	46,000	299	114
625	5.0	16	5.0	0.30	FL625	18.0	1.0	625ZZ	5.0	FL625ZZ	18.0	1.00	37,000	44,000	395	153
635	5.0	19	6.0	0.30	—	—	—	635ZZ	6.0	—	—	—	34,000	40,000	525	199
686	6.0	13	3.5	0.15	FL686	15.0	1.0	W686ZZA	5.0	FLW686ZZA	15.0	1.10	39,000	46,000	243	99
696	6.0	15	5.0	0.20	FL696	17.0	1.2	696ZZ	5.0	FL696ZZ	17.0	1.20	37,000	44,000	305	119
606	6.0	17	6.0	0.30	FL606	19.0	1.2	606ZZ	6.0	FL606ZZ	19.0	1.20	35,000	42,000	495	195
626	6.0	19	6.0	0.30	FL626	22.0	1.5	626ZZ	6.0	FL626ZZ	22.0	1.50	34,000	40,000	525	199
677	7.0	11	2.5	0.10	FL677	12.2	0.6	WA677ZZA	3.0	FLWA677ZZA	12.2	0.60	40,000	47,000	124	60
687	7.0	14	3.5	0.15	FL687	16.0	1.0	W687ZZA	5.0	FLW687ZZA	16.0	1.10	37,000	44,000	264	115
697	7.0	17	5.0	0.30	FL697	19.0	1.2	697ZZ	5.0	FL697ZZ	19.0	1.20	35,000	41,000	360	160
607	7.0	19	6.0	0.30	—	—	—	607ZZ	6.0	—	—	—	34,000	40,000	505	205
627	7.0	22	7.0	0.30	—	—	—	627ZZ	7.0	—	—	—	32,000	37,000	750	315
698	8.0	19	6.0	0.30	FL698	22.0	1.5	698ZZ	6.0	FL698ZZ	22.0	1.50	33,000	39,000	445	194
608	8.0	22	7.0	0.30	FL608	25.0	1.5	608ZZ	7.0	FL608ZZ	25.0	1.50	32,000	37,000	750	315
628	8.0	24	8.0	0.30	—	—	—	628ZZ	8.0	—	—	—	31,000	36,000	900	355
679	9.0	14	3.0	0.10	—	—	—	W679ZZA	4.5	—	—	—	36,000	42,000	207	105
689	9.0	17	4.0	0.20	FL689	19.0	1.0	W689ZZ	5.0	FLW689ZZ	19.0	1.10	33,000	39,000	390	184
699	9.0	20	6.0	0.30	—	—	—	699ZZ	6.0	—	—	—	32,000	38,000	560	245
609	9.0	24	7.0	0.30	—	—	—	609ZZ	7.0	—	—	—	31,000	36,000	765	325
629	9.0	26	8.0	0.60	—	—	—	629ZZ	8.0	—	—	—	30,000	35,000	1030	440

Bearing numbers listed above are for bearings made of high carbon chrome bearing steel; bearings made of stainless steel (equivalent to AISI 440 C) are also available upon request, for which "F" should be prefixed to the bearing numbers.

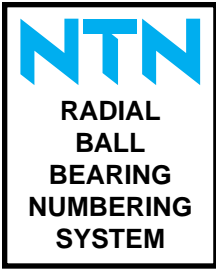

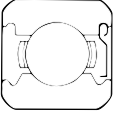
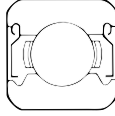
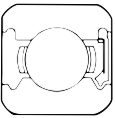
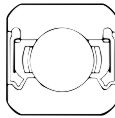
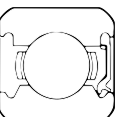
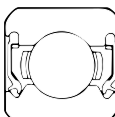
SEAL STRUCTURE AND TYPE DESIGNATION	FEATURES
  Z ZZ	<p>The sealed V-slot around the inner ring creates an air and/or grease pocket which increases the labyrinth effect.</p> <p>This is a non-contact, low-friction torque type bearing assembly, which can be used effectively for general protection.</p>
  LB LLB	<p>Both sides of the seal edge have a circular concaved surface which creates several narrow wide gaps along the V-shaped groove of the inner ring's sealed surface. The unique design ensures a perfect labyrinth effect.</p> <p>This non-contact, low friction bearing assembly requires very little torque and is highly resistant to dust build-up.</p>
  LU LLU	<p>The seal edge forms a double-lip. The inner lip touches the V-slot side of the inner ring's seal surface. There is a slight gap between the inner ring and the outer lip which produces the labyrinth effect. Even if friction causes the inner lip to wear, the outer lip constricts around the inner ring to compensate, and thus constantly preserving the perfect sealing effect.</p> <p>Due to the fact that it is a contact type seal bearing, the torque will be a little greater but the seal will provide the optimum protection from dust penetration.</p>

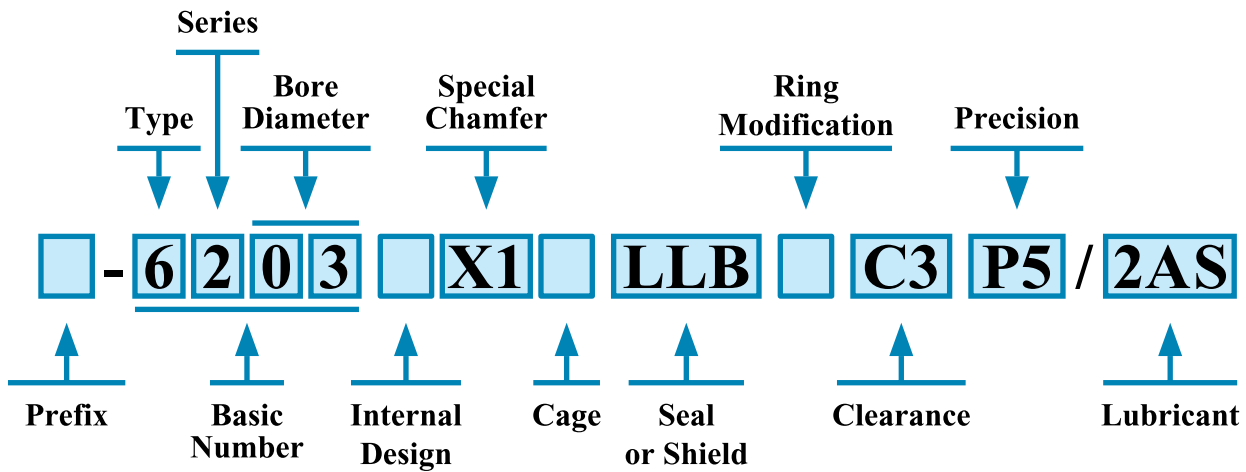

1. PREFIX

- TS2: Heat stabilization for up to 320° F (160° C)
- TS3: Heat stabilization for up to 390° F (200° C)
- TS4: Heat stabilization for up to 480° F (250° C)

2. TYPE

- 6: Single row deep groove ball bearings
- 8, WC8: Single row deep groove ball bearings
- BL: Maximum capacity
- DE & DF: Special double row ball bearings
- SC & SX: Special single row ball bearings
- R: Inch series
- TMB: Thermal mechanical bearing

3. INTERNAL DESIGN

- A: Internal redesign, from A onward
- U: Universal seal groove for open bearings

4. CHAMFER

- Xn: Special chamfer, from 1 onward (X1, X2 ...)

5. CAGE

- No Symbol: Pressed steel cage
- J: Pressed steel cage
- T1: Phenolic cage
- T2: Nylon cage
- L1: Machined brass cage

6. SEAL OR SHIELD

- No Symbol: Open Type
- LB, LLB: Non-contact rubber seal
- LU, LLU: Double-lip contact rubber seal
- LH, LLH: Light contact rubber seal
- LUA, LLUA: Polyacrylic rubber seal
- LUA1, LLUA1: Fluorocarbon rubber seal
- Z, ZZ: Shield
- Z1, ZZ1: Stainless steel shield
- ZA, ZZA: Removable shield

7. RING MODIFICATION

- N: Snap ring groove on outer ring, but without snap ring
- NR: Snap ring groove on outer ring, snap ring included
- /X.XX: Special bore, XX.XX in mm; Ex. 5/16" bore, /7.938
- /XX.X: Special O.D., size XX.X in mm

8. INTERNAL CLEARANCE

- C1: Radial clearance less than C2
- C2: Radial clearance less than normal
- C3: Radial clearance greater than normal
- C4: Radial clearance greater than C3
- C5: Radial clearance greater than C4
- CSXX: Special radial clearance; XX is mean value in 0.001 mm units

9. TOLERANCE

- P6: ISO class 6 (equivalent to ABEC 3)
- P5: ISO class 5 (equivalent to ABEC 5)
- P4: ISO class 4 (equivalent to ABEC 7)
- PXn: Special tolerance, from 1 onward (PX1, PX2 ...)
- Vn: Special requirement, from 1 onward (V1, V2 ...)

10. PRELUBRICANT (Typical)

- 1E: Exxon Andok C grease
- 1W: Anderson Oil Winsor Lube L-245X, MIL-L-6085A
- 2AS: Shell Alvania #2 grease, MIL-G-18709A
- 2E: Exxon Unirex N3
- 3AS: Shell Oil Alvania #3 grease
- 5C: Chevron SRI #2 grease, MIL-G-3545C
- 5K: Kyodo Yushi Multemp SRL
- 5S: Shell Aeroshell #7 grease, MIL-G-23827A
- 9B: Mobil 28, MIL-G-81322
- L627: Exxon Polyrex EM

SINGLE ROW RADIAL BALL BEARINGS

Units: INCHES



Bearing No.	Bore	O.D.	Width	Fillet Radius	Basic Load Ratings (lbs)		Weight (lbs)	Limiting Speed (rpm)	
	d	D	B	(min.) r	Dynamic C	Static C ₀	Open Type	Grease	Oil
RA3	.1875	.5000	.1960	0.012	295	110	.006	41,000	48,000
R4	.2500	.6250	.1960	0.012	335	139	.010	36,000	43,000
RA4	.2500	.7500	.2812	0.016	525	199	.017	34,000	40,000
R6	.3750	.8750	.2812	0.016	745	315	.029	31,000	37,000
R8	.5000	1.1250	.3125	0.016	1,150	540	.040	26,000	30,000
R10	.6250	1.3750	.3437	0.031	1,350	735	.067	20,000	24,000
R12	.7500	1.6250	.4375	0.031	1,780	1,000	.100	18,000	21,000
R14	.8750	1.8750	.5000	0.031	2,270	1,300	.159	15,000	18,000
R16	1.0000	2.0000	.5000	0.031	2,260	1,340	.178	14,000	16,000
R18	1.1250	2.1250	.5000	0.031	2,970	1,860	.194	13,000	15,000
R20	1.2500	2.2500	.5000	0.031	2,650	1,810	.200	12,000	14,000

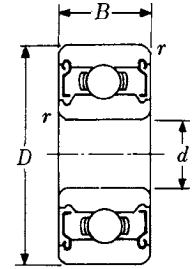

Double Shielded
ZZ

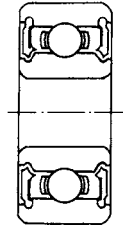

Double Sealed
LLB
(Non-contact Type)

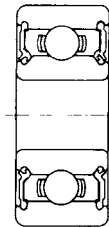

Double Sealed
LLU
(Contact Type)



Units: INCHES
Millimeters

SINGLE ROW RADIAL BALL BEARINGS

Bearing No.	Bore d	O.D. D	Width B	Fillet Radius r	Basic Load Ratings (lbs)		Weight (lbs)	Limiting Speed		
					Dynamic C	Static C ₀		Grease	Oil	LLU
605	.1969 5	.5512 14	.1969 5	.008 .2	299	114	.008	39,000	46,000	—
606	.2362 6	.6693 17	.2362 6	.012 .3	495	195	.013	35,000	42,000	—
607	.2756 7	.7480 19	.2362 6	.012 .3	505	205	.018	34,000	40,000	28,000
608	.3150 8	.8661 22	.2756 7	.012 .3	750	315	.026	32,000	37,000	23,000
609	.3543 9	.9449 24	.2756 7	.012 .3	765	325	.031	31,000	36,000	22,000
623	.1181 3	.3937 10	.1575 4	.006 .15	144	50	.004	50,000	58,000	—
624	.1575 4	.5118 13	.1969 5	.008 .2	295	110	.007	42,000	49,000	—
625	.1969 5	.6299 16	.1969 5	.012 .3	395	153	.011	37,000	44,000	—
626	.2362 6	.7480 19	.2362 6	.012 .3	525	199	.018	34,000	40,000	30,000
627	.2756 7	.8661 22	.2756 7	.012 .3	750	315	.029	32,000	37,000	23,000
628	.3150 8	.9449 24	.3150 8	.012 .6	900	355	.037	31,000	36,000	24,000
629	.3543 9	1.0236 26	.3150 8	.024 .6	1,030	440	.044	30,000	35,000	21,000
634	.1575 4	.6299 16	.1969 5	.012 .3	395	153	.011	37,000	44,000	—
635	.1969 5	.7480 19	.2362 6	.012 .3	525	199	.018	34,000	40,000	30,000

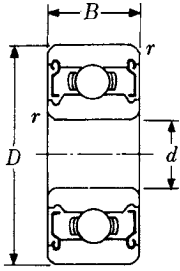

Double Shielded
ZZ

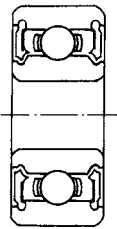

Double Sealed
LLB
(Non-contact Type)

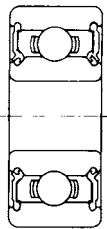

Double Sealed
LLU
(Contact Type)

SINGLE ROW RADIAL BALL BEARINGS

Units: **INCHES**
Millimeters



Bearing No.	Bore	O.D.	Width	Fillet Radius	Basic Load Ratings (lbs)		Weight (lbs)	Limiting Speed (RPM)	
	d	D	B	r	Dynamic C	Static C ₀		Grease	Oil
6900	.3937 10	.8661 22	.2362 6	.012 .3	605	285	.020	30,000	36,000
6901	.4724 12	.9449 24	.2362 6	.012 .3	650	330	.024	27,000	32,000
6902B	.5906 15	1.1024 28	.2756 7	.012 .3	920	460	.035	24,000	28,000
6903	.6693 17	1.1811 30	.2756 7	.012 .3	1,050	580	.040	22,000	26,000
6904	.7874 20	1.4567 37	.3543 9	.012 .3	1,430	825	.079	19,000	23,000
6905	.9843 25	1.6535 42	.3543 9	.012 .3	1,580	1,020	.093	16,000	19,000
6906	1.1811 30	1.8504 47	.3543 9	.012 .3	1,630	1,130	.106	14,000	17,000
6907A	1.3780 35	2.1654 55	.3937 10	.024 .6	2,510	1,670	.163	12,000	15,000
6908A	1.5748 40	2.4409 62	.4724 12	.024 .6	3,250	2,300	.243	11,000	13,000
6909A	1.7717 45	2.6772 68	.4724 12	.024 .6	3,400	2,530	.282	9,800	12,000
6910B	1.9685 50	2.8346 72	.4724 12	.024 .6	3,500	2,750	.291	8,900	11,000
6911	2.1654 55	3.1496 80	.5118 13	.039 1.0	3,600	2,980	.397	8,200	9,600
6912	2.3622 60	3.3465 85	.5118 13	.039 1.0	3,700	3,200	.425	7,600	8,900
6913	2.5591 65	3.5433 90	.5118 13	.039 1.0	3,900	3,600	.454	7,000	8,200
6914	2.7559 70	3.9370 100	.6299 16	.039 1.0	5,350	4,750	.736	6,500	7,700
6915	2.9528 75	4.1339 105	.6299 16	.039 1.0	5,500	5,100	.778	6,100	7,200
6916	3.1496 80	4.3307 110	.6299 16	.039 1.0	5,600	5,400	.822	5,700	6,700
6917	3.3465 85	4.7244 120	.7087 18	.043 1.1	7,200	6,650	1.18	5,400	6,300
6918	3.5433 90	4.9213 125	.7087 18	.043 1.1	7,400	7,100	1.22	5,100	6,000
6919	3.7402 95	5.1181 130	.7087 18	.043 1.1	7,550	7,550	1.28	4,800	5,700
6920	3.9370 100	5.5118 140	.7874 20	.043 1.1	9,250	8,900	1.73	4,500	5,300
6921	4.1339 105	5.7087 145	.7874 20	.043 1.1	9,550	9,450	1.80	4,300	5,100
6922	4.3307 110	5.9055 150	.7874 20	.043 1.1	9,800	10,000	1.87	4,100	4,800
6924	4.7244 120	6.4961 165	.8661 22	.043 1.1	11,900	12,200	2.54	3,800	4,400

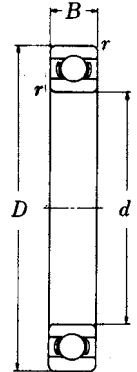



Units: INCHES
Millimeters

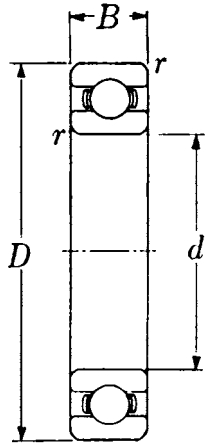

Open Type
60

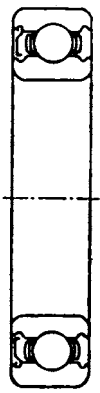

Single
Shielded
60Z



Double
Shielded
60ZZ

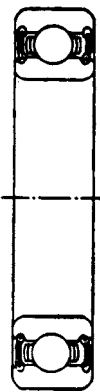

Double
Sealed
60LLU

(Contact Type)



Double
Sealed
60LLB

(Non-Contact Type)

SINGLE ROW RADIAL BALL BEARINGS

Bearing No.	Bore d	O.D. D	Width B	Fillet Radii		Basic Load Ratings (lbs)		Weight (lbs)
				r	r ₁	Dynamic C	Static C ₀	
6000	.3937 10	1.0236 26	.3150 8	.012 .3	— —	1,030	440	.042
6001	.4724 12	1.1024 28	.3150 8	.012 .3	— —	1,150	540	.049
6002	.5906 15	1.2598 32	.3543 9	.012 .3	— —	1,260	635	.066
6003	.6693 17	1.3780 35	.3937 10	.012 .3	— —	1,530	755	.086
6004	.7874 20	1.6535 42	.4724 12	.024 .6	.020 .5	2,110	1,140	.152
60/22	.8661 22	1.7323 44	.4724 12	.024 .6	.020 .5	2,110	1,150	.163
6005	.9843 25	1.8504 47	.4724 12	.024 .6	.020 .5	2,260	1,320	.176
60/28	1.1024 28	2.0472 52	.4724 12	.024 .6	.020 .5	2,800	1,660	.216
6006	1.1811 30	2.1654 55	.5118 13	.039 1.0	.020 .5	2,970	1,860	.256
60/32A	1.2598 32	2.2835 58	.5118 13	.039 1.0	.020 .5	3,400	2,060	.284
6007	1.3780 35	2.4409 62	.5512 14	.039 1.0	.020 .5	3,600	2,310	.342
6008	1.5748 40	2.6772 68	.5906 15	.039 1.0	.020 .5	3,150	2,590	.423
6009	1.7717 45	2.9528 75	.6299 16	.039 1.0	.020 .5	4,700	3,400	.540
6010	1.9685 50	3.1496 80	.6299 16	.039 1.0	.020 .5	4,900	3,750	.575
6011	2.1654 55	3.5433 90	.7087 18	.043 1.1	.020 .5	6,350	4,800	.849
6012	2.3622 60	3.7402 95	.7087 18	.043 1.1	.020 .5	6,600	5,200	.915
6013	2.5591 65	3.9370 100	.7087 18	.043 1.1	.020 .5	6,850	5,650	.959
6014	2.7559 70	4.3307 110	.7874 20	.043 1.1	.020 .5	8,550	6,950	1.33
6015	2.9528 75	4.5276 115	.7874 20	.043 1.1	.020 .5	8,900	7,550	1.41
6016	3.1496 80	4.9213 125	.8661 22	.043 1.1	.020 .5	10,700	8,950	1.87
6017	3.3465 85	5.1181 130	.8661 22	.043 1.1	.020 .5	11,100	9,700	1.96
6018	3.5433 90	5.5118 140	.9449 24	.059 1.5	.020 .5	13,100	11,200	2.56
6019	3.7402 95	5.7087 145	.9449 24	.059 1.5	.020 .5	13,600	12,100	2.67
6020	3.9370 100	5.9055 150	.9449 24	.059 1.5	.020 .5	13,500	12,200	2.76
6021	4.1339 105	6.2992 160	1.0236 26	.079 2.0	.020 .5	16,300	14,800	3.51
6022	4.3307 110	6.6929 170	1.1024 28	.079 2.0	.020 .5	18,400	16,400	4.32
6024	4.7244 120	7.0866 180	1.1024 28	.079 2.0	— —	19,100	17,800	4.56
6026	5.1181 130	7.8740 200	1.2992 33	.079 2.0	— —	23,900	22,700	6.97
6028	5.5118 140	8.2677 210	1.2992 33	.079 2.0	— —	24,700	24,400	7.39
6030	5.9055 150	8.8583 225	1.3780 35	.083 2.1	— —	28,300	28,300	8.99
6032	6.2992 160	9.4488 240	1.4961 38	.083 2.1	— —	32,000	32,500	11.1
6034	6.6929 170	10.2362 260	1.6535 42	.083 2.1	— —	38,000	38,500	17.5
6036	7.0866 180	11.0236 280	1.8110 46	.083 2.1	— —	42,500	44,500	22.7
6038	7.4803 190	11.4173 290	1.8110 46	.083 2.1	— —	44,000	48,500	23.8
6040	7.8740 200	12.2047 310	2.0079 51	.083 2.1	— —	49,000	54,500	30.6

Continued on Page 22

SINGLE ROW RADIAL BALL BEARINGS

Units: INCHES
Millimeters



Snap Ring Groove Dimensions			Snap Ring Dimensions			Limiting Speed (RPM)			Bore Diameter No.
D_n (max)	a_n (max)	b_n (min)	E (max)	f (max)	e	Grease	Oil	LU, LLU	
—	—	—	—	—	—	29,000	34,000	21,000	00
—	—	—	—	—	—	—	—	—	—
—	—	—	—	—	—	26,000	30,000	18,000	01
—	—	—	—	—	—	—	—	—	—
—	—	—	—	—	—	22,000	26,000	15,000	02
—	—	—	—	—	—	—	—	—	—
—	—	—	—	—	—	20,000	24,000	14,000	03
—	—	—	—	—	—	—	—	—	—
1.565	.081	.065	1.82	.042	.125	18,000	21,000	11,000	04
39.75	2.06	1.65	46.3	1.07	3.17	—	—	—	—
1.644	.081	.053	1.90	.044	.129	17,000	20,000	10,000	/22
41.75	2.06	1.35	48.3	1.12	3.28	—	—	—	—
1.756	.081	.065	2.07	.042	.156	15,000	18,000	9,400	05
44.60	2.06	1.65	52.7	1.07	3.96	—	—	—	—
1.958	.081	.053	2.28	.044	.161	14,000	16,000	8,400	/28
49.73	2.06	1.35	57.9	1.12	4.09	—	—	—	—
—	—	—	—	—	—	—	—	—	—
2.071	.082	.065	2.39	.042	.156	13,000	15,000	7,700	06
52.60	2.08	1.65	60.7	1.07	3.96	—	—	—	—
2.189	.082	.053	2.51	.044	.159	12,000	15,000	7,200	/32
55.60	2.08	1.35	63.7	1.12	4.05	—	—	—	—
2.347	.082	.087	2.67	.065	.156	12,000	14,000	6,800	07
59.61	2.08	2.21	67.7	1.65	3.96	—	—	—	—
2.552	.098	.087	2.94	.065	.188	10,000	12,000	6,100	08
64.82	2.49	2.21	74.6	1.65	4.78	—	—	—	—
—	—	—	—	—	—	—	—	—	—
2.828	.098	.087	3.21	.065	.188	9,200	11,000	5,400	09
71.83	2.49	2.21	81.6	1.65	4.78	—	—	—	—
3.024	.098	.087	3.41	.065	.188	8,400	9,800	5,000	10
76.81	2.49	2.21	86.6	1.65	4.78	—	—	—	—
3.417	.113	.118	3.80	.095	.188	7,700	9,000	4,500	11
86.79	2.87	3.00	96.5	2.41	4.78	—	—	—	—
—	—	—	—	—	—	—	—	—	—
3.615	.113	.118	4.00	.095	.188	7,000	8,300	4,100	12
91.82	2.87	3.00	101.6	2.41	4.78	—	—	—	—
3.811	.113	.118	4.19	.095	.188	6,500	7,700	3,900	13
96.80	2.87	3.00	106.5	2.41	4.78	—	—	—	—
4.205	.113	.118	4.59	.095	.188	6,100	7,100	3,600	14
106.81	2.87	3.00	116.6	2.41	4.78	—	—	—	—
—	—	—	—	—	—	—	—	—	—
4.402	.113	.118	4.79	.095	.188	5,700	6,700	3,300	15
111.81	2.87	3.00	121.6	2.41	4.78	—	—	—	—
4.733	.113	.134	5.30	.109	.281	5,300	6,200	3,100	16
120.22	2.87	3.40	134.7	2.77	7.14	—	—	—	—
4.930	.113	.134	5.50	.109	.281	5,000	5,900	2,900	17
125.22	2.87	3.40	139.7	2.77	7.14	—	—	—	—
—	—	—	—	—	—	—	—	—	—
5.324	.146	.134	5.89	.109	.281	4,700	5,600	2,800	18
135.23	3.71	3.40	149.7	2.77	7.14	—	—	—	—
5.521	.146	.134	6.09	.109	.281	4,500	5,300	2,600	19
140.23	3.71	3.40	154.7	2.77	7.1	—	—	—	—
5.718	.146	.134	6.29	.109	.281	4,200	5,000	2,600	20
145.24	3.71	3.40	159.7	2.77	7.14	—	—	—	—
—	—	—	—	—	—	—	—	—	—
6.111	.146	.134	6.68	.109	.281	4,000	4,700	2,400	21
155.22	3.71	3.40	169.7	2.77	7.14	—	—	—	—
6.443	.146	.150	7.20	.120	.375	3,800	4,500	2,300	22
163.65	3.71	3.81	182.9	3.05	9.53	—	—	—	—
—	—	—	—	—	—	—	—	—	—
—	—	—	—	—	—	3,500	4,100	2,100	24
—	—	—	—	—	—	—	—	—	—
—	—	—	—	—	—	3,200	3,800	1,900	26
—	—	—	—	—	—	—	—	—	—
—	—	—	—	—	—	3,000	3,500	1,800	28
—	—	—	—	—	—	—	—	—	—
—	—	—	—	—	—	2,800	3,200	1,700	30
—	—	—	—	—	—	—	—	—	—
—	—	—	—	—	—	2,600	3,000	1,600	32
—	—	—	—	—	—	—	—	—	—
—	—	—	—	—	—	2,400	2,800	—	34
—	—	—	—	—	—	—	—	—	—
—	—	—	—	—	—	2,300	2,700	—	36
—	—	—	—	—	—	—	—	—	—
—	—	—	—	—	—	2,100	2,500	—	38
—	—	—	—	—	—	—	—	—	—
—	—	—	—	—	—	2,000	2,400	—	40

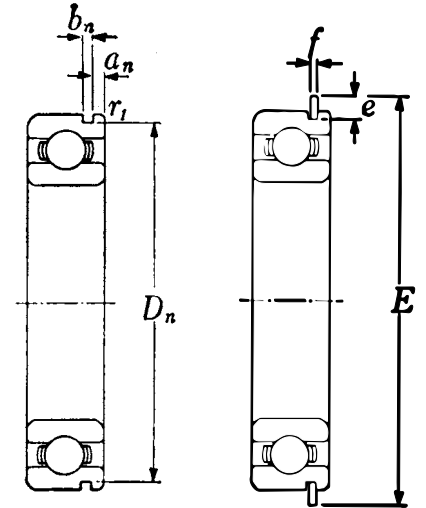

With Snap Ring Groove
60N

With Snap Ring
60NR



Single Shielded With Snap Ring
60ZNR

Continued on Page 23



Units: **INCHES**
Millimeters

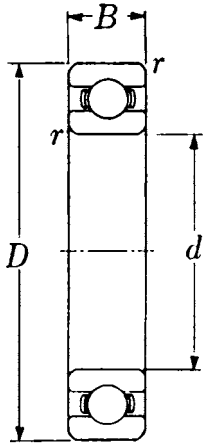

Open Type
60

SINGLE ROW RADIAL BALL BEARINGS

Bearing No.	Bore	O.D.	Width <i>B</i>	Fillet Radii		Basic Load Ratings (lbs)		Weight (lbs)
	<i>d</i>	<i>D</i>		<i>r</i>	<i>r₁</i>	Dynamic <i>C</i>	Static <i>C₀</i>	
6044	8.66	13.39	2.205	.118	—	54,500	65,000	34.6
	220	340	56	3.0				
6048	9.45	14.17	1.102	.118	—	56,000	70,000	37.0
	240	360	28	3.0				
6052	10.24	15.75	2.559	.157	—	65,500	84,500	55.1
	260	400	65	4.0				
6056	11.02	16.54	2.559	.157	—	73,000	95,000	68.3
	280	420	65	4.0				
6060	11.81	18.11	2.913	.157	—	80,000	108,000	96.6
	300	460	74	4.0				
6064	12.60	18.90	2.913	.157	—	83,500	119,000	102
	320	480	74	4.0				
6068	13.39	20.47	3.228	.197	—	94,000	137,000	136
	340	520	82	5.0				
6072	14.17	21.26	3.228	.197	—	98,500	150,000	143
	360	540	82	5.0				
6076	14.96	22.05	3.228	.197	—	103,000	163,000	149
	380	560	82	5.0				
6080	15.75	23.62	3.543	.197	—	114,000	185,000	193
	400	600	90	5.0				
6084	16.54	24.41	3.543	.197	—	119,000	201,000	201
	420	620	90	5.0				

SINGLE ROW RADIAL BALL BEARINGS

Units: **INCHES**
Millimeters



Snap Ring Groove Dimensions			Snap Ring Dimensions			Limiting Speed (RPM)			Bore Diameter No.
$D_n (max)$	$a_n (max)$	$b_n (min)$	$E (max)$	$f (max)$	e	Grease	Oil	LU, LLU	
—	—	—	—	—	—	1,800	2,200	—	44
—	—	—	—	—	—	1,700	2,000	—	48
—	—	—	—	—	—	1,500	1,800	—	52
—	—	—	—	—	—	1,400	1,600	—	56
—	—	—	—	—	—	1,300	1,500	—	60
—	—	—	—	—	—	1,200	1,400	—	64
—	—	—	—	—	—	1,100	1,300	—	68
—	—	—	—	—	—	1,100	1,200	—	72
—	—	—	—	—	—	990	1,200	—	76
—	—	—	—	—	—	930	1,100	—	80
—	—	—	—	—	—	880	1,000	—	84



Units: **INCHES**
Millimeters

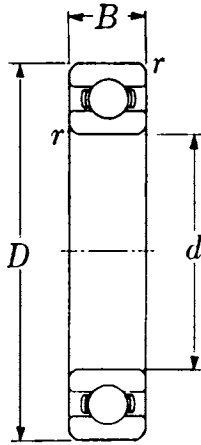

Open Type
62

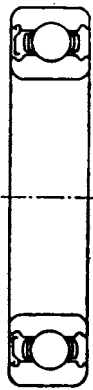

Single
Shielded
62Z



Double
Shielded
62ZZ

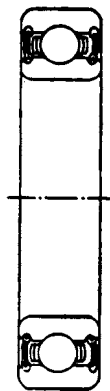

Double
Sealed
62LLU

(Contact Type)



Double
Sealed
62LLB

(Non-Contact Type)

SINGLE ROW RADIAL BALL BEARINGS

Bearing No.	Bore d	O.D. D	Width B	Fillet Radii		Basic Load Ratings (lbs)		Weight (lbs)
				r	r ₁	Dynamic C	Static C ₀	
6200	.3937 10	1.1811 30	.3543 9	.024 .6	.020 .5	1,150	540	.071
6201	.4724 12	1.2598 32	.3937 10	.024 .6	.020 .5	1,370	615	.082
6201/12.69	.4996 12.69	1.2598 32	.3937 10	.024 .6	.020 .5	1,370	615	.082
6201/12.695	.4998 12.695	1.2598 32	.3937 10	.024 .6	.020 .5	1,370	615	.082
6201/12.7	.5000 12.7	1.2598 32	.3937 10	.024 .6	.020 .5	1,370	615	.082
6201/13	.5118 13	1.2598 32	.3937 10	.024 .6	.020 .5	1,370	615	.082
6202	.5906 15	1.3780 35	.4331 11	.024 .6	—	1,740	805	.099
6202/12.71	.5004 12.71	1.3780 35	.4331 11	.024 .6	—	1,740	805	.099
6202/15.875	.6250 15.875	1.3780 35	.4331 11	.024 .6	—	1,740	805	.099
6202/16	.6299 16	1.3780 35	.4331 11	.024 .6	—	1,740	805	.099
6203	.6693 17	1.5748 40	.4724 12	.024 .6	.020 .5	2,160	1,030	.143
6203/12.7	.5000 12.7	1.5748 40	.4724 12	.024 .6	.020 .5	2,160	1,030	.143
6203/15.875	.6250 15.875	1.5748 40	.4724 12	.024 .6	.020 .5	2,160	1,030	.143
6203/16	.6299 16	1.5748 40	.4724 12	.024 .6	.020 .5	2,160	1,030	.143
6203/19.05	.7500 19.05	1.5748 40	.4724 12	.024 .6	.020 .5	2,160	1,030	.143
6204	.7874 20	1.8504 47	.5512 14	.039 1	.020 .5	2,890	1,500	.234
62/22	.8661 22	1.9685 50	.5512 14	.039 1	.020 .5	2,900	1,530	.258
6205	.9843 25	2.0472 52	.5906 15	.039 1	.020 .5	3,150	1,770	.282
6205/25.4	1.0000 25.4	2.0472 52	.5906 15	.039 1	.020 .5	3,150	1,770	.282
62/28	1.1024 28	2.2835 58	.6299 16	.039 1	.020 .5	4,000	2,190	.377
6206	1.1811 30	2.4409 62	.6299 16	.039 1	.020 .5	4,400	2,540	.439
62/32	1.2598 32	2.5591 65	.6693 17	.039 1	.020 .5	4,650	2,610	.498
6207	1.3780 35	2.8346 72	.6693 17	.043 1.1	.020 .5	5,750	3,450	.635
6208	1.5748 40	3.1496 80	.7087 18	.043 1.1	.020 .5	6,550	4,000	.807
6209	1.7717 45	3.3465 85	.7480 19	.043 1.1	.020 .5	7,350	4,600	.897
6210	1.9685 50	3.5433 90	.7874 20	.043 1.1	.020 .5	7,900	5,200	1.02
6211	2.1654 55	3.9370 100	.8268 21	.059 1.5	.020 .5	9,750	6,550	1.34
6212	2.3622 60	4.3307 110	.8661 22	.059 1.5	.020 .5	11,800	8,150	1.73
6213	2.5591 65	4.7244 120	.9055 23	.059 1.5	.020 .5	12,900	9,000	2.18
6214	2.7559 70	4.9213 125	.9449 24	.059 1.5	.020 .5	14,000	9,900	2.36
6215	2.9528 75	5.1181 130	.9843 25	.059 1.5	.020 .5	14,900	11,100	2.60
6216	3.1496 80	5.5118 140	1.0236 26	.079 2.0	.020 .5	16,500	11,900	3.09
6217	3.3465 85	5.9055 150	1.1024 28	.079 2.0	.020 .5	18,700	14,300	3.95
6218	3.5433 90	6.2992 160	1.1811 30	.079 2.0	.020 .5	21,600	16,100	4.74
6219	3.7402 95	6.6929 170	1.2598 32	.083 2.1	.020 .5	24,500	18,400	5.78
6220	3.9370 100	7.0866 180	1.3386 34	.083 2.1	.012 .5	27,500	20,900	6.92

Continued on Page 26

SINGLE ROW RADIAL BALL BEARINGS

Units: INCHES
Millimeters



Snap Ring Groove Dimensions			Snap Ring Dimensions			Limiting Speed (RPM)			Bore Diameter No.
D_n (max)	a_n (max)	b_n (min)	E (max)	f	e	Grease	Oil	LLU	
1.109	.081	.065	1.37	.042	.125	25,000	30,000	18,000	00
28.17	2.06	1.65	34.7	1.07	3.17				
1.187	.081	.065	1.44	.042	.125	22,000	26,000	16,000	01
30.15	2.06	1.65	36.7	1.07	3.17				
1.187	.081	.065	1.44	.042	.125	22,000	26,000	16,000	01
30.15	2.06	1.65	36.7	1.07	3.17				
1.187	.081	.065	1.44	.042	.125	22,000	26,000	16,000	01
30.15	2.06	1.65	36.7	1.07	3.17				
1.187	.081	.065	1.44	.042	.125	22,000	26,000	16,000	01
30.15	2.06	1.65	36.7	1.07	3.17				
1.306	.081	.065	1.56	.042	.125	19,000	23,000	15,000	02
33.17	2.06	1.65	39.7	1.07	3.17				
1.306	.081	.065	1.56	.042	.125	19,000	23,000	15,000	02
33.17	2.06	1.65	39.7	1.07	3.17				
1.306	.081	.065	1.56	.042	.125	19,000	23,000	15,000	02
33.17	2.06	1.65	39.7	1.07	3.17				
1.306	.081	.065	1.56	.042	.125	19,000	23,000	15,000	02
33.17	2.06	1.65	39.7	1.07	3.17				
1.500	.081	.065	1.76	.042	.125	18,000	21,000	12,000	03
38.10	2.06	1.65	44.6	1.07	3.17				
1.500	.081	.065	1.76	.042	.125	18,000	21,000	12,000	03
38.10	2.06	1.65	44.6	1.07	3.17				
1.500	.081	.065	1.76	.042	.125	18,000	21,000	12,000	03
38.10	2.06	1.65	44.6	1.07	3.17				
1.500	.081	.065	1.76	.042	.125	18,000	21,000	12,000	03
38.10	2.06	1.65	44.6	1.07	3.17				
1.500	.081	.065	1.76	.042	.125	18,000	21,000	12,000	03
38.10	2.06	1.65	44.6	1.07	3.17				
1.756	.097	.065	2.07	.042	.156	16,000	18,000	10,000	04
44.60	2.46	1.65	52.7	1.07	3.96				
1.874	.097	.065	2.19	.042	.156	14,000	17,000	9,700	/22
47.60	2.46	1.65	55.7	1.07	3.96				
1.958	.097	.065	2.28	.042	.156	13,000	15,000	8,900	05
49.73	2.46	1.65	57.9	1.07	3.96				
1.958	.097	.065	2.28	.042	.156	13,000	15,000	8,900	05
49.73	2.46	1.65	57.9	1.07	3.96				
2.189	.097	.065	2.51	.042	.156	12,000	14,000	8,100	/28
55.60	2.46	1.65	63.7	1.07	3.96				
2.347	.129	.087	2.67	.065	.156	11,000	13,000	7,300	06
59.61	3.28	2.21	67.7	1.65	3.96				
2.465	.129	.087	2.78	.065	.156	11,000	12,000	7,100	/32
62.61	3.28	2.21	70.7	1.65	3.96				
2.709	.129	.087	3.09	.065	.188	9,800	11,000	6,300	07
68.81	3.28	2.21	78.6	1.65	4.77				
3.024	.129	.087	3.41	.065	.188	8,700	10,000	5,600	08
76.81	3.28	2.21	86.6	1.65	4.77				
3.221	.129	.087	3.61	.065	.188	7,800	9,200	5,200	09
81.81	3.28	2.21	91.6	1.65	4.77				
3.417	.129	.118	3.80	.095	.188	7,100	8,300	4,700	10
86.79	3.28	3.00	96.5	2.41	4.77				
3.811	.129	.118	4.19	.095	.188	6,400	7,600	4,300	11
96.80	3.28	3.00	106.5	2.41	4.77				
4.205	.129	.118	4.59	.095	.188	6,000	7,000	3,800	12
106.81	3.28	3.00	116.6	2.41	4.77				
4.536	.160	.134	5.11	.109	.281	5,500	6,500	3,600	13
115.21	4.06	3.40	129.7	2.77	7.13				
4.733	.160	.134	5.30	.109	.281	5,100	6,000	3,400	14
120.22	4.06	3.40	134.7	2.77	7.13				
4.930	.160	.134	5.50	.109	.281	4,800	5,600	3,200	15
125.22	4.06	3.40	139.7	2.77	7.13				
5.324	.193	.134	5.89	.109	.281	4,500	5,300	3,000	16
135.23	4.90	3.40	149.7	2.77	7.13				
5.718	.193	.134	6.29	.109	.281	4,200	5,000	2,800	17
145.24	4.90	3.40	159.7	2.77	7.13				
6.111	.193	.134	6.68	.109	.281	4,000	4,700	2,600	18
155.22	4.90	3.40	169.7	2.77	7.13				
6.443	.224	.150	7.20	.120	.375	3,700	4,400	2,500	19
163.65	5.69	3.81	182.9	3.05	9.52				
6.837	.224	.150	7.59	.120	.375	3,500	4,200	2,300	20
173.66	5.69	3.81	192.9	3.05	9.52				

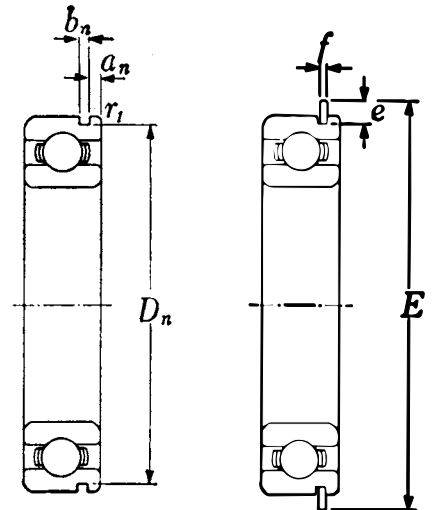

With Snap Ring Groove 62N

With Snap Ring 62NR

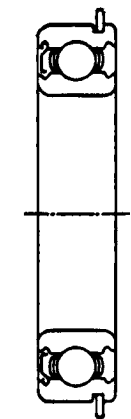

Single Shielded With Snap Ring 62ZNR

Continued on Page 27



Units: **INCHES**
Millimeters

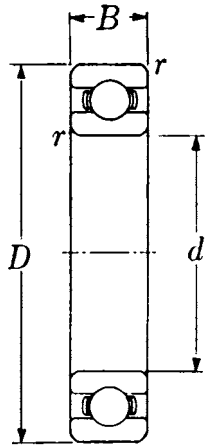

Open Type
62

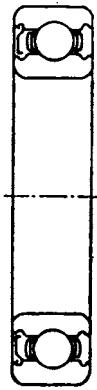

Single
Shielded
62Z



Double
Shielded
62ZZ

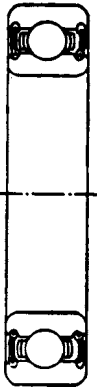

Double
Sealed
62LLU
(Contact Type)



Double
Sealed
62LLB
(Non-Contact Type)

SINGLE ROW RADIAL BALL BEARINGS

Bearing No.	Bore	O.D.	Width	Fillet Radii		Basic Load Ratings (lbs)		Weight (lbs)
	d	D	B	r	r ₁	Dynamic C	Static C ₀	
6221	4.1339 105	7.4803 190	1.4173 36	.083 2.1	.020 .5	29,900	23,500	8.16
6222	4.3307 110	7.8740 200	1.4961 38	.083 2.1	.020 .5	32,500	26,300	9.61
6224	4.7244 120	8.4646 215	1.5748 40	.083 2.1	—	35,000	29,500	11.4
6226	5.1181 130	9.0551 230	1.5748 40	.118 3.0	—	37,500	33,000	12.8
6228	5.5118 140	9.8425 250	1.6535 42	.118 3.0	—	37,500	33,500	16.5
6230	5.9055 150	10.6299 270	1.7717 45	.118 3.0	—	39,500	37,500	20.7
6232	6.2992 160	11.4173 290	1.8898 48	.118 3.0	—	41,500	42,000	31.5
6234	6.6929 170	12.2047 310	2.0472 52	.157 4.0	—	47,500	50,000	38.6
6236	7.0866 180	12.5984 320	2.0472 52	.157 4.0	—	51,000	54,000	40.3
6238	7.4803 190	13.3858 340	2.1654 55	.157 4.0	—	57,500	63,500	50.7
6240	7.8740 200	14.1732 360	2.2835 58	.157 4.0	—	60,800	70,000	62.2
6244	8.6614 220	15.7480 400	2.5590 65	.157 4.0	—	67,000	81,500	66.6

SINGLE ROW RADIAL BALL BEARINGS

Units: INCHES
Millimeters



Snap Ring Groove Dimensions			Snap Ring Dimensions			Limiting Speed (RPM)			Bore Diameter No.
D_n (max)	a_n (max)	b_n (min)	E (max)	f (max)	e	Grease	Oil	LU, LLU	
7.230	.224	.150	7.99	.120	.375	3,400	4,000	2,300	21
183.64	5.69	3.81	202.9	3.05	9.52				
7.624	.224	.150	8.38	.120	.375	3,200	3,800	2,200	22
193.65	5.69	3.81	212.9	3.05	9.52				
—	—	—	—	—	—	2,900	3,400	2,000	24
—	—	—	—	—	—	2,300	2,700	—	26
—	—	—	—	—	—	2,100	2,500	—	28
—	—	—	—	—	—	2,000	2,400	—	30
—	—	—	—	—	—	1,900	2,200	—	32
—	—	—	—	—	—	1,800	2,100	—	34
—	—	—	—	—	—	1,700	1,800	—	36
—	—	—	—	—	—	1,800	2,100	—	38
—	—	—	—	—	—	1,700	2,000	—	40
—	—	—	—	—	—	1,500	1,800	—	44

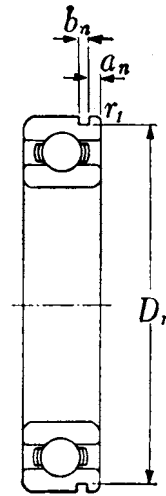

With Snap Ring Groove
62N

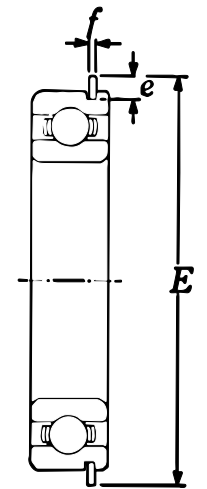

With Snap Ring
62NR

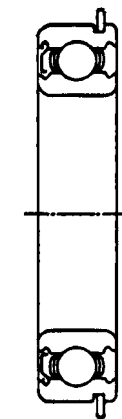

Single Shielded With Snap Ring
62ZNR



Units: INCHES
Millimeters

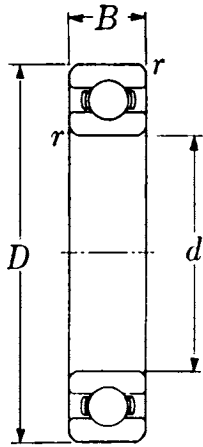

Open Type
63

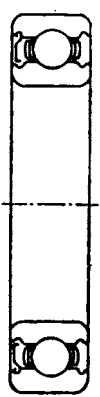

Single
Shielded
63Z

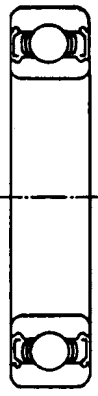

Double
Shielded
63ZZ



Double
Sealed
63LLU



Double
Sealed
63LLB

(Contact Type) (Non-Contact Type)

SINGLE ROW RADIAL BALL BEARINGS

Bearing No.	Bore	O.D.	Width	Fillet Radii		Basic Load Ratings (lbs)		Weight (lbs)
	d	D		r	r ₁	Dynamic C	Static C ₀	
6300	.3937 10	1.3780 35	.4331 11	.024 .6	.020 .5	1,840	785	.117
6301	.4724 12	1.4567 37	.4724 12	.039 1.0	.020 .5	2,180	940	.132
6302	.5906 15	1.6535 42	.5118 13	.039 1.0	.020 .5	2,570	1,220	.181
6303	.6693 17	1.8504 47	.5512 14	.039 1.0	.020 .5	3,050	1,470	.254
6304	.7874 20	2.0472 52	.5906 15	.043 1.1	.020 .5	3,600	1,770	.317
63/22	.8661 22	2.2047 56	.6299 16	.043 1.1	.020 .5	4,150	2,080	.388
6305	.9843 25	2.4409 62	.6693 17	.043 1.1	.020 .5	4,750	2,460	.511
63/28	1.1024 28	2.6772 68	.7087 18	.043 1.1	.020 .5	6,000	3,150	.633
6306	1.1811 30	2.8346 72	.7480 19	.043 1.1	.020 .5	6,000	3,400	.763
63/32	1.2598 32	2.9528 75	.7874 20	.043 1.1	.020 .5	6,700	3,800	.842
6307	1.3780 35	3.1496 80	.8268 21	.059 1.5	.020 .5	7,500	4,300	1.01
6308	1.5748 40	3.5433 90	.9055 23	.059 1.5	.020 .5	9,150	5,400	1.40
6309	1.7717 45	3.9370 100	.9843 25	.059 1.5	.020 .5	11,900	7,200	1.84
6310	1.9685 50	4.3307 110	1.0630 27	.079 2.0	.020 .5	13,900	8,600	2.36
6311	2.1654 55	4.7244 120	1.1417 29	.079 2.0	.020 .5	16,100	10,100	3.02
6312	2.3622 60	5.1181 130	1.2205 31	.083 2.1	.020 .5	18,400	11,700	3.75
6313	2.5591 65	5.5118 140	1.2992 33	.083 2.1	.020 .5	20,800	13,400	4.59
6314	2.7559 70	5.9055 150	1.3780 35	.083 2.1	.020 .5	23,400	15,300	5.56
6315	2.9528 75	6.2992 160	1.4567 37	.083 2.1	.020 .5	25,500	17,400	6.66
6316	3.1496 80	6.6929 170	1.5354 39	.083 2.1	.020 .5	27,600	19,500	7.91
6317	3.3465 85	7.0866 180	1.6142 41	.118 3.0	.020 .5	29,800	21,800	9.33
6318	3.5433 90	7.4803 190	1.6929 43	.118 3.0	.020 .5	32,000	24,100	10.8
6319	3.7402 95	7.8740 200	1.7717 45	.118 3.0	.020 .5	34,500	26,600	12.5
6320	3.9370 100	8.4646 215	1.8504 47	.118 3.0	—	39,000	31,500	15.4
6321	4.1339 105	8.8583 225	1.9291 49	.118 3.0	—	41,500	34,500	17.7
6322	4.3307 110	9.4488 240	1.9685 50	.118 3.0	—	46,000	40,500	21.0
6324	4.7244 120	10.2362 260	2.1654 55	.118 3.0	—	46,500	41,500	27.3
6326	5.1181 130	11.0236 280	2.2835 58	.157 4.0	—	51,500	48,000	33.3
6328	5.5118 140	11.8110 300	2.4409 62	.157 4.0	—	57,000	55,500	40.8
6330	5.9055 150	12.5984 320	2.5591 65	.157 4.0	—	61,500	63,500	57.8
6332	6.2992 160	13.3858 340	2.6772 68	.157 4.0	—	62,500	64,500	63.9
6334	6.6929 170	14.1732 360	2.8346 72	.157 4.0	—	73,500	80,000	76.1
6336	7.0866 180	14.9606 380	2.9528 75	.157 4.0	—	79,500	91,500	93.5
6338	7.4803 190	15.7480 400	3.0709 78	.197 5.0	—	79,500	93,000	108
6340	7.8740 200	16.5354 420	3.1496 80	.197 5.0	—	92,000	113,000	122
6344	8.6614 220	18.1102 460	3.4650 88	.157 4.0	—	92,500	116,000	134

SINGLE ROW RADIAL BALL BEARINGS

Units: **INCHES**
Millimeters



Snap Ring Groove Dimensions			Snap Ring Dimensions			Limiting Speed (RPM)			Bore Diameter No.
D_n (max)	a_n (max)	b_n (min)	E (max)	f (max)	e	Grease	Oil	LU, LLU	
1.306	.081	.065	1.56	.042	.125	23,000	27,000	16,000	00
33.17	2.06	1.65	39.7	1.07	3.18				
1.369	.081	.065	1.63	.042	.125	20,000	24,000	15,000	01
34.77	2.06	1.65	41.3	1.07	3.18				
1.565	.081	.065	1.82	.042	.125	17,000	21,000	12,000	02
39.75	2.06	1.65	46.3	1.07	3.18				
1.756	.097	.065	2.07	.042	.156	16,000	19,000	11,000	03
44.60	2.46	1.65	52.7	1.07	3.96				
1.958	.097	.065	2.28	.042	.156	14,000	17,000	10,000	04
49.73	2.46	1.65	57.9	1.07	3.96				
2.110	.097	.065	2.43	.042	.156	13,000	15,000	9,200	/22
53.59	2.46	1.65	61.7	1.07	3.96				
2.347	.129	.087	2.67	.065	.156	12,000	14,000	8,100	05
59.61	3.28	2.20	67.7	1.65	3.96				
2.552	.129	.087	2.94	.065	.188	11,000	13,000	7,400	/28
64.82	3.28	2.20	74.6	1.65	4.77				
2.709	.129	.087	3.09	.065	.188	10,000	12,000	6,600	06
68.81	3.28	2.20	78.6	1.65	4.77				
2.828	.129	.087	3.21	.065	.188	9,500	11,000	6,500	/32
71.83	3.28	2.20	81.6	1.65	4.77				
3.024	.129	.087	3.41	.065	.188	8,800	10,000	6,000	07
76.81	3.28	2.20	86.6	1.65	4.77				
3.417	.129	.118	3.80	.095	.188	7,800	9,200	5,300	08
86.79	3.28	3.00	96.5	2.41	4.77				
3.811	.129	.118	4.19	.095	.188	7,000	8,200	4,700	09
96.80	3.28	3.00	106.5	2.41	4.77				
4.205	.129	.118	4.59	.095	.188	6,400	7,500	4,200	10
106.81	3.28	3.00	116.6	2.41	4.77				
4.536	.160	.134	5.11	.109	.281	5,800	6,800	3,900	11
115.21	4.06	3.40	129.7	2.77	7.13				
4.930	.160	.134	5.50	.109	.281	5,400	6,300	3,600	12
125.22	4.06	3.40	139.7	2.77	7.13				
5.324	.193	.134	5.89	.109	.281	4,900	5,800	3,300	13
135.23	4.90	3.40	149.7	2.77	7.13				
5.718	.193	.134	6.29	.109	.281	4,600	5,400	3,100	14
145.24	4.90	3.40	159.7	2.77	7.13				
6.111	.193	.134	6.68	.109	.281	4,300	5,000	2,900	15
155.22	4.90	3.40	169.7	2.77	7.13				
6.443	.224	.150	7.20	.120	.375	4,000	4,700	2,700	16
163.65	5.69	3.80	182.9	3.05	9.52				
6.837	.224	.150	7.59	.120	.375	3,800	4,500	2,600	17
173.66	5.69	3.80	192.9	3.05	9.52				
7.230	.224	.150	7.99	.120	.375	3,600	4,200	2,400	18
183.64	5.69	3.80	202.9	3.05	9.52				
7.624	.224	.150	8.38	.120	.375	3,300	3,900	2,300	19
193.65	5.69	3.80	212.9	3.05	9.52				
—	—	—	—	—	—	3,200	3,700	2,200	20
—	—	—	—	—	—	3,000	3,600	2,100	21
—	—	—	—	—	—	2,900	3,400	1,900	22
—	—	—	—	—	—	2,600	3,100	—	24
—	—	—	—	—	—	2,400	2,800	—	26
—	—	—	—	—	—	2,200	2,600	—	28
—	—	—	—	—	—	2,100	2,400	—	30
—	—	—	—	—	—	1,900	2,300	—	32
—	—	—	—	—	—	1,800	2,100	—	34
—	—	—	—	—	—	1,700	2,000	—	36
—	—	—	—	—	—	1,600	1,900	—	38
—	—	—	—	—	—	1,500	1,800	—	40
—	—	—	—	—	—	1,400	1,600	—	44

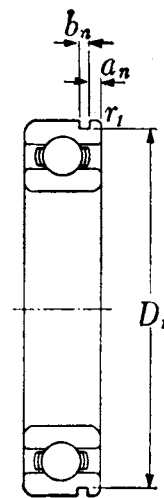

With Snap Ring Groove 63N

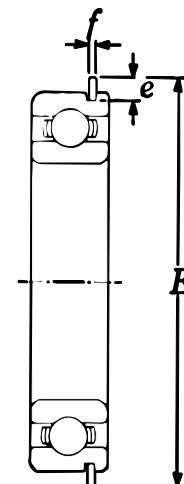

With Snap Ring 63NR

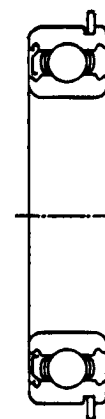

Single Shielded With Snap Ring 63ZNR



Units: INCHES
Millimeters

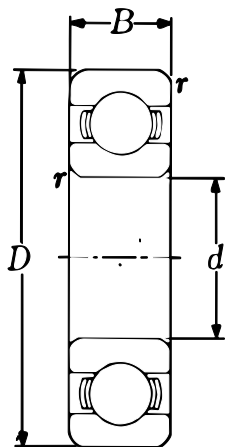

Open Type
64



Double Sealed
64LLB
(Contact Type)



Double
Shielded
64ZZ

SINGLE ROW RADIAL BALL BEARINGS

Bearing Number	Bore		Width B	Fillet Radius r	Basic Load Ratings (lbs)		Weight (lbs)	Limiting Speed (RPM)			Bore Dia. No.
	d	D			Dynamic C	Static C ₀		Grease	Oil	LU,LLU	
6403	.6693 17	2.4409 62	.6693 17	.043 1.1	5,100	2,420	.595	14,000	16,000	9,500	03
6404	.7874 20	2.8346 72	.7480 19	.043 1.1	6,400	3,150	.882	12,000	14,000	8,000	04
6405	.9843 25	3.1496 80	.8268 21	.059 1.5	7,800	3,950	1.17	10,000	12,000	6,900	05
6406	1.1811 30	3.5433 90	.9055 23	.059 1.5	9,750	5,350	1.62	8,800	10,000	5,800	06
6407	1.3780 35	3.9370 100	.9843 25	.059 1.5	12,400	7,000	2.10	7,800	9,100	5,100	07
6408	1.5748 40	4.3307 110	1.0630 27	.079 2.0	14,300	8,200	2.71	7,000	8,200	4,700	08
6409	1.7717 45	4.7244 120	1.1417 29	.079 2.0	17,300	10,100	3.37	6,300	7,400	4,300	09
6410	1.9685 50	5.1181 130	1.2205 31	.083 2.1	18,700	11,100	4.14	5,700	6,700	—	10
6411	2.1654 55	5.5118 140	1.2992 33	.083 2.1	20,000	12,100	5.05	5,200	6,100	—	11
6412	2.3622 60	5.9055 150	1.3780 35	.083 2.1	22,900	14,400	6.11	4,800	5,700	—	12
6413	2.5591 65	6.2992 160	1.4567 37	.083 2.1	24,900	16,200	7.28	4,400	5,200	—	13
6414	2.7559 70	7.0866 180	1.6535 42	.118 3.0	28,800	20,100	10.6	4,100	4,800	—	14
6415	2.9528 75	7.4803 190	1.7717 45	.118 3.0	31,000	22,300	12.6	3,800	4,500	—	15
6416	3.1496 80	7.8740 200	1.8898 48	.118 3.0	37,000	28,200	14.9	3,600	4,200	—	16
6417	3.3465 85	8.2677 210	2.0472 52	.157 4.0	37,000	28,700	17.5	3,400	4,000	—	17
6418	3.5433 90	8.8583 225	2.1260 54	.157 4.0	41,500	33,500	25.1	3,200	3,800	—	18
6419	3.7402 95	9.4488 240	2.1654 55	.157 4.0	42,000	34,500	29.5	3,000	3,500	—	19
6420	3.9370 100	9.8425 250	2.2835 58	.157 4.0	46,000	39,500	33.1	2,900	3,400	—	20
6421	4.1339 105	10.2362 260	2.3622 60	.157 4.0	46,500	40,000	37.0	2,700	3,200	—	21
6422	4.3307 110	11.0236 280	2.5591 65	.157 4.0	55,500	51,000	47.0	2,600	3,000	—	22
6424	4.7244 120	12.2047 310	2.8346 72	.197 5.0	65,500	64,500	63.9	2,300	2,800	—	24
6426	5.1181 130	13.3858 340	3.0709 78	.197 5.0	68,000	67,000	83.8	2,200	2,500	—	26

SINGLE ROW RADIAL BALL BEARINGS

Units: INCHES
Millimeters

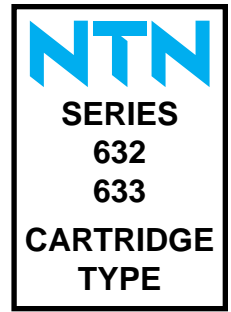

Bearing No.	Bore	O.D.	Width	Fillet Radius	Basic Load Ratings (lbs)		Weight (lbs)
	d	D	B	r	Dynamic C	Static C ₀	
63204ZZ	.7874 20	1.8504 47	.8110 20.6	.039 1.0	2,870	1,500	.34
63205ZZ	.9843 25	2.0472 52	.8110 20.6	.039 1.0	3,150	1,770	.39
63206ZZ	1.1811 30	2.4409 62	.9370 23.8	.039 1.0	4,400	2,540	.63
63207ZZ	1.3780 35	2.8346 72	1.0630 27.0	.043 1.1	5,750	3,450	.96
63208ZZ	1.5748 40	3.1496 80	1.1890 30.2	.043 1.1	6,550	4,000	1.28
63209ZZ	1.7717 45	3.3465 85	1.1890 30.2	.043 1.1	7,350	4,600	1.37
63210ZZ	1.9685 50	3.5433 90	1.1890 30.2	.043 1.1	7,900	5,200	1.45
63211ZZ	2.1654 55	3.9370 100	1.3110 33.3	.059 1.5	9,750	6,550	2.04
63212ZZ	2.3622 60	4.3307 110	1.4370 36.5	.059 1.5	11,800	8,150	2.80
63304ZZ	.7874 20	2.0472 52	.8740 22.2	.043 1.1	3,600	1,770	.48
63305ZZ	.9843 25	2.4409 62	1.0000 25.4	.043 1.1	4,750	2,460	.78
63306ZZ	1.1811 30	2.8346 72	1.1890 30.2	.043 1.1	6,000	3,400	1.13
63307ZZ	1.3780 35	3.1496 80	1.3740 34.9	.059 1.5	7,500	4,300	1.64
63308ZZ	1.5748 40	3.5433 90	1.4370 36.5	.059 1.5	9,150	5,400	2.06
63309ZZ	1.7717 45	3.9370 100	1.5630 39.7	.059 1.5	11,900	7,200	3.00
63310ZZ	1.9685 50	4.3307 110	1.7480 44.4	.079 2.0	13,900	8,600	3.75
63311ZZ	2.1654 55	4.7244 120	1.9370 49.2	.079 2.0	16,100	10,100	5.12
63312ZZ	2.3622 60	5.1181 130	2.1260 54.0	.083 2.1	18,400	11,700	6.50
63313ZZ	2.5591 65	5.5118 140	2.3110 58.7	.083 2.1	20,800	13,400	8.17
63314ZZ	2.7559 70	5.9055 150	2.5000 63.5	.083 2.1	23,400	15,300	10.5
63315ZZ	2.9528 75	6.2992 160	2.6890 68.3	.083 2.1	25,500	17,400	12.5
63316ZZ	3.1496 80	6.6929 170	2.6890 68.3	.083 2.1	27,600	19,500	14.1
63317ZZ	3.3465 85	7.0866 180	2.8740 73.0	.118 3.0	29,800	21,800	16.9
63318ZZ	3.5433 90	7.4803 190	2.8740 73.0	.118 3.0	32,000	24,100	18.7
63320ZZ	3.9370 100	8.4646 215	3.2500 82.55	.118 3.0	39,000	31,500	26.72

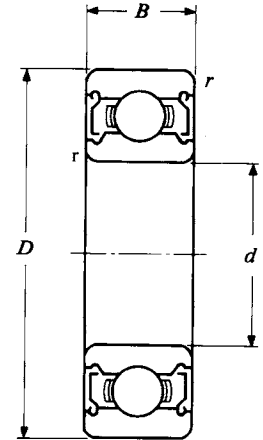

NTN
SERIES
BL2

Maximum
Type

Units: INCHES
Millimeters

SINGLE ROW RADIAL BALL BEARINGS

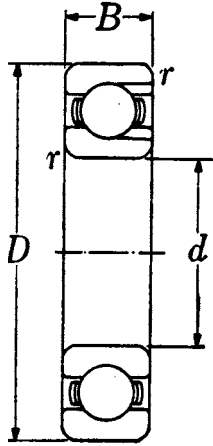

Open Type

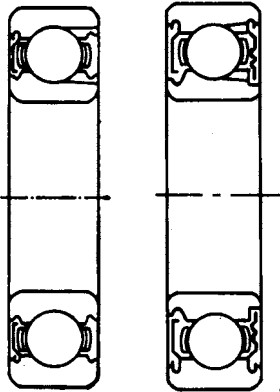

Single
Shielded
Z

Double
Shielded
ZZ

Bearing No.	Bore	O.D.	Width B	Fillet Radii		Basic Load Ratings (lbs)		Weight (lbs)
	d	D		r	r ₁	Dynamic C	Static C ₀	
BL205	.9843 25	2.0472 52	.5906 15	.039 1	.020 .5	3,800	2,360	.312
BL2/28	1.1024 28	2.2835 58	.6299 16	.039 1	.020 .5	5,250	3,300	.420
BL206	1.1811 30	2.4409 62	.6299 16	.039 1	.020 .5	5,600	3,650	.471
BL2/32	1.2598 32	2.5591 65	.6693 17	.039 1	.020 .5	6,100	3,900	.540
BL207	1.3780 35	2.8346 72	.6693 17	.043 1.1	.020 .5	7,400	4,950	.700
BL208	1.5748 40	3.1496 80	.7087 18	.043 1.1	.020 .5	8,800	6,250	.880
BL209	1.7717 45	3.3465 85	.7480 19	.043 1.1	.020 .5	9,900	7,150	1.00
BL210	1.9685 50	3.5433 90	.7874 20	.043 1.1	.020 .5	10,300	7,850	1.10
BL211	2.1654 55	3.9370 100	.8268 21	.059 1.5	.020 .5	12,800	9,850	1.50
BL212	2.3622 60	4.3307 110	.8661 22	.059 1.5	.020 .5	15,500	12,200	1.90
BL213	2.5591 65	4.7244 120	.9055 23	.059 1.5	.020 .5	16,900	13,500	2.40
BL214	2.7559 70	4.9213 125	.9449 24	.059 1.5	.020 .5	18,300	14,900	2.60
BL215	2.9528 75	5.1181 130	.9843 25	.059 1.5	.020 .5	19,100	16,100	2.79
BL216	3.1496 80	5.5118 140	1.0236 26	.079 2.0	.020 .5	22,400	19,100	3.50
BL217	3.3465 85	5.9055 150	1.1024 28	.079 2.0	.020 .5	24,000	20,800	4.49
BL218	3.5433 90	6.2992 160	1.1811 30	.079 2.0	.020 .5	29,500	25,700	5.50
BL219	3.7402 95	6.6929 170	1.2598 32	.079 2.0	.020 .5	32,000	27,600	6.82
BL220	3.9370 100	7.0866 180	1.3386 34	.079 2.0	.020 .5	36,000	31,500	8.03
BL221	4.1339 105	7.4803 190	1.4173 36	.079 2.0	.020 .5	39,000	35,500	9.72
BL222	4.3307 110	7.8740 200	1.4961 38	.079 2.0	.020 .5	42,500	39,500	11.3

SINGLE ROW RADIAL BALL BEARINGS

Units: **INCHES**
Millimeters



Snap Ring Dimensions		f	Limiting Speed (RPM)		Bore Diameter No.
a_n (max)	E (max)		Grease	Oil	
.097	2.28	.042	12,000	14,000	05
2.46	57.9	1.07			
.097	2.51	.042	11,000	13,000	/28
2.46	63.7	1.07			
.129	2.67	.065	10,000	12,000	06
3.28	67.7	1.65			
.129	2.78	.065	9,500	11,000	/32
3.28	70.7	1.65			
.129	3.09	.065	8,800	10,000	07
3.28	78.6	1.65			
.129	3.41	.065	7,800	9,200	08
3.28	86.6	1.65			
.129	3.61	.065	7,000	8,200	09
3.28	91.6	1.65			
.129	3.80	.095	6,400	7,500	10
3.28	96.5	2.41			
.129	4.19	.095	5,800	6,800	11
3.28	106.5	2.41			
.129	4.59	.095	5,400	6,300	12
3.28	116.6	2.41			
.160	5.11	.109	4,900	5,800	13
4.06	129.7	2.77			
.160	5.30	.109	4,600	5,400	14
4.06	134.7	2.77			
.160	5.50	.109	4,300	5,000	15
4.06	139.7	2.77			
.193	5.89	.109	4,000	4,700	16
4.90	149.7	2.77			
.193	6.29	.109	3,800	4,400	17
4.90	159.7	2.77			
.193	6.68	.109	3,600	4,200	18
4.90	169.7	2.77			
.224	7.20	.120	3,400	3,900	18
5.69	182.9	3.05			
.224	7.59	.120	3,200	3,700	20
5.69	192.9	3.05			
.224	7.99	.120	3,000	3,600	21
5.69	202.9	3.05			
.224	8.38	.120	2,900	3,400	22
5.69	212.9	3.05			

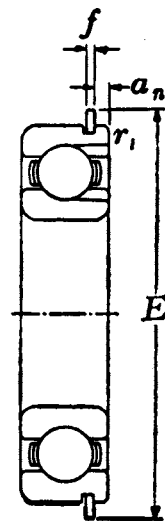

With Snap Ring
NR



Single Shielded
With Snap Ring
ZNR



Units: INCHES
Millimeters

SINGLE ROW RADIAL BALL BEARINGS

Bearing No.	Bore	O.D.	Width B	Fillet Radii		Basic Load Ratings (lbs)		Weight (lbs)
	d	D		r	r ₁	Dynamic C	Static C ₀	
BL304	.7874 20	2.0472 52	.5906 15	.043 1.1	.020 .5	4,550	2,530	.359
BL3/22	.8661 22	2.2047 56	.6299 16	.043 1.1	.020 .5	5,250	2,980	.440
BL305	.9843 25	2.4409 62	.6693 17	.043 1.1	.020 .5	6,050	3,500	.568
BL3/28	1.1024 28	2.6772 68	.7087 18	.043 1.1	.020 .5	7,600	4,500	.720
BL306	1.1811 30	2.8346 72	.7480 19	.043 1.1	.020 .5	7,400	4,650	.858
BL3/32	1.2598 32	2.9528 75	.7874 20	.043 1.1	.020 .5	8,300	5,250	.960
BL307	1.3780 35	3.1496 80	.8268 21	.059 1.5	.020 .5	9,800	6,450	1.10
BL308	1.5748 40	3.5433 90	.9055 23	.059 1.5	.020 .5	12,300	8,050	1.50
BL309	1.7717 45	3.9370 100	.9843 25	.059 1.5	.020 .5	14,700	9,900	2.10
BL310	1.9685 50	4.3307 110	1.0630 27	.079 2.0	.020 .5	17,200	11,800	2.68
BL311	2.1654 55	4.7244 120	1.1417 29	.079 2.0	.020 .5	21,100	15,200	3.41
BL312	2.3622 60	5.1181 130	1.2205 31	.079 2.0	.020 .5	24,100	17,600	4.22
BL313	2.5591 65	5.5118 140	1.2992 33	.079 2.0	.020 .5	27,300	20,200	5.19
BL314	2.7559 70	5.9055 150	1.3780 35	.079 2.0	.020 .5	30,500	23,000	6.49
BL315	2.9528 75	6.2992 160	1.4567 37	.079 2.0	.020 .5	33,500	26,000	7.92
BL316	3.1496 80	6.6929 170	1.5354 39	.079 2.0	.020 .5	36,000	29,200	8.69
BL317	3.3465 85	7.0866 180	1.6142 41	.118 3.0	.020 .5	39,000	32,500	10.3
BL318	3.5433 90	7.4803 190	1.6929 43	.118 3.0	.020 .5	42,000	36,000	13.0
BL319	3.7402 95	7.8740 200	1.7717 45	.118 3.0	.020 .5	45,000	40,000	15.0
BL320	3.9370 100	8.4646 215	1.8504 47	.118 3.0	—	51,000	47,500	18.3
BL321	4.1339 105	8.8583 225	1.9291 49	.118 3.0	—	54,000	52,000	20.8
BL322	4.3307 110	9.4488 240	1.9685 50	.118 3.0	—	60,500	60,500	24.3

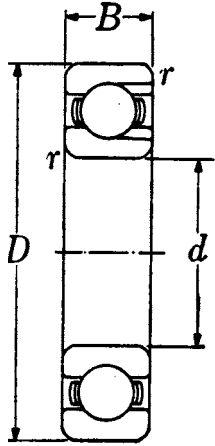

Open Type

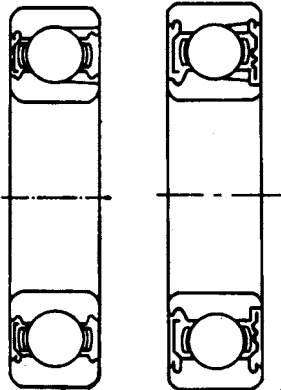

Single Shielded
Z

Double Shielded
ZZ

SINGLE ROW RADIAL BALL BEARINGS

Units: **INCHES**
Millimeters



Snap Ring Dimensions		f	Limiting Speed (RPM)		Bore Diameter No.
a_n (max)	E (max)		Grease	Oil	
.097	2.28	.042	13,000	15,000	04
2.46	57.9	1.07			
.097	2.43	.042	12,000	14,000	/22
2.46	61.7	1.07			
.129	2.67	.065	11,000	12,000	05
3.28	67.7	1.65			
.129	2.94	.065	9,600	11,000	/28
3.28	74.6	1.65			
.129	3.09	.065	9,000	11,000	06
3.28	78.6	1.65			
.129	3.21	.065	8,600	10,000	/32
3.28	81.6	1.65			
.129	3.41	.065	7,900	9,300	07
3.28	86.6	1.65			
.129	3.80	.095	7,000	8,200	08
3.28	96.5	2.41			
.129	4.19	.095	6,300	7,400	09
3.28	106.5	2.41			
.129	4.59	.095	5,700	6,700	10
3.28	116.6	2.41			
.160	5.11	.109	5,200	6,100	11
4.06	129.7	2.77			
.160	5.50	.109	4,800	5,700	12
4.06	139.7	2.77			
.193	5.89	.109	4,400	5,200	13
4.90	149.7	2.77			
.193	6.29	.109	4,100	4,800	14
4.90	159.7	2.77			
.193	6.68	.109	3,800	4,500	15
4.90	169.7	2.77			
.224	7.20	.120	3,600	4,200	16
5.69	182.9	3.05			
.224	7.59	.120	3,400	4,000	17
5.69	192.9	3.05			
.224	7.99	.120	3,200	3,800	18
5.69	202.9	3.05			
.224	8.38	.120	3,000	3,500	19
5.69	212.9	3.05			
—	—	—	2,900	3,400	20
—	—	—	2,700	3,200	21
—	—	—	2,600	3,100	22

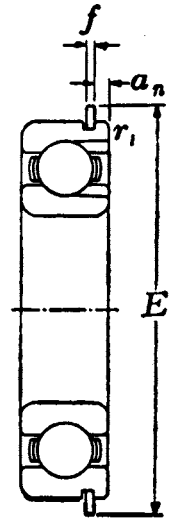

With Snap Ring
NR

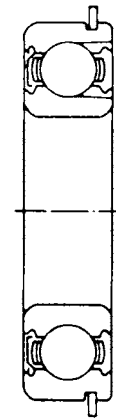

Single Shielded
With Snap Ring
ZNR



Units: INCHES
Millimeters

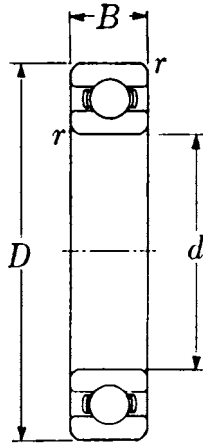

Open Type
TMB2



Single
Shielded
TMB2Z



Double
Shielded
TMB2ZZ

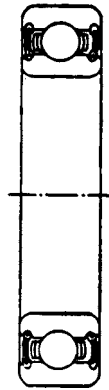

Double
Sealed
TMB2LLU
(Contact Type)



Double
Sealed
TMB2LLB
(Non-Contact Type)

SINGLE ROW RADIAL BALL BEARINGS

Bearing No.	Bore	O.D.	Width	Fillet Radii		Basic Load Ratings (lbs)		Weight (lbs)
	d	D	B	r	r ₁	Dynamic C	Static C ₀	
TMB200	.3937 10	1.1811 30	.3543 9	.024 .6	.020 .5	1,150	540	.071
TMB204	.7874 20	1.8504 47	.5512 14	.039 1	.020 .5	2,890	1,500	.234
TMB2/22	.8661 22	1.9685 50	.5512 14	.039 1	.020 .5	2,900	1,530	.258
TMB2/28	1.1024 28	2.2835 58	.6299 16	.039 1	.020 .5	4,000	2,190	.377
TMB206	1.1811 30	2.4409 62	.6299 16	.039 1	.020 .5	4,400	2,540	.439
TMB2/32	1.2598 32	2.5591 65	.6693 17	.039 1	.020 .5	4,650	2,610	.498
TMB207	1.3780 35	2.8346 72	.6693 17	.043 1.1	.020 .5	5,750	3,450	.635
TMB208	1.5748 40	3.1496 80	.7087 18	.043 1.1	.020 .5	6,550	4,000	.807
TMB209	1.7717 45	3.3465 85	.7480 19	.043 1.1	.020 .5	7,350	4,600	.897
TMB210	1.9685 50	3.5433 90	.7874 20	.043 1.1	.020 .5	7,900	5,200	1.02
TMB211	2.1654 55	3.9370 100	.8268 21	.059 1.5	.020 .5	9,750	6,550	1.34
TMB212	2.3622 60	4.3307 110	.8661 22	.059 1.5	.020 .5	11,800	8,150	1.73
TMB213	2.5591 65	4.7244 120	.9055 23	.059 1.5	.020 .5	12,900	9,000	2.18
TMB214	2.7559 70	4.9213 125	.9449 24	.059 1.5	.020 .5	14,000	9,900	2.36
TMB215	2.9528 75	5.1181 130	.9843 25	.059 1.5	.020 .5	14,900	11,100	2.60
TMB216	3.1496 80	5.5118 140	1.0236 26	.079 2.0	.020 .5	16,500	11,900	3.09
TMB217	3.3465 85	5.9055 150	1.1024 28	.079 2.0	.020 .5	18,700	14,300	3.95
TMB218	3.5433 90	6.2992 160	1.1811 30	.079 2.0	.020 .5	21,600	16,100	4.74
TMB219	3.7402 95	6.6929 170	1.2598 32	.079 2.0	.020 .5	24,500	18,400	5.78
TMB220	3.9370 100	7.0866 180	1.3386 34	.079 2.0	.020 .5	27,500	20,900	6.92

SINGLE ROW RADIAL BALL BEARINGS

Units: **INCHES**
Millimeters



Snap Ring Groove Dimensions			Snap Ring Dimensions			Limiting Speed (RPM)			Bore Diameter No.
D_n (max)	a_n (max)	b_n (min)	E (max)	f	e	Grease	Oil	LLU	
1.109	.081	.065	1.37	.042	.125	25,000	30,000	18,000	00
28.17	2.06	1.65	34.7	1.07	3.17				
1.756	.097	.065	2.07	.042	.156	16,000	18,000	10,000	04
44.60	2.46	1.65	52.7	1.07	3.96				
1.874	.097	.065	2.19	.042	.156	14,000	17,000	9,700	/22
47.60	2.46	1.65	55.7	1.07	3.96				
2.189	.097	.065	2.51	.042	.156	12,000	14,000	8,100	/28
55.60	2.46	1.65	63.7	1.07	3.96				
2.347	.129	.087	2.67	.065	.156	11,000	13,000	7,300	06
59.61	3.28	2.21	67.7	1.65	3.96				
2.465	.129	.087	2.78	.065	.156	11,000	12,000	7,100	/32
62.61	3.28	2.21	70.7	1.65	3.96				
2.709	.129	.087	3.09	.065	.188	9,800	11,000	6,300	07
68.81	3.28	2.21	78.6	1.65	4.77				
3.024	.129	.087	3.41	.065	.188	8,700	10,000	5,600	08
76.81	3.28	2.21	86.6	1.65	4.77				
3.221	.129	.087	3.61	.065	.188	7,800	9,200	5,200	09
81.81	3.28	2.21	91.6	1.65	4.77				
3.417	.129	.118	3.80	.095	.188	7,100	8,300	4,700	10
86.79	3.28	3.00	96.5	2.41	4.77				
3.811	.129	.118	4.19	.095	.188	6,400	7,600	4,300	11
96.80	3.28	3.00	106.5	2.41	4.77				
4.205	.129	.118	4.59	.095	.188	6,000	7,000	3,800	12
106.81	3.28	3.00	116.6	2.41	4.77				
4.536	.160	.134	5.11	.109	.281	5,500	6,500	3,600	13
115.21	4.06	3.40	129.7	2.77	7.13				
4.733	.160	.134	5.30	.109	.281	5,100	6,000	3,400	14
120.22	4.06	3.40	134.7	2.77	7.13				
4.930	.160	.134	5.50	.109	.281	4,800	5,600	3,200	15
125.22	4.06	3.40	139.7	2.77	7.13				
5.324	.193	.134	5.89	.109	.281	4,500	5,300	3,000	16
135.23	4.90	3.40	149.7	2.77	7.13				
5.718	.193	.134	6.29	.109	.281	4,200	5,000	2,800	17
145.24	4.90	3.40	159.7	2.77	7.13				
6.111	.193	.134	6.68	.109	.281	4,000	4,700	2,600	18
155.22	4.90	3.40	169.7	2.77	7.13				
6.443	.224	.150	7.20	.120	.375	3,700	4,400	2,500	19
163.65	5.69	3.81	182.9	3.05	9.52				
6.837	.224	.150	7.59	.120	.375	3,500	4,200	2,300	20
173.66	5.69	3.81	192.9	3.05	9.52				

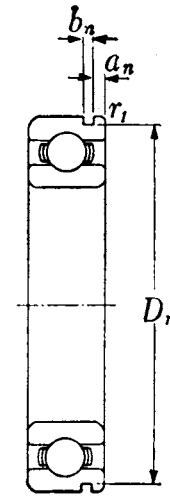

With Snap Ring Groove TMB2N

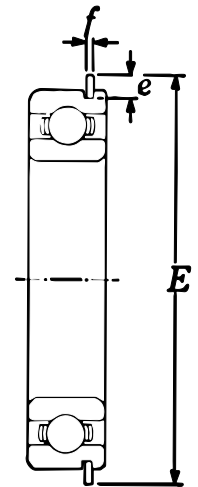

With Snap Ring TMB2NR



Single Shielded With Snap Ring TMB2ZNR



Units: INCHES
Millimeters

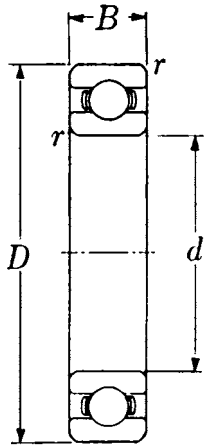

Open Type
TMB2



Single
Shielded
TMB2Z



Double
Shielded
TMB2ZZ

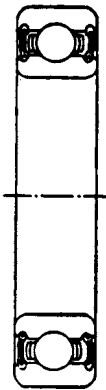

Double
Sealed
TMB2LLU
(Contact Type)



Double
Sealed
TMB2LLB
(Non-Contact Type)

SINGLE ROW RADIAL BALL BEARINGS

Bearing No.	Bore	O.D.	Width	Fillet Radii		Basic Load Ratings (lbs)		Weight (lbs)
	d	D	B	r	r ₁	Dynamic C	Static C ₀	
TMB221	4.1339 105	7.4803 190	1.4173 36	.083 2.1	.020 .5	29,900	23,500	8.16
TMB222	4.3307 110	7.8740 200	1.4961 38	.083 2.1	.020 .5	32,500	26,300	9.61
TMB224	4.7244 120	8.4646 215	1.5748 40	.083 2.1	—	35,000	29,500	11.4
TMB226	5.1181 130	9.0551 230	1.5748 40	.118 3.0	—	37,500	33,000	12.8
TMB228	5.5118 140	9.8425 250	1.6535 42	.118 3.0	—	37,500	33,500	16.5
TMB230	5.9055 150	10.6299 270	1.7717 45	.118 —	—	39,500	37,500	20.7
TMB232	6.2992 160	11.4173 290	1.8898 48	.118 —	—	41,500	42,000	31.5
TMB234	6.6929 170	12.2047 310	2.0472 52	.197 4.0	—	47,500	50,000	38.6
TMB236	7.0866 180	12.5984 320	2.0472 52	.197 4.0	—	51,000	54,000	40.3
TMB238	7.4803 190	13.3858 340	2.1654 55	.197 4.0	—	57,500	63,500	50.7
TMB240	7.8740 200	14.1732 360	2.2835 58	.197 4.0	—	60,800	70,000	62.2
TMB244	8.6614 220	15.7480 400	2.5590 65	.197 4.0	—	67,000	81,500	66.6

SINGLE ROW RADIAL BALL BEARINGS

Units: **INCHES**
Millimeters



Snap Ring Groove Dimensions			Snap Ring Dimensions			Limiting Speed (RPM)			Bore Diameter No.
D_n (max)	a_n (max)	b_n (min)	E (max)	f (max)	e	Grease	Oil	LU, LLU	
7.230	.224	.150	7.99	.120	.375	3,400	4,000	2,300	21
183.64	5.69	3.81	202.9	3.05	9.52				
7.624	.224	.150	8.38	.120	.375	3,200	3,800	2,200	22
193.65	5.69	3.81	212.9	3.05	9.52				
—	—	—	—	—	—	2,900	3,400	2,000	24
—	—	—	—	—	—	2,300	2,700	—	26
—	—	—	—	—	—	2,100	2,500	—	28
—	—	—	—	—	—	2,000	2,400	—	30
—	—	—	—	—	—	1,900	2,200	—	32
—	—	—	—	—	—	1,800	2,100	—	34
—	—	—	—	—	—	1,700	1,800	—	36
—	—	—	—	—	—	1,800	2,100	—	38
—	—	—	—	—	—	1,700	2,000	—	40
—	—	—	—	—	—	1,500	1,800	—	44

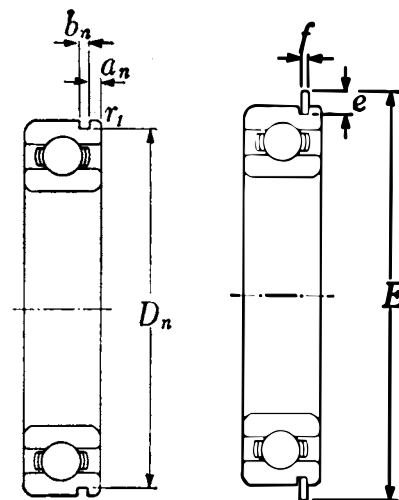

With Snap Ring Groove
TMB2N

With Snap Ring
TMB2NR

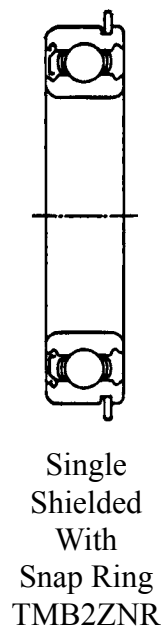

Single Shielded With Snap Ring
TMB2ZNR



Units: INCHES
Millimeters

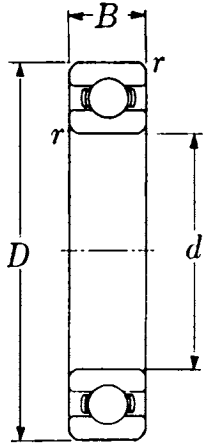

Open Type
TMB3

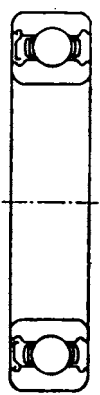

Single
Shielded
TMB3Z

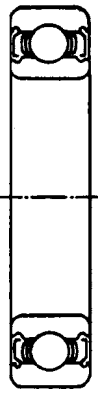

Double
Shielded
TMB3ZZ



Double
Sealed
TMB3LLU
(Contact Type)



Double
Sealed
TMB3LLB
(Non-Contact Type)

SINGLE ROW RADIAL BALL BEARINGS

Bearing No.	Bore	O.D.	Width	Fillet Radii		Basic Load Ratings (lbs)		Weight (lbs)
	d	D		r	r ₁	Dynamic C	Static C ₀	
TMB300	.3937 10	1.3780 35	.4331 11	.024 .6	.020 .5	1,840	785	.117
TMB301	.4724 12	1.4567 37	.4724 12	.039 1.0	.020 .5	2,180	940	.132
TMB302	.5906 15	1.6535 42	.5118 13	.039 1.0	.020 .5	2,570	1,220	.181
TMB303	.6693 17	1.8504 47	.5512 14	.039 1.0	.020 .5	3,050	1,470	.254
TMB304	.7874 20	2.0472 52	.5906 15	.043 1.1	.020 .5	3,600	1,770	.317
TMB3/22	.8661 22	2.2047 56	.6299 16	—	.020 .5	4,150	2,080	.388
TMB305	.9843 25	2.4409 62	.6693 17	.043 1.1	.020 .5	4,750	2,460	.511
TMB3/28	1.1024 28	2.6772 68	.7087 18	.043 1.1	.020 .5	6,000	3,150	.633
TMB306	1.1811 30	2.8346 72	.7480 19	.043 1.1	.020 .5	6,000	3,400	.763
TMB3/32	1.2598 32	2.9528 75	.7874 20	.043 1.1	.020 .5	6,700	3,800	.842
TMB307	1.3780 35	3.1496 80	.8268 21	.059 1.5	.020 .5	7,500	4,300	1.01
TMB308	1.5748 40	3.5433 90	.9055 23	.059 1.5	.020 .5	9,150	5,400	1.40
TMB309	1.7717 45	3.9370 100	.9843 25	.059 1.5	.020 .5	11,900	7,200	1.84
TMB310	1.9685 50	4.3307 110	1.0630 27	.079 2.0	.020 .5	13,900	8,600	2.36
TMB311	2.1654 55	4.7244 120	1.1417 29	.079 2.0	.020 .5	16,100	10,100	3.02
TMB312	2.3622 60	5.1181 130	1.2205 31	.083 2.1	.020 .5	18,400	11,700	3.75
TMB313	2.5591 65	5.5118 140	1.2992 33	.089 2.1	.020 .5	20,800	13,400	4.59
TMB314	2.7559 70	5.9055 150	1.3780 35	.083 2.1	.020 .5	23,400	15,300	5.56
TMB315	2.9528 75	6.2992 160	1.4567 37	.083 2.1	.020 .5	25,500	17,400	6.66
TMB316	3.1496 80	6.6929 170	1.5354 39	.083 2.1	.020 .5	27,600	19,500	7.91
TMB317	3.3465 85	7.0866 180	1.6142 41	.118 3.0	.020 .5	29,800	21,800	9.33
TMB318	3.5433 90	7.4803 190	1.6929 43	.118 3.0	.020 .5	32,000	24,100	10.8
TMB319	3.7402 95	7.8740 200	1.7717 45	.118 3.0	.020 .5	34,500	26,600	12.5
TMB320	3.9370 100	8.4646 215	1.8504 47	.118 3.0	—	39,000	31,500	15.4
TMB321	4.1339 105	8.8583 225	1.9291 49	.118 3.0	—	41,500	34,500	17.7
TMB322	4.3307 110	9.4488 240	1.9685 50	.118 3.0	—	46,000	40,500	21.0
TMB324	4.7244 120	10.2362 260	2.1654 55	.118 3.0	—	46,500	41,500	27.3
TMB326	5.1181 130	11.0236 280	2.2835 58	.157 4.0	—	51,500	48,000	33.3
TMB328	5.5118 140	11.8110 300	2.4409 62	.157 4.0	—	57,000	55,500	40.8
TMB330	5.9055 150	12.5984 320	2.5591 65	.157 4.0	—	61,500	63,500	57.8
TMB332	6.2992 160	13.3858 340	2.6772 68	.157 4.0	—	62,500	64,500	63.9
TMB334	6.6929 170	14.1732 360	2.8346 72	.157 4.0	—	73,500	80,000	76.1
TMB336	7.0866 180	14.9606 380	2.9528 75	.157 4.0	—	79,500	91,500	93.5
TMB338	7.4803 190	15.7480 400	3.0709 78	.197 5.0	—	79,500	93,000	108
TMB340	7.8740 200	16.5354 420	3.1496 80	.197 5.0	—	92,000	113,000	122
TMB344	8.6614 220	18.1102 460	3.4650 88	.197 5.0	—	92,500	116,000	134

SINGLE ROW RADIAL BALL BEARINGS

Units: **INCHES**
Millimeters



Snap Ring Groove Dimensions			Snap Ring Dimensions			Limiting Speed (RPM)			Bore Diameter No.
D_n (max)	a_n (max)	b_n (min)	E (max)	f (max)	e	Grease	Oil	LU, LLU	
1.306	.081	.065	1.56	.042	.125	23,000	27,000	16,000	00
33.17	2.06	1.65	39.7	1.07	3.18				
1.369	.081	.065	1.63	.042	.125	20,000	24,000	15,000	01
34.77	2.06	1.65	41.3	1.07	3.18				
1.565	.081	.065	1.82	.042	.125	17,000	21,000	12,000	02
39.75	2.06	1.65	46.3	1.07	3.18				
1.756	.097	.065	2.07	.042	.156	16,000	19,000	11,000	03
44.60	2.46	1.65	52.7	1.07	3.96				
1.958	.097	.065	2.28	.042	.156	14,000	17,000	10,000	04
49.73	2.46	1.65	57.9	1.07	3.96				
2.110	.097	.065	2.43	.042	.156	13,000	15,000	9,200	/22
53.59	2.46	1.65	61.7	1.07	3.96				
2.347	.129	.087	2.67	.065	.156	12,000	14,000	8,100	05
59.61	3.28	2.20	67.7	1.65	3.96				
2.552	.129	.087	2.94	.065	.188	11,000	13,000	7,400	/28
64.82	3.28	2.20	74.6	1.65	4.77				
2.709	.129	.087	3.09	.065	.188	10,000	12,000	6,600	06
68.81	3.28	2.20	78.6	1.65	4.77				
2.828	.129	.087	3.21	.065	.188	9,500	11,000	6,500	/32
71.83	3.28	2.20	81.6	1.65	4.77				
3.024	.129	.087	3.41	.065	.188	8,800	10,000	6,000	07
76.81	3.28	2.20	86.6	1.65	4.77				
3.417	.129	.118	3.80	.095	.188	7,800	9,200	5,300	08
86.79	3.28	3.00	96.5	2.41	4.77				
3.811	.129	.118	4.19	.095	.188	7,000	8,200	4,700	09
96.80	3.28	3.00	106.5	2.41	4.77				
4.205	.129	.118	4.59	.095	.188	6,400	7,500	4,200	10
106.81	3.28	3.00	116.6	2.41	4.77				
4.536	.160	.134	5.11	.109	.281	5,800	6,800	3,900	11
115.21	4.06	3.40	129.7	2.77	7.13				
4.930	.160	.134	5.50	.109	.281	5,400	6,300	3,600	12
125.22	4.06	3.40	139.7	2.77	7.13				
5.324	.193	.134	5.89	.109	.281	4,900	5,800	3,300	13
135.23	4.90	3.40	149.7	2.77	7.13				
5.718	.193	.134	6.29	.109	.281	4,600	5,400	3,100	14
145.24	4.90	3.40	159.7	2.77	7.13				
6.111	.193	.134	6.68	.109	.281	4,300	5,000	2,900	15
155.22	4.90	3.40	169.7	2.77	7.13				
6.443	.224	.150	7.20	.120	.375	4,000	4,700	2,700	16
163.65	5.69	3.80	182.9	3.05	9.52				
6.837	.224	.150	7.59	.120	.375	3,800	4,500	2,600	17
173.66	5.69	3.80	192.9	3.05	9.52				
7.230	.224	.150	7.99	.120	.375	3,600	4,200	2,400	18
183.64	5.69	3.80	202.9	3.05	9.52				
7.624	.224	.150	8.38	.120	.375	3,300	3,900	2,300	19
193.65	5.69	3.80	212.9	3.05	9.52				
—	—	—	—	—	—	3,200	3,700	2,200	20
—	—	—	—	—	—	3,000	3,600	2,100	21
—	—	—	—	—	—	2,900	3,400	1,900	22
—	—	—	—	—	—	2,600	3,100	—	24
—	—	—	—	—	—	2,400	2,800	—	26
—	—	—	—	—	—	2,200	2,600	—	28
—	—	—	—	—	—	2,100	2,400	—	30
—	—	—	—	—	—	1,900	2,300	—	32
—	—	—	—	—	—	1,800	2,100	—	34
—	—	—	—	—	—	1,700	2,000	—	36
—	—	—	—	—	—	1,600	1,900	—	38
—	—	—	—	—	—	1,500	1,800	—	40
—	—	—	—	—	—	1,400	1,600	—	44

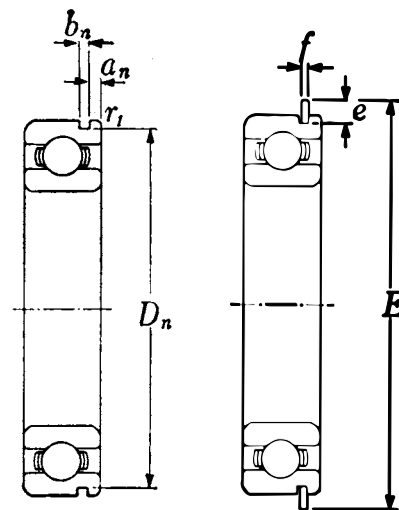

With Snap Ring Groove TMB3N

With Snap Ring TMB3NR



Single Shielded With Snap Ring TMB3ZNR

Notes

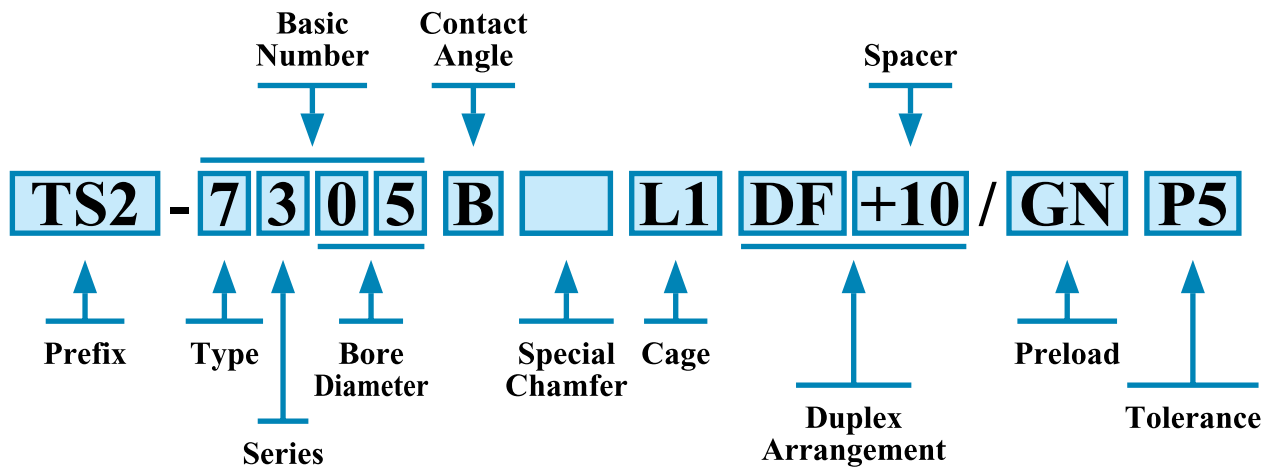

1. PREFIX

TS2:	Heat stabilization for up to 320°F (160°C)
TS3:	Heat stabilization for up to 390°F (200°C)
TS4:	Heat stabilization for up to 480°F (250°C)
5S:	Ceramic Rolling Elements

2. TYPE

32,33:	Double row angular contact ball bearings with filling slot
52,53:	Double row angular contact ball bearings without filling slot
70,72,73:	Angular contact ball bearings
BNT:	High speed angular contact ball bearings
HSB:	High speed angular contact ball bearings
SF:	Special single row angular contact ball bearings
DE & DF:	Special double row angular contact ball bearings

3. CONTACT ANGLE

No Symbol:	Contact Angle 30°
B:	Contact angle 40°
C:	Contact angle 15°

4. CHAMFER

Xn:	Special chamfer, from 1 onward (X1, X2 ...)
-----	---

5. CAGE

No Symbol:	Standard cage
J:	Pressed steel cage
L1:	Machined brass cage
T1:	Phenolic cage
T2:	Plastic cage, nylon or teflon

6. DUPLEX ARRANGEMENT

DB:	Duplex pair, back to back mounting
DF:	Duplex pair, face to face mounting
DT:	Duplex pair, tandem mounting
G:	Single bearings, flush ground universal mount for DB, DF and DT arrangement
GD2:	Pair of universally mountable bearings
+A:	Spacer (A is nominal width of spacer in mm)

7. PRELOAD

GL:	Light preload
GN:	Normal preload
GM:	Medium preload
GH:	Heavy preload
Gn:	Special preload

8. TOLERANCE

P6:	ISO class 6 (equivalent to ABEC 3)
P5:	ISO class 5 (equivalent to ABEC 5)
P4:	ISO class 4 (equivalent to ABEC 7)
PXn:	Special Tolerance, from 1 onward (PX1, PX2 ...)



Units: INCHES
Millimeters

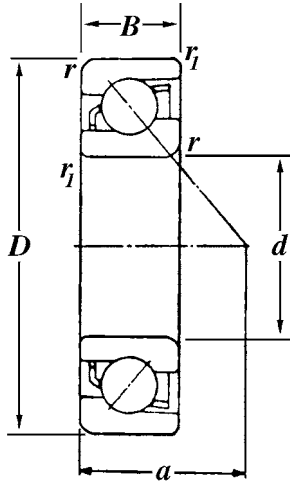

40°
Contact Angle
72B

SINGLE ROW ANGULAR CONTACT BALL BEARINGS

Bearing No.	Bore <i>d</i>	O.D. <i>D</i>	Width <i>B</i>	Fillet Radius		Load Center <i>a</i>	Basic Load Ratings (lbs)		Limiting Speeds (rpm)		Weight (lbs)	Limiting Speeds (rpm)	
				<i>r</i>	<i>r1</i>		Dynamic <i>C</i>	Static <i>Co</i>	Grease	Oil		Grease	Oil
												Duplex: DB, DF, DT	
7200B	0.3937 10	1.1811 30	0.3543 9	0.024 0.6	0.012 0.3	0.51 13	1,120	565	24,000	32,000	0.064	19,000	26,000
7201B	0.4724 12	1.2598 32	0.3937 10	0.024 0.6	0.012 0.3	0.55 14	1,480	750	21,000	28,000	0.079	17,000	23,000
7202B	0.5906 15	1.3780 35	0.4331 11	0.024 0.6	0.012 0.3	0.63 16	1,880	980	18,000	25,000	0.101	15,000	20,000
7203B	0.6693 17	1.5748 40	0.4724 12	0.024 0.6	0.012 0.3	0.72 18	2,480	1,370	17,000	22,000	0.146	13,000	18,000
7204B	0.7874 20	1.8504 47	0.5512 14	0.039 1.0	0.024 0.6	0.85 21.5	2,990	1,730	15,000	20,000	0.225	12,000	16,000
7205B	0.9843 25	2.0472 52	0.5906 15	0.039 1.0	0.024 0.6	0.94 24	3,300	2,120	12,000	16,000	0.284	10,000	13,000
7206B	1.1811 30	2.4409 62	0.6299 16	0.039 1.0	0.024 0.6	1.08 27.5	4,600	3,050	11,000	14,000	0.434	8,600	11,000
7207B	1.3780 35	2.8346 72	0.6693 17	0.043 1.1	0.024 0.6	1.22 31	6,100	4,150	9,300	12,000	0.633	7,500	10,000
7208B	1.5748 40	3.1496 80	0.7087 18	0.043 1.1	0.024 0.6	1.34 34	7,200	5,150	8,300	11,000	0.827	6,700	8,900
7209B	1.7717 45	3.3465 85	0.7480 19	0.043 1.1	0.024 0.6	1.46 37	8,100	5,900	7,400	9,900	0.904	6,000	8,000
7210B	1.9685 50	3.5433 90	0.7874 20	0.043 1.1	0.024 0.6	1.56 39.5	8,400	6,450	6,700	9,000	1.03	5,500	7,300
7211B	2.1654 55	3.9370 100	0.8268 21	0.059 1.5	0.039 1.0	1.69 43	10,400	8,100	6,100	8,200	1.35	5,000	6,600
7212B	2.3622 60	4.3307 110	0.8661 22	0.059 1.5	0.039 1.0	1.87 47.5	12,600	10,000	5,700	7,600	1.72	4,600	6,100
7213B	2.5591 65	4.7244 120	0.9055 23	0.059 1.5	0.039 1.0	1.99 50.5	14,300	11,800	5,200	7,000	2.16	4,200	5,600
7214B	2.7559 70	4.9213 125	0.9449 24	0.059 1.5	0.039 1.0	2.09 53	15,500	13,000	4,900	6,500	2.45	3,900	5,200
7215B	2.9528 75	5.1181 130	0.9843 25	0.059 1.5	0.039 1.0	2.20 56	16,000	14,000	4,500	6,000	2.62	3,700	4,900
7216B	3.1496 80	5.5118 140	1.0236 26	0.079 2	0.039 1.0	2.32 59	18,100	15,600	4,300	5,700	3.13	3,400	4,600
7217B	3.3465 85	5.9055 150	1.1024 28	0.079 2	0.039 1.0	2.50 63.5	20,200	18,100	4,000	5,300	4.01	3,200	4,300
7218B	3.5433 90	6.2992 160	1.1811 30	0.098 2.5	0.039 1.0	2.66 67.5	24,000	21,100	3,800	5,000	4.89	3,100	4,100
7219B	3.7402 95	6.6929 170	1.2598 32	0.083 2.1	0.059 1.5	2.81 71.5	27,200	24,200	3,500	4,700	6.00	2,900	3,800
7220B	3.9370 100	7.0866 180	1.3386 34	0.083 2.1	0.059 1.5	2.99 76	29,300	25,700	3,400	4,500	7.19	2,700	3,600
7221B	4.1339 105	7.4803 190	1.4173 36	0.083 2.1	0.059 1.5	3.15 80	32,000	29,000	3,200	4,300	8.53	2,600	3,500
7222B	4.3307 110	7.8740 200	1.4961 38	0.083 2.1	0.059 1.5	3.31 84	34,500	32,500	3,000	4,000	10.0	2,500	3,300
7224B	4.7244 120	8.4646 215	1.5748 40	0.083 2.1	0.059 1.5	3.56 90.5	37,000	36,500	2,800	3,700	13.8	2,300	3,000
7226B	5.1181 130	9.0551 230	1.5748 40	0.118 3	0.059 1.5	3.76 95.5	40,000	40,500	2,500	3,400	15.8	2,100	2,700
7228B	5.5118 140	9.8425 250	1.6535 42	0.118 3	0.059 1.5	4.06 103	41,000	44,000	2,300	3,100	19.4	1,900	2,500
7230B	5.9055 150	10.6299 270	1.7717 45	0.118 3	0.059 1.5	4.37 111	47,000	53,000	2,200	2,900	24.3	1,800	2,400
7232B	6.2992 160	11.4173 290	1.8898 48	0.118 3	0.059 1.5	4.65 118	53,500	62,500	2,000	2,700	30.2	1,600	2,200
7234B	6.6929 170	12.2047 310	2.0472 52	0.157 4	0.059 1.5	5.00 127	60,000	73,500	1,900	2,500	37.5	1,500	2,100
7236B	7.0866 180	12.5984 320	2.0472 52	0.157 4	0.059 1.5	5.16 131	62,000	78,500	1,800	2,400	39.0	1,400	1,900
7238B	7.4803 190	13.3858 340	2.1654 55	0.157 4	0.059 1.5	5.47 139	61,500	79,500	1,700	2,200	47.0	1,400	1,800
7240B	7.8740 200	14.1732 360	2.2835 58	0.157 4	0.059 1.5	5.75 146	68,500	91,500	1,600	2,100	55.8	1,300	1,700

SINGLE ROW ANGULAR CONTACT BALL BEARINGS

Units: INCHES
Millimeters



Bearing No.	Bore <i>d</i>	O.D. <i>D</i>	Width <i>B</i>	Fillet Radius		Load Center <i>a</i>	Basic Load Ratings (lbs)		Limiting Speeds (rpm)		Weight (lbs)	Limiting Speeds (rpm)	
				<i>r</i>	<i>r₁</i>		Dynamic <i>C</i>	Static <i>C₀</i>	Grease	Oil		Grease	Oil
7300B	0.3937 10	1.3780 35	0.4331 11	0.024 0.6	0.020 0.3	0.59 15	2,140	1,040	22,000	29,000	0.090	18,000	24,000
7301B	0.4724 12	1.4567 37	0.4724 12	0.039 1	0.024 0.6	0.6496 16.5	2,370	1,110	19,000	26,000	0.099	16,000	21,000
7302B	0.5906 15	1.6535 42	0.5118 13	0.039 1	0.024 0.6	0.7480 19	2,810	1,500	17,000	22,000	0.126	13,000	18,000
7303B	0.6693 17	1.8504 47	0.5512 14	0.039 1	0.024 0.6	0.81 20.5	3,350	1,800	15,000	20,000	0.240	12,000	16,000
7304B	0.7874 20	2.0472 52	0.5906 15	0.043 1.1	0.024 0.6	0.89 22.5	3,900	2,170	13,000	18,000	0.311	11,000	14,000
7305B	0.9843 25	2.4409 62	0.6693 17	0.043 1.1	0.024 0.6	1.06 27	5,500	3,300	11,000	15,000	0.516	9,100	12,000
7306B	1.1811 30	2.8346 72	0.7480 19	0.043 1.1	0.024 0.6	1.24 31.5	6,950	4,600	9,600	13,000	0.776	7,700	10,000
7307B	1.3780 35	3.1496 80	0.8268 21	0.059 1.5	0.039 1	1.36 34.5	8,250	5,450	8,400	11,000	1.03	6,800	9,000
7308B	1.5748 40	3.5433 90	0.9055 23	0.059 1.5	0.039 1	1.54 39	10,100	6,800	7,400	9,900	1.40	6,000	8,000
7309B	1.7717 45	3.9370 100	0.9843 25	0.059 1.5	0.039 1	1.69 43	13,100	9,050	6,600	8,900	1.88	5,400	7,200
7310B	1.9685 50	4.3307 110	1.0630 27	0.079 2	0.039 1	1.85 47	15,300	10,800	6,000	8,100	2.45	4,900	6,500
7311B	2.1654 55	4.7244 120	1.1417 29	0.079 2	0.039 1	2.05 52	17,700	12,800	5,500	7,300	3.13	4,500	5,900
7312B	2.3622 60	5.1181 130	1.2205 31	0.083 2.1	0.043 1.1	2.20 56	20,200	14,800	5,100	6,800	3.90	4,100	5,500
7313B	2.5591 65	5.5118 140	1.2992 33	0.083 2.1	0.043 1.1	2.34 59.5	22,900	17,000	4,700	6,300	4.72	3,800	5,100
7314B	2.7559 70	5.9055 150	1.3780 35	0.083 2.1	0.043 1.1	2.50 63.5	25,700	19,300	4,400	5,800	5.75	3,500	4,700
7315B	2.9528 75	6.2992 160	1.4567 37	0.083 2.1	0.043 1.1	2.68 68	28,000	21,900	4,100	5,400	6.90	3,300	4,400
7316B	3.1496 80	6.6929 170	1.5354 39	0.083 2.1	0.043 1.1	2.83 72	30,500	24,600	3,800	5,100	8.20	3,100	4,100
7317B	3.3465 85	7.0866 180	1.6142 41	0.118 3	0.043 1.1	2.99 76	32,500	27,400	3,600	4,800	9.77	2,900	3,900
7318B	3.5433 90	7.4803 190	1.6929 43	0.118 3	0.043 1.1	3.17 80.5	35,000	30,500	3,400	4,500	11.4	2,700	3,700
7319B	3.7402 95	7.8740 200	1.7717 45	0.118 3	0.043 1.1	3.33 84.5	37,500	33,500	3,200	4,200	13.2	2,600	3,400
7320B	3.9370 100	8.4646 215	1.8504 47	0.118 3	0.043 1.1	3.52 89.5	43,000	40,000	3,000	4,000	16.1	2,400	3,300
7321B	4.1339 105	8.8583 225	1.9291 49	0.118 3	0.043 1.1	3.68 93.5	45,500	43,500	2,900	3,800	18.4	2,300	3,100
7322B	4.3307 110	9.4488 240	1.9685 50	0.118 3	0.043 1.1	3.90 99	51,000	51,000	2,700	3,700	21.6	2,200	3,000
7324B	4.7244 120	10.2362 260	2.1654 55	0.157 4	0.043 1.1	4.21 107	50,500	52,000	2,500	3,300	32.4	2,000	2,700
7326B	5.1181 130	11.0236 280	2.2835 58	0.157 4	0.059 1.5	4.53 115	56,000	60,500	2,300	3,100	38.8	1,900	2,500
7328B	5.5118 140	11.8110 300	2.4409 62	0.157 4	0.059 1.5	4.84 123	62,000	69,500	2,100	2,800	47.4	1,700	2,300
7330B	5.9055 150	12.5984 320	2.5591 65	0.157 4	0.059 1.5	5.16 131	67,500	79,000	2,000	2,600	55.3	1,600	2,100
7332B	6.2992 160	13.3858 340	2.6772 68	0.157 4	0.059 1.5	5.47 139	71,000	87,000	1,800	2,400	65.7	1,500	2,000
7334B	6.6929 170	14.1732 360	2.8346 72	0.157 4	0.059 1.5	5.79 147	80,000	100,000	1,700	2,300	77.8	1,400	1,800
7336B	7.0866 180	14.9606 380	2.9528 75	0.157 4	0.059 1.5	6.10 155	84,000	110,000	1,600	2,100	90.2	1,300	1,700
7338B	7.4803 190	15.7480 400	3.0709 78	0.197 5	0.079 2	6.42 163	87,500	120,000	1,500	2,000	104	1,200	1,600
7340B	7.8740 200	16.5354 420	3.1496 80	0.197 5	0.079 2	6.69 170	92,000	125,000	1,400	1,900	117	1,200	1,500

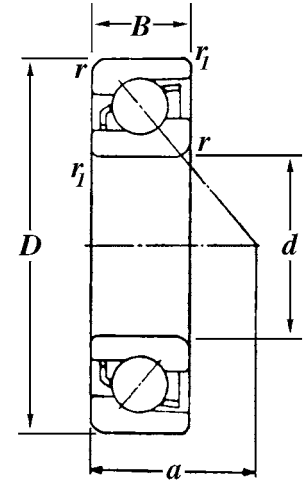

40°
Contact Angle
73B



Units: INCHES
Millimeters

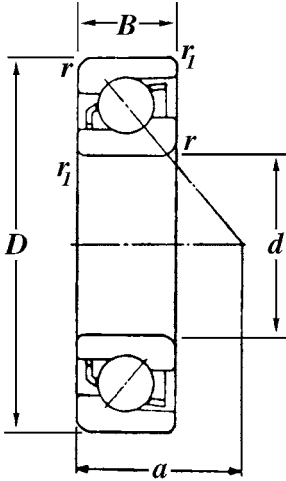

40°
Contact Angle
74B

Bearing No.	Bore	O.D.	Width	Fillet Radius		Load Center a	Basic Load Ratings (lbs)		Weight (lbs)
	d	D	B	r	r ₁		Dynamic C	Static C ₀	
7404B	.7874 20	2.8346 72	.7480 19	.043 1.1	.024 .6	1.14 29	6,850	3,650	1.00
7406B	1.1811 30	3.5433 90	.9843 25	.039 1	.024 .6	1.46 37	9,100	5,450	1.83
7407B	1.3780 35	3.9370 100	.9843 25	.039 1	.024 .6	1.61 41	11,600	7,350	2.45
7408B	1.5748 40	4.3307 110	1.0630 27	.059 1.5	.024 .6	1.77 45	13,600	8,500	3.09
7409B	1.7717 45	4.7244 120	1.1417 29	.059 1.5	.024 .6	1.95 49.5	16,800	11,100	3.94
7410B	1.9685 50	5.1181 130	1.2205 31	.083 2.1	.043 1.1	2.11 53.5	19,100	12,800	4.87
7411B	2.1654 55	5.5118 140	1.2992 33	.083 2.1	.043 1.1	2.26 57.5	20,300	13,900	6.02
7412B	2.3622 60	5.9055 150	1.3780 35	.083 2.1	.043 1.1	2.44 62	22,800	15,900	7.25
7413B	2.5591 65	6.2992 160	1.4567 37	.083 2.1	.043 1.1	2.60 66	26,500	19,800	8.77
7414B	2.7559 70	7.0866 180	1.6535 42	.098 2.5	.043 1.1	2.89 73.5	31,000	24,900	12.7
7415B	2.9528 75	7.4803 190	1.7717 45	.098 2.5	.043 1.1	3.09 78.5	33,500	27,000	15.0
7416B	3.1496 80	7.8740 200	1.8898 48	.098 2.5	.043 1.1	3.27 83	35,500	29,800	17.5
7417B	3.3465 85	8.2677 210	2.0472 52	.118 3	.039 1	3.46 88	39,500	33,500	20.4
7418B	3.5433 90	8.8583 225	2.1260 54	.118 3	.039 1	3.68 93.5	45,000	44,000	24.9

SINGLE ROW ANGULAR CONTACT BALL BEARINGS

Units: INCHES
Millimeters



Bearing No.	Bore <i>d</i>	O.D. <i>D</i>	Width <i>B</i>	Fillet Radius		Load Center <i>a</i>	Basic Load Ratings (lbs)		Limiting Speeds (rpm)		Weight (lbs)	Limiting Speeds (rpm)	
				<i>r</i>	<i>r</i> ₁		Dynamic <i>C</i>	Static <i>C</i> ₀	Grease	Oil		Grease	Oil
7000	0.3937 10	1.0236 26	0.3150 8	0.012 0.3	0.006 0.15	0.35 9.0	1,040	465	29,000	39,000	0.049	23,000	31,000
7001	0.4724 12	1.1024 28	0.3150 8	0.012 0.3	0.006 0.15	0.39 10.0	1,140	555	26,000	35,000	0.053	21,000	28,000
7002	0.5906 15	1.2598 32	0.3543 9	0.012 0.3	0.006 0.15	0.45 11.5	1,300	705	23,000	31,000	0.077	18,000	24,000
7003	0.6693 17	1.3780 35	0.3937 10	0.012 0.3	0.006 0.15	0.49 12.5	1,610	860	21,000	28,000	0.099	17,000	22,000
7004	0.7874 20	1.6535 42	0.4724 12	0.024 0.6	0.012 0.3	0.59 15.0	2,180	1,260	19,000	25,000	0.174	15,000	20,000
7005	0.9843 25	1.8504 47	0.4724 12	0.024 0.6	0.012 0.3	0.65 16.5	2,420	1,540	16,000	21,000	0.201	12,000	17,000
7006	1.1811 30	2.1654 55	0.5118 13	0.039 1	0.024 0.6	0.75 19.0	3,100	2,130	13,000	18,000	0.293	11,000	14,000
7007	1.3780 35	2.4409 62	0.5512 14	0.039 1	0.024 0.6	0.83 21.0	3,950	2,830	12,000	16,000	0.403	9,400	13,000
7008	1.5748 40	2.6772 68	0.5906 15	0.039 1	0.024 0.6	0.91 23.0	4,200	3,300	10,000	14,000	0.481	8,300	11,000
7009	1.7717 45	2.9528 75	0.6299 16	0.039 1	0.024 0.6	1.00 25.5	5,000	3,950	9,500	13,000	0.613	7,500	10,000
7010	1.9685 50	3.1496 80	0.6299 16	0.039 1	0.024 0.6	1.06 27.0	5,300	4,500	8,600	11,000	0.677	6,800	9,100
7011	2.1654 55	3.5433 90	0.7087 18	0.043 1.1	0.024 0.6	1.18 30.0	7,000	5,900	7,900	11,000	0.924	6,300	8,400
7012	2.3622 60	3.7402 95	0.7087 18	0.043 1.1	0.024 0.6	1.24 31.5	7,150	6,300	7,200	9,600	0.990	5,800	7,700
7013	2.5591 65	3.9370 100	0.7087 18	0.043 1.1	0.024 0.6	1.30 33.0	7,600	7,050	6,700	9,000	1.05	5,400	7,100
7014	2.7559 70	4.3307 110	0.7874 20	0.043 1.1	0.024 0.6	1.42 36.0	9,600	8,850	6,200	8,300	1.58	5,000	6,600
7015	2.9528 75	4.5276 115	0.7874 20	0.043 1.1	0.024 0.6	1.48 37.5	9,800	9,400	5,800	7,800	1.67	4,600	6,200
7016	3.1496 80	4.9213 125	0.8661 22	0.043 1.1	0.024 0.6	1.59 40.5	12,000	11,400	5,500	7,300	2.16	4,400	5,800
7017	3.3465 85	5.1181 130	0.8661 22	0.043 1.1	0.024 0.6	1.65 42.0	12,300	12,000	5,100	6,900	2.43	4,100	5,500
7018	3.5433 90	5.5118 140	0.9449 24	0.059 1.5	0.039 1	1.77 45.0	14,700	14,200	4,900	6,500	3.09	3,900	5,200
7019	3.7402 95	5.7087 145	0.9449 24	0.059 1.5	0.039 1	1.83 46.5	15,000	15,000	4,600	6,100	3.26	3,700	4,900
7020	3.9370 100	5.9055 150	0.9449 24	0.059 1.5	0.039 1	1.89 48.0	15,400	15,900	4,400	5,800	3.35	3,500	4,600
7021	4.1339 105	6.2992 160	1.0236 26	0.079 2	0.039 1	2.03 51.5	18,000	18,400	4,100	5,500	4.21	3,300	4,400
7022	4.3307 110	6.6929 170	1.1024 28	0.079 2	0.039 1	2.15 54.5	20,600	20,900	3,900	5,300	5.29	3,100	4,200
7024	4.7244 120	7.0866 180	1.1024 28	0.079 2	0.039 1	2.26 57.5	21,100	22,200	3,600	4,800	5.73	2,900	3,800
7026	5.1181 130	7.8740 200	1.2992 33	0.079 2	0.039 1	2.52 64.0	26,400	28,200	3,300	4,400	8.64	2,600	3,500
7028	5.5118 140	8.2677 210	1.2992 33	0.079 2	0.039 1	2.64 67.0	26,900	29,800	3,100	4,100	9.17	2,400	3,300
7030	5.9055 150	8.8583 225	1.3780 35	0.083 2.1	0.043 1.1	2.81 71.5	31,000	34,500	2,800	3,800	10.7	2,300	3,000
7032	6.2992 160	9.4488 240	1.4961 38	0.083 2.1	0.043 1.1	3.03 77.0	35,000	39,500	2,700	3,600	13.0	2,100	2,800
7034	6.6929 170	10.2362 260	1.6535 42	0.083 2.1	0.043 1.1	3.27 83.0	42,000	48,000	2,500	3,300	17.4	2,000	2,600
7036	7.0866 180	11.0236 280	1.8110 46	0.083 2.1	0.043 1.1	3.52 89.5	49,000	59,500	2,300	3,100	22.0	1,900	2,500
7038	7.4803 190	11.4173 290	1.8110 46	0.083 2.1	0.043 1.1	3.64 92.5	50,500	63,000	2,200	2,900	23.6	1,800	2,300
7040	7.8740 200	12.2047 310	2.0079 51	0.083 2.1	0.043 1.1	3.90 99.0	56,500	73,000	2,100	2,800	30.4	1,700	2,200

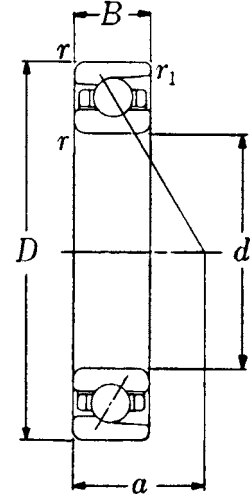

30°
Contact Angle



Units: INCHES
Millimeters

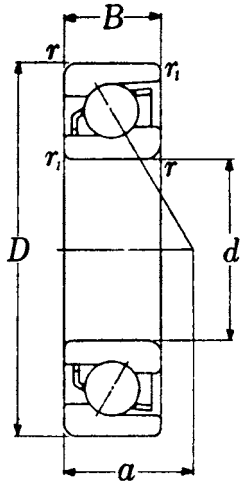

30°
Contact Angle
72

SINGLE ROW ANGULAR CONTACT BALL BEARINGS

Bearing No.	Bore <i>d</i>	O.D. <i>D</i>	Width <i>B</i>	Fillet Radius		Load Center <i>a</i>	Basic Load Ratings (lbs)		Limiting Speeds (rpm)		Weight (lbs)	Limiting Speeds (rpm)	
				<i>r</i>	<i>r1</i>		Dynamic <i>C</i>	Static <i>Co</i>	Grease	Oil		Grease	Oil
7200	0.3937 10	1.1811 30	0.3543 9	0.024 0.6	0.012 0.3	0.41 10.5	1,220	615	28,000	37,000	0.064	22,000	30,000
7201	0.4724 12	1.2598 32	0.3937 10	0.024 0.6	0.012 0.3	0.45 11.5	1,600	810	25,000	33,000	0.077	20,000	26,000
7202	0.5906 15	1.3780 35	0.4331 11	0.024 0.6	0.012 0.3	0.49 12.5	2,040	1,060	22,000	29,000	0.101	17,000	23,000
7203	0.6693 17	1.5748 40	0.4724 12	0.024 0.6	0.012 0.3	0.57 14.5	2,690	1,490	19,000	26,000	0.141	15,000	21,000
7204	0.7874 20	1.8504 47	0.5512 14	0.039 1	0.024 0.6	0.67 17	3,250	1,890	17,000	23,000	0.220	14,000	18,000
7205	0.9843 25	2.0472 52	0.5906 15	0.039 1	0.024 0.6	0.75 19	3,650	2,320	14,000	19,000	0.276	11,000	15,000
7206	1.1811 30	2.4409 62	0.6299 16	0.039 1	0.024 0.6	0.85 21.5	5,050	3,350	12,000	16,000	0.425	9,800	13,000
7207	1.3780 35	2.8346 72	0.6693 17	0.043 1.1	0.024 0.6	0.94 24	6,700	4,500	11,000	14,000	0.619	8,600	11,000
7208	1.5748 40	3.1496 80	0.7087 18	0.043 1.1	0.024 0.6	1.04 26.5	7,950	5,650	9,600	13,000	0.783	7,700	10,000
7209	1.7717 45	3.3465 85	0.7480 19	0.043 1.1	0.024 0.6	1.12 28.5	8,900	6,450	8,700	12,000	0.891	6,900	9,200
7210	1.9685 50	3.5433 90	0.7874 20	0.043 1.1	0.024 0.6	1.18 30	9,300	7,050	7,900	10,000	1.01	6,300	8,300
7211	2.1654 55	3.9370 100	0.8268 21	0.059 1.5	0.039 1	1.30 33	11,500	8,900	7,100	9,500	1.32	5,700	7,600
7212	2.3622 60	4.3307 110	0.8661 22	0.059 1.5	0.039 1	1.42 36	13,900	11,000	6,600	8,800	1.69	5,300	7,000
7213	2.5591 65	4.7244 120	0.9055 23	0.059 1.5	0.039 1	1.50 38	15,800	13,000	6,100	8,100	2.12	4,900	6,500
7214	2.7559 70	4.9213 125	0.9449 24	0.059 1.5	0.039 1	1.57 40	17,200	14,300	5,700	7,600	2.40	4,500	6,000
7215	2.9528 75	5.1181 130	0.9843 25	0.059 1.5	0.039 1	1.67 42.5	17,800	15,400	5,300	7,100	2.58	4,200	5,600
7216	3.1496 80	5.5118 140	1.0236 26	0.079 2	0.039 1	1.77 45	20,000	17,100	5,000	6,600	3.06	3,900	5,300
7217	3.3465 85	5.9055 150	1.1024 28	0.079 2	0.039 1	1.89 48	22,400	19,900	4,700	6,200	3.92	3,700	5,000
7218	3.5433 90	6.2992 160	1.1811 30	0.079 2	0.039 1	2.01 51	26,500	23,200	4,400	5,900	4.81	3,500	4,700
7219	3.7402 95	6.6929 170	1.2598 32	0.083 2.1	0.043 1.1	2.15 54.5	30,000	26,500	4,100	5,500	5.89	3,300	4,400
7220	3.9370 100	7.0866 180	1.3386 34	0.083 2.1	0.043 1.1	2.26 57.5	32,500	28,200	3,900	5,200	7.05	3,100	4,200
7221	4.1339 105	7.4803 190	1.4173 36	0.083 2.1	0.043 1.1	2.38 60.5	35,000	32,000	3,700	5,000	8.36	3,000	4,000
7222	4.3307 110	7.8740 200	1.4961 38	0.083 2.1	0.043 1.1	2.52 64	38,000	35,500	3,500	4,700	9.81	2,800	3,800
7224	4.7244 120	8.4646 215	1.5748 40	0.083 2.1	0.043 1.1	2.70 68.5	41,000	40,000	3,200	4,300	13.8	2,600	3,400
7226	5.1181 130	9.0551 230	1.5748 40	0.118 3	0.043 1.1	2.83 72	44,000	44,500	3,000	4,000	15.8	2,400	3,100
7228	5.5118 140	9.8425 250	1.6535 42	0.118 3	0.043 1.1	3.05 77.5	45,500	48,500	2,700	3,600	19.4	2,200	2,900
7230	5.9055 150	10.6299 270	1.7717 45	0.118 3	0.043 1.1	3.27 83	52,000	58,000	2,500	3,400	24.3	2,000	2,700
7232	6.2992 160	11.4173 290	1.8898 48	0.118 3	0.043 1.1	3.50 89	59,000	69,000	2,400	3,200	30.2	1,900	2,500
7234	6.6929 170	12.2047 310	2.0472 52	0.157 4	0.059 1.5	3.76 95.5	66,000	80,500	2,200	3,000	37.5	1,800	2,400
7236	7.0866 180	12.5984 320	2.0472 52	0.157 4	0.059 1.5	3.86 98	68,500	86,500	2,100	2,800	39.0	1,700	2,200
7238	7.4803 190	13.3858 340	2.1654 55	0.157 4	0.059 1.5	4.09 104	68,000	87,500	2,000	2,600	47.0	1,600	2,100
7240	7.8740 200	14.1732 360	2.2835 58	0.157 4	0.059 1.5	4.33 110	76,000	101,000	1,900	2,500	55.8	1,500	2,000

SINGLE ROW ANGULAR CONTACT BALL BEARINGS

Units: INCHES
Millimeters



Bearing No.	Bore <i>d</i>	O.D. <i>D</i>	Width <i>B</i>	Fillet Radius		Load Center <i>a</i>	Basic Load Ratings (lbs)		Limiting Speeds (rpm)		Weight (lbs)	Limiting Speeds (rpm)	
				<i>r</i>	<i>r₁</i>		Dynamic <i>C</i>	Static <i>C₀</i>	Grease	Oil		Grease	Oil
7300	0.3937 10 35	1.3780 35 11	0.4331 11 0.6	0.024 0.6 0.3	0.012 0.3 12	0.47 12	2,280	11,100	26,000	34,000	0.088	20,000	27,000
7301	0.4724 12 37	1.4567 37 12	0.4724 12 1	0.039 1 0.6	0.024 1 0.6	0.5118 13	2,510	1,180	23,000	30,000	0.097	18,000	24,000
7302	0.5906 15 42	1.6535 42 13	0.5118 13 1	0.039 1 0.6	0.024 1 0.6	0.5906 15	3,000	1,620	19,000	26,000	0.121	15,000	21,000
7303	0.6693 17 47	1.8504 47 14	0.5512 14 1	0.039 1 0.6	0.024 1 0.6	0.63 16	3,600	1,940	18,000	24,000	0.236	14,000	19,000
7304	0.7874 20 52	2.0472 52 15	0.5906 15 1.1	0.043 1.1 0.6	0.024 1.1 0.6	0.71 18	4,200	2,340	16,000	21,000	0.304	12,000	17,000
7305	0.9843 25 62	2.4409 62 17	0.6693 17 1.1	0.043 1.1 0.6	0.024 1.1 0.6	0.83 21	5,950	3,550	13,000	17,000	0.507	10,000	14,000
7306	1.1811 30 72	2.8346 72 19	0.7480 19 1.1	0.043 1.1 0.6	0.024 1.1 0.6	0.96 24.5	7,550	5,000	11,000	15,000	0.761	8,900	12,000
7307	1.3780 35 80	3.1496 80 21	0.8268 21 1.5	0.059 1.5 1	0.039 1 0.6	1.06 27	9,000	5,900	9,800	13,000	1.02	7,800	10,000
7308	1.5748 40 90	3.5433 90 23	0.9055 23 1.5	0.059 1.5 1	0.039 1 0.6	1.20 30.5	11,000	7,400	8,600	12,000	1.38	6,900	9,200
7309	1.7717 45 100	3.9370 100 25	0.9843 25 1.5	0.059 1.5 1	0.039 1 0.6	1.32 33.5	14,300	9,800	7,800	10,000	1.85	6,200	8,200
7310	1.9685 50 110	4.3307 110 27	1.0630 27 2	0.079 2 1	0.039 1 0.6	1.44 36.5	16,700	11,700	7,100	9,400	2.40	5,600	7,500
7311	2.1654 55 120	4.7244 120 29	1.1417 29 2	0.079 2 1	0.039 1 0.6	1.57 40	19,300	13,900	6,400	8,600	3.06	5,100	6,800
7312	2.3622 60 130	5.1181 130 31	1.2205 31 2.1	0.083 2.1 1.5	0.059 1.5 1	1.69 43	22,000	16,100	5,900	7,900	3.84	4,700	6,300
7313	2.5591 65 140	5.5118 140 33	1.2992 33 2.1	0.083 2.1 1.5	0.059 1.5 1	1.81 46	25,000	18,400	5,500	7,300	4.65	4,400	5,800
7314	2.7559 70 150	5.9055 150 35	1.3780 35 2.1	0.083 2.1 1.5	0.059 1.5 1	1.95 49.5	28,000	21,000	5,100	6,800	5.64	4,100	5,400
7315	2.9528 75 160	6.2992 160 37	1.4567 37 2.1	0.083 2.1 1.5	0.059 1.5 1	2.07 52.5	30,500	23,800	4,800	6,300	6.77	3,800	5,000
7316	3.1496 80 170	6.6929 170 39	1.5354 39 2.1	0.083 2.1 1.5	0.059 1.5 1	2.19 55.5	33,000	26,700	4,500	5,900	8.05	3,500	4,700
7317	3.3465 85 180	7.0866 180 41	1.6142 41 3	0.118 3 1.5	0.059 1.5 1	2.32 59	35,500	29,800	4,200	5,600	9.57	3,300	4,500
7318	3.5433 90 190	7.4803 190 43	1.6929 43 3	0.118 3 1.5	0.059 1.5 1	2.44 62	38,500	33,000	4,000	5,300	11.2	3,200	4,200
7319	3.7402 95 200	7.8740 200 45	1.7717 45 3	0.118 3 1.5	0.059 1.5 1	2.56 65	41,000	36,500	3,700	5,000	13.0	3,000	3,900
7320	3.9370 100 215	8.4646 215 47	1.8504 47 3	0.118 3 1.5	0.059 1.5 1	2.72 69	46,500	43,500	3,500	4,700	15.8	2,800	3,700
7321	4.1339 105 225	8.8583 225 49	1.9291 49 3	0.118 3 1.5	0.059 1.5 1	2.83 72	49,500	47,500	3,400	4,500	18.1	2,700	3,600
7322	4.3307 110 240	9.4488 240 50	1.9685 50 3	0.118 3 1.5	0.059 1.5 1	2.99 76	52,000	50,500	3,200	4,300	21.2	2,600	3,400
7324	4.7244 120 260	10.2362 260 55	2.1654 55 3	0.118 3 1.5	0.059 1.5 1	3.25 82.5	55,500	56,500	2,900	3,900	32.4	2,300	3,100
7326	5.1181 130 280	11.0236 280 58	2.2835 58 4	0.157 4 1.5	0.059 1.5 1	3.46 88	61,500	66,000	2,700	3,600	38.8	2,100	2,800
7328	5.5118 140 300	11.8110 300 62	2.4409 62 4	0.157 4 1.5	0.059 1.5 1	3.72 94.5	67,500	75,500	2,500	3,300	47.4	2,000	2,600
7330	5.9055 150 320	12.5984 320 65	2.5591 65 4	0.157 4 1.5	0.059 1.5 1	3.94 100	74,000	86,000	2,300	3,100	55.3	1,800	2,400
7332	6.2992 160 340	13.3858 340 68	2.6772 68 4	0.157 4 1.5	0.059 1.5 1	4.17 106	78,000	95,000	2,100	2,800	65.7	1,700	2,300
7334	6.6929 170 360	14.1732 360 72	2.8346 72 4	0.157 4 1.5	0.059 1.5 1	4.45 113	87,500	109,000	2,000	2,700	77.8	1,600	2,100
7336	7.0866 180 380	14.9606 380 75	2.9528 75 4	0.157 4 1.5	0.059 1.5 1	4.65 118	92,000	120,000	1,900	2,500	90.2	1,500	2,000
7338	7.4803 190 400	15.7480 400 78	3.0709 78 5	0.197 5 1.5	0.059 1.5 1	4.88 124	96,500	131,000	1,800	2,300	104	1,400	1,900
7340	7.8740 200 420	16.5354 420 80	3.1496 80 5	0.197 5 1.5	0.059 1.5 1	5.12 130	101,000	137,000	1,700	2,200	117	1,300	1,800

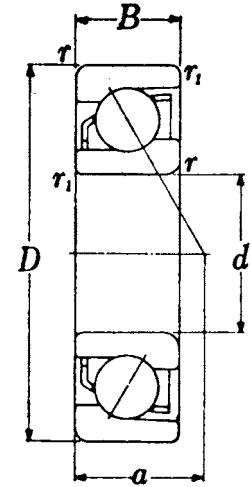

30°
Contact Angle
73



**SERIES
70C**

**High
Precision
Grade**

Suffix P5

- AFBMA RBEC 5 •
- ISO Class 5 •

Suffix P4

- AFBMA ABEC 7 •
- ISO Class 4 •

Suffix P2

- AFBMA ABEC 9 •
- ISO Class 2 •

Units: **INCHES**
Millimeters

SINGLE ROW ANGULAR CONTACT BALL BEARINGS

Bearing No.	Bore <i>d</i>	O.D. <i>D</i>	Width <i>B</i>	Fillet Radius		Load Center <i>a</i>	Basic Load Ratings (lbs)		Limiting Speeds (rpm)		Weight (lbs)	Limiting Speeds (rpm)	
				<i>r</i>	<i>r1</i>		Dynamic <i>C</i>	Static <i>Co</i>	Grease	Oil		Grease	Oil
7000C	0.3937 10	1.0236 26	0.3150 8	0.012 0.3	0.15 0.06	0.26 6.5	1,790	990	43,000	58,000	0.042	34,000	46,000
7001C	0.4724 12	1.1024 28	0.3150 8	0.012 0.3	0.15 0.06	0.26 6.5	1,220	595	39,000	52,000	0.046	31,000	41,000
7002C	0.5906 15	1.2598 32	0.3543 9	0.012 0.3	0.15 0.06	0.30 7.5	1,400	760	32,000	42,000	0.064	27,000	36,000
7003C	0.6693 17	1.3780 35	0.3937 10	0.012 0.3	0.15 0.06	0.33 8.5	1,740	925	31,000	41,000	0.084	24,000	33,000
7004C	0.7874 20	1.6535 42	0.4724 12	0.024 0.6	0.012 0.3	0.39 10.0	2,360	1,360	27,000	36,000	0.146	22,000	29,000
7005C	0.9843 25	1.8504 47	0.4724 12	0.024 0.6	0.012 0.3	0.43 11.0	2,630	1,670	23,000	31,000	0.132	18,000	24,000
7006C	1.1811 30	2.1654 55	0.5118 13	0.039 1.0	0.024 0.6	0.49 12.5	3,400	2,310	20,000	26,000	0.196	16,000	21,000
7007C	1.3780 35	2.4409 62	0.5512 14	0.039 1.0	0.024 0.6	0.53 13.5	4,300	3,050	17,000	23,000	0.287	14,000	18,000
7008C	1.5748 40	2.6772 68	0.5906 15	0.039 1.0	0.024 0.6	0.57 14.5	4,600	3,550	15,000	21,000	0.357	12,000	16,000
7009C	1.7717 45	2.9528 75	0.6299 16	0.039 1.0	0.024 0.6	0.63 16.0	5,500	4,350	14,000	19,000	0.461	11,000	15,000
7010C	1.9685 50	3.1496 80	0.6299 16	0.039 1.0	0.024 0.6	0.65 16.5	5,850	4,900	13,000	17,000	0.514	10,000	13,000
7011C	2.1654 55	3.5433 90	0.7087 18	0.043 1.1	0.024 0.6	0.73 18.5	7,650	6,450	12,000	15,000	0.712	9,200	12,000
7012C	2.3622 60	3.7402 95	0.7087 18	0.043 1.1	0.024 0.6	0.77 19.5	7,900	6,900	11,000	14,000	0.772	8,400	11,000
7013C	2.5591 65	3.9370 100	0.7087 18	0.043 1.1	0.024 0.6	0.79 20.0	8,350	7,700	9,900	13,000	0.840	7,800	10,000
7014C	2.7559 70	4.3307 110	0.7874 20	0.043 1.1	0.024 0.6	0.87 22.0	10,500	9,650	9,200	12,000	1.28	7,300	9,700
7015C	2.9528 75	4.5276 115	0.7874 20	0.043 1.1	0.024 0.6	0.89 22.5	10,800	10,300	8,600	11,000	1.33	6,800	9,000
7016C	3.1496 80	4.9213 125	0.8661 22	0.043 1.1	0.024 0.6	0.96 24.5	13,200	12,400	8,000	11,000	1.72	6,400	8,500
7017C	3.3465 85	5.1181 130	0.8661 22	0.043 1.1	0.024 0.6	1.00 25.5	13,500	13,200	7,600	10,000	1.94	6,000	8,000
7018C	3.5433 90	5.5118 140	0.9449 24	0.059 1.5	0.039 1.0	1.08 27.5	16,100	15,500	7,100	9,500	2.47	5,700	7,500
7019C	3.7402 95	5.7087 145	0.9449 24	0.059 1.5	0.039 1.0	1.10 28.0	16,500	16,500	6,800	9,000	2.60	5,400	7,100
7020C	3.9370 100	5.9055 150	0.9449 24	0.059 1.5	0.039 1.0	1.12 28.5	16,900	17,400	6,400	8,600	2.69	5,100	6,800
7021C	4.1339 105	6.2992 160	1.0236 26	0.079 2.0	0.039 1.0	1.22 31.0	19,800	20,100	6,100	8,100	3.37	4,800	6,400
7022C	4.3307 110	6.6929 170	1.1024 28	0.079 2.0	0.039 1.0	1.30 33.0	22,700	22,800	5,800	7,700	4.23	4,600	6,100
7024C	4.7244 120	7.0866 180	1.1024 28	0.079 2.0	0.039 1.0	1.34 34.0	23,200	24,300	5,300	7,100	4.74	4,200	5,600
7026C	5.1181 130	7.8740 200	1.2992 33	0.079 2.0	0.039 1.0	1.52 38.5	29,000	31,000	4,900	6,500	7.14	3,800	5,100
7028C	5.5118 140	8.2677 210	1.2992 33	0.079 2.0	0.039 1.0	1.57 40.0	29,700	32,500	4,500	6,000	7.58	3,600	4,800
7030C	5.9055 150	8.8583 225	1.3780 35	0.083 2.1	0.043 1.1	1.67 42.5	34,000	38,000	4,200	5,600	10.7	3,300	4,400
7032C	6.2992 160	9.4488 240	1.4961 38	0.083 2.1	0.043 1.1	1.81 46.0	38,500	43,500	3,900	5,200	13.0	3,100	4,100
7034C	6.6929 170	10.2362 260	1.6535 42	0.083 2.1	0.043 1.1	1.97 50.0	46,000	52,500	3,700	4,900	17.4	2,900	3,900
7036C	7.0866 180	11.0236 280	1.8110 46	0.083 2.1	0.043 1.1	2.13 54.0	54,000	65,500	3,400	4,600	22.0	2,700	3,600
7038C	7.4803 190	11.4173 290	1.8110 46	0.083 2.1	0.043 1.1	2.17 55.0	55,500	69,000	3,200	4,300	23.6	2,600	3,400
7040C	7.8740 200	12.2047 310	2.0079 51	0.083 2.1	0.043 1.1	2.34 59.5	62,000	80,000	3,100	4,100	30.4	2,400	3,200

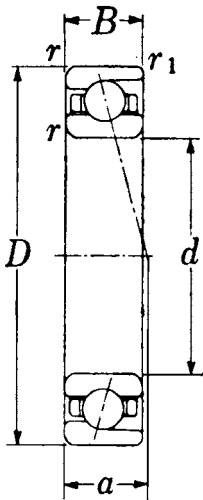

15°
Contact
Angle

SINGLE ROW ANGULAR CONTACT BALL BEARINGS

Units: **INCHES**
Millimeters



**SERIES
72C
High
Precision
Grade**

Suffix P5
• AFBMA RBEC 5 •
• ISO Class 5 •

Suffix P4
• AFBMA ABEC 7 •
• ISO Class 4 •

Suffix P2
• AFBMA ABEC 9 •
• ISO Class 2 •

Bearing No.	Bore <i>d</i>	O.D. <i>D</i>	Width <i>B</i>	Fillet Radius		Load Center <i>a</i>	Basic Load Ratings (lbs)		Limiting Speeds (rpm)		Weight (lbs)	Limiting Speeds (rpm)	
				<i>r</i>	<i>r1</i>		Dynamic <i>C</i>	Static <i>Co</i>	Grease	Oil		Grease	Oil
7200C	0.3937 10	1.1811 30	0.3543 9	0.024 0.6	0.012 0.3	0.28 7.0	1,220	595	41,000	55,000	0.037	32,000	43,000
7201C	0.4724 12	1.2598 32	0.3937 10	0.024 0.6	0.012 0.3	0.31 8.0	1,590	780	36,000	49,000	0.049	29,000	38,000
7202C	0.5906 15	1.3780 35	0.4331 11	0.024 0.6	0.012 0.3	0.35 9.0	2,020	1,010	32,000	42,000	0.068	25,000	33,000
7203C	0.6693 17	1.5748 40	0.4724 12	0.024 0.6	0.012 0.3	0.39 10.0	2,510	1,310	29,000	38,000	0.106	23,000	30,000
7204C	0.7874 20	1.8504 47	0.5512 14	0.039 1.0	0.024 0.6	0.45 11.5	3,300	1,840	25,000	34,000	0.181	20,000	27,000
7205C	0.9843 25	2.0472 52	0.5906 15	0.039 1.0	0.024 0.6	0.49 12.5	3,750	2,300	21,000	28,000	0.249	17,000	22,000
7206C	1.1811 30	2.4409 62	0.6299 16	0.039 1.0	0.024 0.6	0.55 14.0	5,200	3,300	18,000	24,000	0.395	14,000	19,000
7207C	1.3780 35	2.8346 72	0.6693 17	0.043 1.1	0.024 0.6	0.61 15.5	6,850	4,500	16,000	21,000	0.578	13,000	17,000
7208C	1.5748 40	3.1496 80	0.7087 18	0.043 1.1	0.024 0.6	0.67 17.0	8,150	5,650	14,000	19,000	0.752	11,000	15,000
7209C	1.7717 45	3.3465 85	0.7480 19	0.043 1.1	0.024 0.6	0.71 18.0	9,200	6,500	14,000	19,000	0.858	10,000	13,000
7210C	1.9685 50	3.5433 90	0.7874 20	0.043 1.1	0.024 0.6	0.77 19.5	9,650	7,150	12,000	15,000	0.963	9,100	12,000
7211C	2.1654 55	3.9370 100	0.8268 21	0.059 1.5	0.039 1.0	0.83 21.0	11,900	9,000	11,000	14,000	1.27	8,300	11,000
7212C	2.3622 60	4.3307 110	0.8661 22	0.059 1.5	0.039 1.0	0.89 22.5	14,400	11,100	9,700	13,000	1.66	7,700	10,000
7213C	2.5591 65	4.7244 120	0.9055 23	0.059 1.5	0.039 1.0	0.94 24.0	15,700	12,300	9,000	12,000	2.07	7,100	9,500
7214C	2.7559 70	4.9213 125	0.9449 24	0.059 1.5	0.039 1.0	0.98 25.0	17,100	13,500	8,300	11,000	2.34	6,600	8,800
7215C	2.9528 75	5.1181 130	0.9843 25	0.059 1.5	0.039 1.0	1.04 26.5	17,800	14,700	7,800	10,000	2.56	6,200	8,200
7216C	3.1496 80	5.5118 140	1.0236 26	0.079 2.0	0.039 1.0	1.08 27.5	20,900	17,400	7,300	9,700	3.04	5,800	7,700
7217C	3.3465 85	5.9055 150	1.1024 28	0.079 2.0	0.039 1.0	1.18 30.0	23,400	20,300	6,900	9,100	3.88	5,400	7,200
7218C	3.5433 90	6.2992 160	1.1811 30	0.079 2.0	0.039 1.0	1.24 31.5	27,600	23,500	6,500	8,600	4.76	5,100	6,800
7219C	3.7402 95	6.6929 170	1.2598 32	0.083 2.1	0.043 1.1	1.34 34.0	31,000	26,900	6,100	8,100	5.82	4,800	6,400
7220C	3.9370 100	7.0866 180	1.3386 34	0.083 2.1	0.043 1.1	1.42 36.0	33,500	28,500	5,800	7,700	6.99	4,600	6,100
7221C	4.1339 105	7.4803 190	1.4173 36	0.083 2.1	0.043 1.1	1.50 38.0	36,500	32,000	5,500	7,300	8.27	4,400	5,800
7222C	4.3307 110	7.8740 200	1.4961 38	0.083 2.1	0.043 1.1	1.57 40.0	39,500	36,000	5,200	6,900	9.72	4,100	5,500

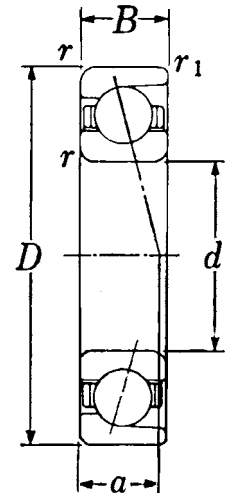

15°
Contact
Angle

NTN

**SERIES
73C**

**High
Precision
Grade**

Suffix P5

- AFBMA RBEC 5 •
- ISO Class 5 •

Suffix P4

- AFBMA ABEC 7 •
- ISO Class 4 •

Suffix P2

- AFBMA ABEC 9 •
- ISO Class 2 •

Units: **INCHES**
Millimeters

SINGLE ROW ANGULAR CONTACT BALL BEARINGS

Bearing No.	Bore <i>d</i>	O.D. <i>D</i>	Width <i>B</i>	Fillet Radius		Load Center <i>a</i>	Basic Load Ratings (lbs)		Limiting Speeds (rpm)		Weight (lbs)	Limiting Speeds (rpm)	
				<i>r</i>	<i>r1</i>		Dynamic <i>C</i>	Static <i>Co</i>	Grease	Oil		Grease	Oil
7302C	0.5906 15	1.6535 42	0.5118 13	0.039 1	0.024 0.6	0.41 10.5	2,990	1,540	28,000	38,000	0.130	23,000	30,000
7303C	0.6693 17	1.8504 47	0.5512 14	0.039 1	0.024 0.6	0.45 11.5	3,550	1,860	26,000	35,000	0.190	21,000	27,000
7304C	0.7874 20	2.0472 52	0.5906 15	0.043 1.1	0.024 0.6	0.49 12.5	1,450	2,240	23,000	31,000	0.260	18,000	24,000
7305C	0.9843 25	2.4409 62	0.6693 17	0.043 1.1	0.024 0.6	0.57 14.5	5,950	3,450	19,000	26,000	0.445	15,000	20,000
7306C	1.1811 30	2.8346 72	0.7480 19	0.043 1.1	0.024 0.6	0.65 16.5	7,250	4,550	16,000	22,000	0.690	13,000	17,000
7307C	1.3780 35	3.1496 80	0.8268 21	0.059 1.5	0.039 1.0	0.71 18.0	9,050	5,800	14,000	19,000	0.939	11,000	15,000
7308C	1.5748 40	3.5433 90	0.9055 23	0.059 1.5	0.039 1.0	0.79 20.0	11,100	7,250	13,000	17,000	1.36	10,000	13,000
7309C	1.7717 45	3.9370 100	0.9843 25	0.059 1.5	0.039 1.0	0.89 22.5	14,400	9,700	11,000	15,000	1.82	9,000	12,000
7310C	1.9685 50	4.3307 110	1.0630 27	0.079 2	0.039 1.0	0.96 24.5	16,900	11,600	10,000	14,000	2.31	8,200	11,000
7311C	2.1654 55	4.7244 120	1.1417 29	0.079 2	0.039 1.0	1.04 26.5	19,500	13,600	94,000	13,000	2.93	7,500	9,900
7312C	2.3622 60	5.1181 130	1.2205 31	0.083 2.1	0.043 1.1	1.12 28.5	22,300	15,800	8,700	12,000	3.70	6,900	9,200
7313C	2.5591 65	5.5118 140	1.2992 33	0.083 2.1	0.043 1.1	1.18 30.0	25,200	18,100	8,100	11,000	4.52	6,400	8,500
7314C	2.7559 70	5.9055 150	1.3780 35	0.083 2.1	0.043 1.1	1.26 32.0	28,400	20,700	7,500	10,000	5.47	5,900	7,900
7315C	2.9528 75	6.2992 160	1.4567 37	0.083 2.1	0.043 1.1	1.34 34.0	31,000	23,400	7,000	9,300	6.79	5,500	7,400
7316C	3.1496 80	6.6929 170	1.5354 39	0.083 2.1	0.043 1.1	1.42 36.0	33,500	26,200	6,500	8,700	8.14	5,200	6,900
7317C	3.3465 85	7.0866 180	1.6142 41	0.118 3.0	0.043 1.1	1.52 38.5	36,000	29,300	6,200	8,200	9.44	4,900	6,500
7318C	3.5433 90	7.4803 190	1.6929 43	0.118 3.0	0.043 1.1	1.59 40.5	41,000	35,500	5,800	7,800	11.0	4,600	6,100
7319C	3.7402 95	7.8740 200	1.7717 45	0.118 3.0	0.043 1.1	1.67 42.5	44,000	39,000	5,500	7,300	12.9	4,300	5,800
7320C	3.9370 100	8.4646 215	1.8504 47	0.118 3.0	0.043 1.1	1.75 44.5	50,000	46,500	5,200	6,900	15.7	4,100	5,500
7321C	4.1339 105	8.8583 225	1.9291 49	0.118 3.0	0.043 1.1	1.83 46.5	53,000	50,500	5,500	7,300	17.9	3,900	5,200
7322C	4.3307 110	9.4488 240	1.9685 50	0.118 3.0	0.043 1.1	1.91 48.5	56,000	54,500	4,700	6,300	20.9	3,700	5,000

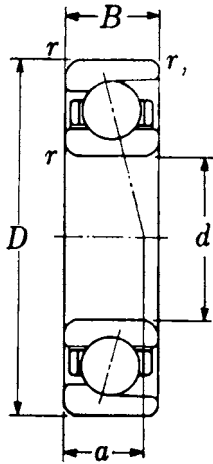

15°
Contact
Angle

ANGULAR CONTACT BALL BEARINGS

Units: INCHES
Millimeters



**SERIES
BNT0
HSB0C**
High Speed
Service

Suffix P5
• AFBMA RBEC 5 •
• ISO Class 5 •
Suffix P4
• AFBMA ABEC 7 •
• ISO Class 4 •
Suffix P2
• AFBMA ABEC 9 •
• ISO Class 2 •

Bearing No.	Bore <i>d</i>	O.D. <i>D</i>	Width <i>B</i>	Fillet Radius		Load Center <i>a</i>	Basic Load Ratings (lbs)		Limiting Speeds (rpm)		Weight (lbs)
				<i>r</i>	<i>r_l</i>		Dynamic <i>C</i>	Static <i>C₀</i>	Grease	Oil	
BNT000	0.3937 10	1.0236 26	0.3150 8	0.012 0.3	0.006 0.15	0.26 6.5	845	325	48,000	64,000	0.037
BNT001	0.4724 12	1.1024 28	0.3150 8	0.012 0.3	0.006 0.15	0.26 6.5	930	390	43,000	57,000	0.043
BNT002	0.5906 15	1.2598 32	0.3543 9	0.012 0.3	0.006 0.15	0.30 7.5	1,070	500	38,000	50,000	0.063
BNT003	0.6693 17	1.3780 35	0.3937 10	0.012 0.3	0.006 0.15	0.33 8.5	1,330	605	34,000	46,000	0.083
BNT004	0.7874 20	1.6535 42	0.4724 12	0.024 0.6	0.012 0.3	0.39 10.0	1,800	890	30,000	40,000	0.145
BNT005	0.9843 25	1.8504 47	0.4724 12	0.024 0.6	0.012 0.3	0.43 11.0	2,010	1,090	25,000	34,000	0.171
BNT006	1.1811 30	2.1654 55	0.5118 13	0.039 1.0	0.024 0.6	0.49 12.5	2,600	1,510	22,000	29,000	0.265
BNT007	1.3780 35	2.4409 62	0.5512 14	0.039 1.0	0.024 0.6	0.53 13.5	3,300	2,010	19,000	26,000	0.372
BNT008	1.5748 40	2.6772 68	0.5906 15	0.039 1.0	0.024 0.6	0.57 14.5	3,550	2,340	17,000	23,000	0.464
BNT009	1.7717 45	2.9528 75	0.6299 16	0.039 1.0	0.024 0.6	0.63 16.0	4,200	2,830	15,000	21,000	0.600
HSB010C	1.9685 50	3.1496 80	0.6299 16	0.039 1.0	0.024 0.6	0.65 16.5	4,680	2,565	14,000	19,000	0.564
HSB011C	2.1654 55	3.5433 90	0.7087 18	0.043 1.1	0.024 0.6	0.73 18.5	5,085	3,060	13,000	17,000	0.875
HSB012C	2.3622 60	3.7402 95	0.7087 18	0.043 1.1	0.024 0.6	0.77 19.5	5,332	3,375	12,000	16,000	0.937
HSB013C	2.5591 65	3.9370 100	0.7087 18	0.043 1.1	0.024 0.6	0.79 20.0	5,400	3,555	11,000	15,000	0.997
HSB014C	2.7559 70	4.3307 110	0.7874 20	0.043 1.1	0.024 0.6	0.87 22.0	6,615	4,477	10,000	14,000	1.41
HSB015C	2.9528 75	4.5276 115	0.7874 20	0.043 1.1	0.024 0.6	0.89 22.5	7,087	5,040	9,500	13,000	1.50
HSB016C	3.1496 80	4.9213 125	0.8661 22	0.043 1.1	0.024 0.6	0.96 24.5	8,100	5,782	8,900	12,000	2.02
HSB017C	3.3465 85	5.1181 130	0.8661 22	0.043 1.1	0.024 0.6	1.00 25.5	8,212	6,030	8,400	11,000	2.11
HSB018C	3.5433 90	5.5118 140	0.9449 24	0.059 1.5	0.039 1.0	1.08 27.5	9,450	7,087	7,900	11,000	2.76
HSB019C	3.7402 95	5.7087 145	0.9449 24	0.059 1.5	0.039 1.0	1.10 28.0	9,562	7,312	7,500	10,000	2.87
HSB020C	3.9370 100	5.9055 150	0.9449 24	0.059 1.5	0.039 1.0	1.12 28.5	9,900	7,875	7,100	9,500	3.00
HSB021C	4.1339 105	6.2992 160	1.0236 26	0.079 2	0.039 1.0	1.22 31	11,400	9,100	6,700	9,000	3.81
HSB022C	4.3307 110	6.6929 170	1.1024 28	0.079 2	0.039 1.0	1.30 33	14,100	11,100	6,400	8,600	4.70
HSB024C	4.7244 120	7.0866 180	1.1024 28	0.079 2	0.039 1.0	1.34 34	14,200	11,600	5,900	7,900	5.03
HSB026C	5.1181 130	7.8740 200	1.2992 33	0.079 2	0.039 1.0	1.52 38.5	20,300	16,000	5,400	7,200	7.50
HSB028C	5.5118 140	8.2677 210	1.2992 33	0.079 2	0.039 1.0	1.57 40	21,000	17,300	5,000	6,700	8.11
HSB030C	5.9055 150	8.8583 225	1.3780 35	0.083 2.1	0.043 1.1	1.67 42.5	21,700	18,700	4,600	6,200	9.83
HSB032C	6.2992 160	9.4488 240	1.4961 38	0.083 2.1	0.043 1.1	1.81 46	25,400	21,800	4,300	5,800	12.0
HSB034C	6.6929 170	10.2362 260	1.6535 42	0.083 2.1	0.043 1.1	1.97 50	29,000	25,000	4,100	5,400	16.3

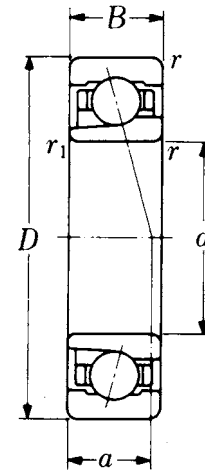

15°
Contact
Angle

NTN
SERIES
32
33
MAXIMUM
TYPE

Units: **INCHES**
 Millimeters

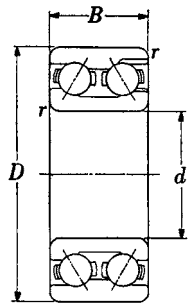

32

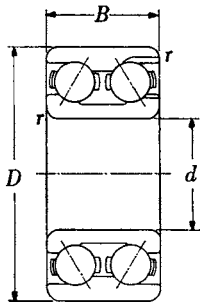

33

DOUBLE ROW ANGULAR CONTACT BALL BEARINGS

Bearing No.	Bore <i>d</i>	O.D. <i>D</i>	Width <i>B</i>	Fillet Radius <i>r</i>	Basic Load Ratings (lbs)		Limiting Speeds (rpm)		Weight (lbs)
					Dynamic <i>C</i>	Static <i>C₀</i>	Grease	Oil	
3200	0.3937 10	1.1811 30	0.5625 14.29	0.024 0.6	1,890	1,460	14,000	19,000	0.112
3201	0.4724 12	1.2598 32	0.6250 15.88	0.024 0.6	1,900	1,510	13,000	17,000	0.132
3202	0.5906 15	1.3780 35	0.6250 15.88	0.024 0.6	2,500	2,040	11,000	15,000	0.152
3203	0.6693 17	1.5748 40	0.6875 17.46	0.024 0.6	3,200	2,660	9,900	13,000	0.218
3204	0.7874 20	1.8504 47	0.8125 20.64	0.039 1	3,950	3,400	8,800	12,000	0.366
3205	0.9843 25	2.0472 52	0.8125 20.64	0.039 1	4,350	4,150	7,300	9,800	0.403
3206	1.1811 30	2.4409 62	0.9375 23.81	0.039 1	6,250	6,150	6,300	8,400	0.668
3207	1.3780 35	2.8346 72	1.0625 26.99	0.043 1.1	8,400	8,550	5,500	7,400	1.01
3208	1.5748 40	3.1496 80	1.1875 30.16	0.043 1.1	9,100	10,100	4,900	6,600	1.38
3209	1.7717 45	3.3465 85	1.1875 30.16	0.043 1.1	10,400	11,700	4,400	5,900	1.49
3210	1.9685 50	3.5433 90	1.1875 30.16	0.043 1.1	11,800	13,400	4,000	5,300	1.54
3211	2.1654 55	3.9370 100	1.3125 33.34	0.059 1.5	14,800	17,200	3,600	4,900	2.36
3212	2.3622 60	4.3307 110	1.4375 36.51	0.059 1.5	15,800	19,800	3,400	4,500	2.95
3213	2.5591 65	4.7244 120	1.5000 38.10	0.059 1.5	17,500	22,300	3,100	4,200	3.70
3214	2.7559 70	4.9213 125	1.5625 39.69	0.059 1.5	19,300	24,800	2,900	3,900	4.06
3215	2.9528 75	5.1181 130	1.6250 41.28	0.059 1.5	21,100	27,500	2,700	3,600	4.43
3216	3.1496 80	5.5118 140	1.7500 44.45	0.079 2	23,300	29,400	2,500	3,400	5.97
3217	3.3465 85	5.9055 150	1.9375 49.21	0.079 2	27,300	35,000	2,400	3,200	7.67
3218	3.5433 90	6.2992 160	2.0625 52.39	0.079 2	30,500	38,000	2,200	3,000	9.35
3219	3.7402 95	6.6929 170	2.1875 55.56	0.083 2.1	32,500	41,500	2,100	2,800	11.2
3220	3.9370 100	7.0866 180	2.3750 60.33	0.083 2.1	42,500	52,500	2,000	2,700	13.0
3302	0.5906 15	1.6535 42	0.7500 19.05	0.039 1	3,200	2,660	9,900	13,000	0.280
3303	0.6693 17	1.8504 47	0.8750 22.23	0.039 1	3,950	3,350	9,000	12,000	0.408
3304	0.7874 20	2.0472 52	0.8750 22.23	0.043 1.1	4,750	4,150	8,000	11,000	0.487
3305	0.9843 25	2.4409 62	1.0000 25.40	0.043 1.1	6,600	6,000	6,700	8,900	0.780
3306	1.1811 30	2.8346 72	1.1875 30.16	0.043 1.1	8,700	8,200	5,700	7,600	1.23
3307	1.3780 35	3.1496 80	1.3750 34.93	0.059 1.5	11,100	10,700	5,000	6,600	1.67
3308	1.5748 40	3.5433 90	1.4375 36.51	0.059 1.5	12,200	12,900	4,400	5,900	2.27
3309	1.7717 45	3.9370 100	1.5625 39.69	0.059 1.5	15,100	16,300	4,000	5,300	3.02
3310	1.9685 50	4.3307 110	1.7500 44.45	0.079 2	18,300	20,100	3,600	4,800	4.37
3311	2.1654 55	4.7244 120	1.9375 49.21	0.079 2	21,700	24,300	3,300	4,400	5.34
3312	2.3622 60	5.1181 130	2.1250 53.98	0.083 2.1	25,400	28,900	3,000	4,000	6.77
3313	2.5591 65	5.5118 140	2.3125 58.74	0.083 2.1	29,400	34,000	2,800	3,700	8.60
3314	2.7559 70	5.9055 150	2.5000 63.50	0.083 2.1	34,500	38,000	2,600	3,500	11.5
3315	2.9528 75	6.2992 160	2.6875 68.26	0.083 2.1	38,500	43,000	2,400	3,200	13.9

DOUBLE ROW ANGULAR CONTACT BALL BEARINGS

Units: INCHES
Millimeters

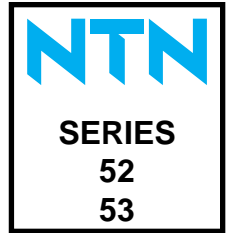

Bearing No.	Bore <i>d</i>	O.D. <i>D</i>	Width <i>B</i>	Fillet Radius <i>r</i>	Basic Load Ratings (lbs)		Limiting Speeds (rpm)		Weight (lbs)
					Dynamic <i>C</i>	Static <i>Co</i>	Grease	Oil	
5200	0.3937 10	1.1811 30	0.5630 14.3	0.024 0.6	1,560	855	14,000	19,000	0.108
5201	0.4724 12	1.2598 32	0.6260 15.9	0.024 0.6	2,050	1,140	13,000	17,000	0.126
5202	0.5906 15	1.3780 35	0.6260 15.9	0.024 0.6	2,260	1,360	11,000	15,000	0.141
5203	0.6693 17	1.5748 40	0.6890 17.5	0.024 0.6	2,870	1,770	9,900	13,000	0.212
5204	0.7874 20	1.8504 47	0.8110 20.6	0.039 1	4,300	2,710	8,800	12,000	0.337
5205	0.9843 25	2.0472 52	0.8110 20.6	0.039 1	4,650	3,200	7,300	9,800	0.386
5206	1.1811 30	2.4409 62	0.9370 23.8	0.039 1	6,450	4,600	6,300	8,400	0.631
5207	1.3780 35	2.8346 72	1.0630 27.0	0.043 1.1	8,500	6,250	5,500	7,400	0.961
5208	1.5748 40	3.1496 80	1.1890 30.2	0.043 1.1	9,600	7,250	4,900	6,600	1.30
5209	1.7717 45	3.3465 85	1.1890 30.2	0.043 1.1	10,800	8,300	4,400	5,900	1.41
5210	1.9685 50	3.5433 90	1.1890 30.2	0.043 1.1	11,500	9,400	4,000	5,300	1.52
5211	2.1654 55	3.9370 100	1.3110 33.3	0.059 1.5	14,200	11,900	3,600	4,900	2.17
5212	2.3622 60	4.3307 110	1.4370 36.5	0.059 1.5	16,100	13,100	3,400	4,500	2.80
5213	2.5591 65	4.7244 120	1.5000 38.1	0.059 1.5	18,700	16,300	3,100	4,200	3.46
5214	2.7559 70	4.9213 125	1.5630 39.7	0.059 1.5	20,400	17,900	2,900	3,900	3.97
5215	2.9528 75	5.1181 130	1.6260 41.3	0.059 1.5	20,300	18,100	2,700	3,600	4.19
5216	3.1496 80	5.5118 140	1.7480 44.4	0.079 2	23,800	21,400	2,500	3,400	5.27
5217	3.3465 85	5.9055 150	1.9370 49.2	0.079 2	25,100	23,900	2,400	3,200	6.75
5218	3.5433 90	6.2992 160	2.0630 52.4	0.079 2	31,500	29,000	2,200	3,000	8.22
5219	3.7402 95	6.6929 170	2.1890 55.6	0.083 2.1	35,500	33,000	2,100	2,800	10.7
5220	3.9370 100	7.0866 180	2.3740 60.3	0.083 2.1	40,000	37,500	2,000	2,700	13.1
5302	0.5906 15	1.6535 42	0.7480 19	0.039 1	3,850	2,260	9,900	13,000	0.291
5303	0.6693 17	1.8504 47	0.8740 22.2	0.039 1	2,870	1,770	9,000	12,000	0.212
5304	0.7874 20	2.0472 52	0.8740 22.2	0.043 1.1	4,650	2,850	8,000	11,000	0.478
5305	0.9843 25	2.4409 62	1.0000 25.4	0.043 1.1	6,850	4,600	6,700	8,900	0.798
5206	1.1811 30	2.8346 72	1.1890 30.2	0.043 1.1	8,900	6,200	5,700	7,600	1.22
5307	1.3780 35	3.1496 80	1.3740 34.9	0.059 1.5	11,100	7,850	5,000	6,600	1.69
5308	1.5748 40	3.5433 90	1.4370 36.5	0.059 1.5	13,600	9,850	4,400	5,900	2.23
5309	1.7717 45	3.9370 100	1.5630 39.7	0.059 1.5	16,300	12,100	4,000	5,300	2.95
5310	1.9685 50	4.3307 110	1.7480 44.4	0.079 2	19,200	14,500	3,600	4,800	3.99
5311	2.1654 55	4.7244 120	1.9370 49.2	0.079 2	23,900	18,500	3,300	4,400	5.11
5312	2.3622 60	5.1181 130	2.1260 54.0	0.083 2.1	27,300	21,400	3,000	4,000	6.72
5313	2.5591 65	5.5118 140	2.3110 58.7	0.083 2.1	31,000	24,600	2,800	3,700	8.73
5314	2.7559 70	5.9055 150	2.5000 63.5	0.083 2.1	35,000	28,000	2,600	3,500	10.4
5315	2.9528 75	6.2992 160	2.6890 68.3	0.083 2.1	38,000	31,500	2,400	3,200	12.5

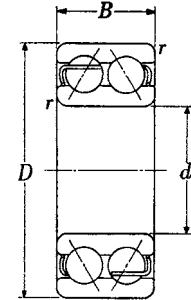

52

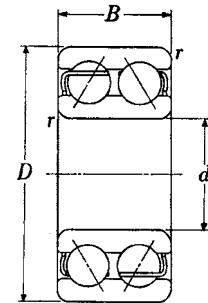

53

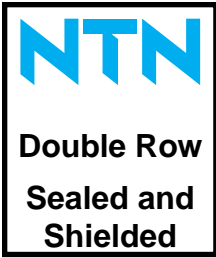

Units: **INCHES**
Millimeters

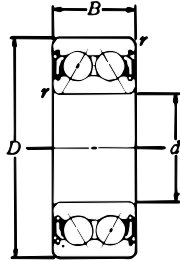

Type ZZ
with two shields

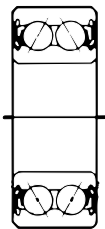

Type LLB
with two seals
(non-contact)

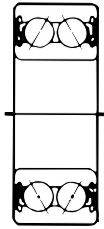

Type LLU
with two seals
(contact)

DOUBLE ROW ANGULAR CONTACT BALL BEARINGS

Bearing No.	Bore <i>d</i>	O.D. <i>D</i>	Width <i>B</i>	Fillet Radius <i>r</i>	Basic Load Ratings (lbs)		Limiting Speeds (rpm)		Weight (lbs)	
					Dynamic <i>C</i>	Static <i>Co</i>	Grease			
							ZZ, LLM	LLD		Oil Z, LM
5200CZZ, LLB, LLU	0.3937 10	1.1811 30	0.5630 14.3	0.024 0.6	1,560	855	17,000	15,000	22,000	.108
5201CZZ, LLB, LLU	0.4724 12	1.2598 32	0.6260 15.9	0.024 0.6	1,710	1,010	15,000	12,000	20,000	.126
5202CZZ, LLB, LLU	0.5906 15	1.3780 35	0.6260 15.9	0.024 0.6	1,840	1,180	13,000	12,000	17,000	.141
5203CZZ, LLB, LLU	0.6693 17	1.5748 40	0.6890 17.5	0.024 0.6	2,430	1,590	11,000	10,000	15,000	.212
5204CZZ, LLB, LLU	0.7874 20	1.8504 47	0.8110 20.6	0.039 1	3,550	2,280	10,000	9,000	13,000	.337
5205CZZ, LLB, LLU	0.9843 25	2.0472 52	0.8110 20.6	0.039 1	4,100	2,970	8,500	7,500	11,000	.386
5206CZZ, LLB, LLU	1.1811 30	2.4409 62	0.9370 23.8	0.039 1	5,850	4,400	7,100	6,300	9,500	.631
5207CZZ, LLB, LLU	1.3780 35	2.8346 72	1.0630 27.0	0.043 1.1	7,400	5,500	6,300	5,300	8,500	.961
5208CZZ, LLB, LLU	1.5748 40	3.1496 80	1.1890 30.2	0.043 1.1	9,050	7,150	5,600	4,800	7,100	1.30
5303CZZ, LLB, LLU	0.6693 17	1.8504 47	0.8740 22.2	0.039 1	4,250	2,670	10,000	9,500	13,000	.399
5305CZZ, LLB, LLU	0.9843 25	2.4409 62	1.0000 25.4	0.043 1.1	5,950	4,050	7,500	6,300	10,000	.798
5306CZZ, LLB, LLU	1.1811 30	2.8346 72	1.1890 30.2	0.043 1.1	7,400	5,450	6,300	5,300	8,500	1.22
5307CZZ, LLB, LLU	1.3780 35	3.1496 80	1.3740 34.9	0.059 1.5	11,100	7,850	5,600	4,800	7,500	1.69
5308CZZ, LLB, LLU	1.5748 40	3.5433 90	1.4370 36.5	0.059 1.5	12,400	9,000	5,300	4,500	6,700	2.23

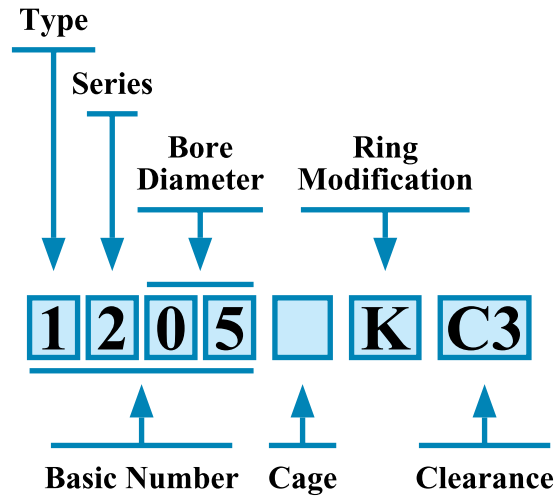

1. TYPE

- 1: Standard for self-aligning ball bearings
- 2: Standard for self-aligning ball bearings

2. CAGE

- No Symbol: Standard cage
- J: Pressed steel cage
- T2: Plastic cage, nylon or teflon
- L1: Machined brass cage

3. RING MODIFICATION

- K: 1:12 tapered bore

4. INTERNAL CLEARANCE

- C1: Radial clearance less than C2
- C2: Radial clearance less than normal
- C3: Radial clearance greater than normal
- C4: Radial clearance greater than C3
- C5: Radial clearance greater than C4
- CSXX: Special radial clearance;
XX is mean value in 0.001 mm units



Units: **INCHES**
Millimeters

SELF-ALIGNING BALL BEARINGS

Bearing No.		Bore	O.D.	Width	Fillet Radius	Basic Load Ratings (lbs)		Weight (lbs)		Limiting Speeds (rpm)	
<i>12</i>	<i>12K</i>	<i>d</i>	<i>D</i>	<i>B</i>	<i>r</i>	<i>Dynamic C</i>	<i>Static C0</i>	<i>12</i>	<i>12K</i>	Grease	Oil
1200	—	0.3937 10	1.1811 30	0.3543 9	0.024 0.6	1,230	268	.075	—	21,000	24,000
1201	—	0.4724 12	1.2598 32	0.3937 10	0.024 0.6	1,260	286	.088	—	18,000	22,000
1202	—	0.5906 15	1.3780 35	0.4331 11	0.024 0.6	1,680	395	.108	—	16,000	19,000
1203	—	0.6693 17	1.5748 40	0.4724 12	0.024 0.6	1,770	450	.161	—	14,000	17,000
1204	1204K	0.7874 20	1.8504 47	0.5512 14	0.039 1.0	2,230	585	.265	.26	13,000	15,000
1205	1205K	0.9843 25	2.0472 52	0.5906 15	0.039 1.0	2,720	740	.311	.304	11,000	13,000
1206	1206K	1.1811 30	2.4409 62	0.6299 16	0.039 1.0	3,500	1,050	.485	.476	9,200	11,000
1207	1207K	1.3780 35	2.8346 72	0.6693 17	0.043 1.1	3,550	1,150	.712	.699	8,000	9,400
1208	1208K	1.5748 40	3.1496 80	0.7087 18	0.043 1.1	4,350	1,470	.919	.906	7,100	8,400
1209	1209K	1.7717 45	3.3465 85	0.7480 19	0.043 1.1	4,900	1,650	1.03	1.01	6,400	7,500
1210	1210K	1.9685 50	3.5433 90	0.7874 20	0.043 1.1	5,100	1,820	1.16	1.14	5,800	6,800
1211	1211K	2.1654 55	3.9370 100	0.8268 21	0.059 1.5	6,000	2,250	1.55	1.53	5,300	6,200
1212	1212K	2.3622 60	4.3307 110	0.8661 22	0.059 1.5	6,800	2,590	1.98	1.95	4,900	5,800
1213	1213K	2.5591 65	4.7244 120	0.9055 23	0.059 1.5	6,950	2,820	2.54	2.49	4,500	5,300
1214	—	2.7559 70	4.9213 125	0.9449 24	0.059 1.5	7,800	3,100	2.78	—	4,200	4,900
1215	1215K	2.9528 75	5.1181 130	0.9843 25	0.059 1.5	8,750	3,550	3	2.95	3,900	4,600
1216	1216K	3.1496 80	5.5118 140	1.0236 26	0.079 2	8,950	3,800	3.68	3.62	3,700	4,300
1217	1217K	3.3465 85	5.9055 150	1.1024 28	0.079 2	11,000	4,650	4.56	4.5	3,500	4,100
1218	1218K	3.5433 90	6.2992 160	1.1811 30	0.079 2	12,800	5,300	5.56	5.47	3,300	3,800
1219	1219K	3.7402 95	6.6929 170	1.2598 32	0.083 2.1	14,300	6,100	6.83	6.72	3,100	3,600
1220	1220K	3.9370 100	7.0866 180	1.3386 34	0.083 2.1	15,500	6,700	8.16	8.02	2,900	3,400
1221	—	4.1339 105	7.4803 190	1.4173 36	0.083 2.1	16,700	7,300	9.63	—	2,800	3,300
1222	1222K	4.3307 110	7.8740 200	1.4961 38	0.083 2.1	18,100	7,950	11.4	11.2	2600	3100

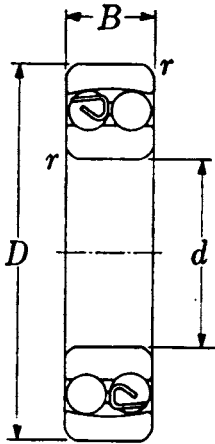

Cylindrical Bore
12

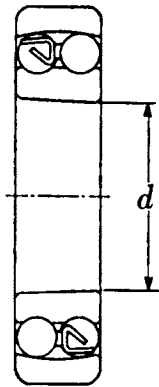

Tapered Bore
12K
Taper 1:12

The d dimension for the tapered bore is measured from the side of the bearing with the smallest bore dimension.

SELF-ALIGNING BALL BEARINGS

Units: INCHES
Millimeters



Bearing No.		Bore	O.D.	Width	Fillet Radius	Basic Load Ratings (lbs)		Weight (lbs)		Limiting Speeds (rpm)	
22	22K	<i>d</i>	<i>D</i>	<i>B</i>	<i>r</i>	Dynamic <i>C</i>	Static <i>C0</i>	22	22K	Grease	Oil
2200	—	0.3937 10 30	1.1811 30 14	0.5512 14 0.6	0.024 0.6	1,640	360	0.104	—	19,000	23,000
2201	—	0.4724 12 32	1.2598 32 14	0.5512 14 0.6	0.024 0.6	1,710	390	0.117	—	17,000	20,000
2202	—	0.5906 15 35	1.3780 35 14	0.5512 14 0.6	0.024 0.6	1,730	415	0.132	—	15,000	18,000
2203	—	0.6693 17 40	1.5748 40 16	0.6299 16 0.6	0.024 0.6	2,200	545	0.194	—	13,000	16,000
2204	2204K	0.7874 20 47	1.8504 47 18	0.7087 18 1	0.039 1	2,830	745	0.309	0.300	12,000	14,000
2205	2205K	0.9843 25 52	2.0472 52 18	0.7087 18 1	0.039 1	2,760	775	0.359	0.348	10,000	12,000
2206	2206K	1.1811 30 62	2.4409 62 20	0.7874 20 1	0.039 1	3,400	1,020	0.573	0.560	8,600	10,000
2207	2207K	1.3780 35 72	2.8346 72 23	0.9055 23 1.1	0.043 1.1	4,850	1,480	0.888	0.873	7,500	8,800
2208	2208K	1.5748 40 80	3.1496 80 23	0.9055 23 1.1	0.043 1.1	5,000	1,650	1.11	1.09	6,700	7,900
2209	2209K	1.7717 45 85	3.3465 85 23	0.9055 23 1.1	0.043 1.1	5,200	1,830	1.20	1.18	6,000	7,100
2210	2210K	1.9685 50 90	3.5433 90 23	0.9055 23 1.1	0.043 1.1	5,200	1,900	1.30	1.27	5,500	6,400
2211	2211K	2.1654 55 100	3.9370 100 25	0.9843 25 1.5	0.059 1.5	5,950	2,220	1.79	1.75	5,000	5,800
2212	2212K	2.3622 60 110	4.3307 110 28	1.1024 28 1.5	0.059 1.5	7,650	2,840	2.40	2.36	4,600	5,400
2213	2213K	2.5591 65 120	4.7244 120 31	1.2205 31 1.5	0.059 1.5	9,750	3,700	3.22	3.15	4,200	5,300
2214	—	2.7559 70 125	4.9213 125 31	1.2205 31 1.5	0.059 1.5	9,850	3,850	3.35	—	3,900	4,600
2215	2215K	2.9528 75 130	5.1181 130 31	1.2205 31 1.5	0.059 1.5	9,950	4,000	3.57	3.48	3,700	4,300
2216	2216K	3.1496 80 140	5.5118 140 33	1.2992 33 2.0	.079 2.0	10,900	4,450	4.43	4.34	3,400	4,000
2217	2217K	3.3465 85 150	5.9055 150 36	1.4173 36 2.0	.079 2.0	13,100	5,300	5.56	5.42	3,200	3,800
2218	2218K	3.5433 90 160	6.2992 160 40	1.5748 40 2.0	.079 2.0	15,800	6,450	7.50	7.34	3,100	3,600
2219	2219K	3.7402 95 170	6.6929 170 43	1.6929 43 2.1	.083 2.1	18,700	7,750	9.04	8.82	2,900	3,400
2220	2220K	3.9370 100 180	7.0866 180 46	1.8110 46 2.1	.083 2.1	21,100	8,650	11.0	10.7	2,700	3,200
2221	—	4.1339 105 190	7.4803 190 50	1.9685 50 2.1	.083 2.1	24,400	10,100	13.4	—	2,600	3,100
2222	2222K	4.3307 110 200	7.8740 200 53	2.0866 53 2.1	.083 2.1	27,900	11,600	15.7	15.3	2,500	2,900

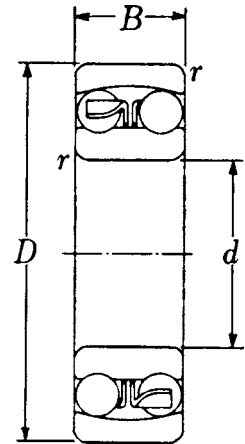

Cylindrical Bore
22

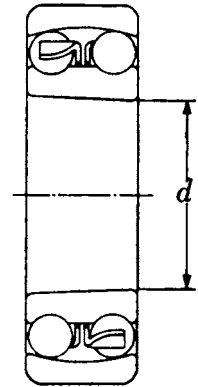

Tapered Bore
22K
Taper 1:12

The d dimension for the tapered bore is measured from the side of the bearing with the smallest bore dimension.



Units: **INCHES**
Millimeters

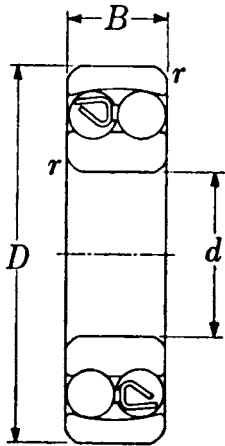

Cylindrical Bore
13

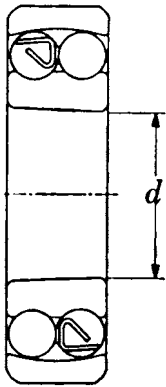

Tapered Bore
13K
Taper 1:12

SELF-ALIGNING BALL BEARINGS

Bearing No.		Bore	O.D.	Width		Fillet Radius	Basic Load Ratings (lbs)		Weight (lbs)		Limiting Speeds (rpm)	
<i>13</i>	<i>13K</i>	<i>d</i>	<i>D</i>	<i>B</i>	<i>B1*</i>	<i>r</i>	<i>Dynamic C</i>	<i>Static Co</i>	<i>13</i>	<i>13K</i>	Grease	Oil
1300	—	0.3937 10	1.3780 35	0.4331 11	—	0.024 0.6	1,630	365	0.128	—	18,000	21,000
1301	—	0.4724 12	1.4567 37	0.4724 12	—	0.039 1	2,130	485	0.148	—	16,000	18,000
1302	—	0.5906 15	1.6535 42	0.5118 13	—	0.039 1	2,150	515	0.207	—	13,000	16,000
1303	—	0.6693 17	1.8504 47	0.5512 14	—	0.039 1	2,820	715	0.287	—	12,000	14,000
1304	1304K	0.7874 20	2.0472 52	0.5906 15	—	0.043 1.1	2,790	750	0.359	0.355	11,000	13,000
1305	1305K	0.9843 25	2.4409 62	0.6693 17	—	0.043 1.1	4,050	1,130	0.567	0.556	9,100	11,000
1306	1306K	1.1811 30	2.8346 72	0.7480 19	—	0.043 1.1	4,800	1,420	0.853	0.840	7,700	9,100
1307	1307K	1.3780 35	3.1496 80	0.8268 21	—	0.059 1.5	5,650	1,770	1.12	1.11	6,800	8,000
1308	1308K	1.5748 40	3.5433 90	0.9055 23	—	0.059 1.5	6,650	2,180	1.58	1.55	6,000	7,000
1309	1309K	1.7717 45	3.9370 100	0.9843 25	—	0.059 1.5	8,550	2,860	2.11	2.08	5,400	6,300
1310	1310K	1.9685 50	4.3307 110	1.0630 27	—	0.079 2.0	9,750	3,150	2.67	2.62	4,900	5,800
1311	1311K	2.1654 55	4.7244 120	1.1417 29	—	0.079 2.0	11,600	4,000	3.48	3.44	4,500	5,200
1312	1312K	2.3622 60	5.1181 130	1.2205 31	—	0.083 2.1	12,900	4,700	4.32	4.25	4,100	4,800
1313	1313K	2.5591 65	5.5118 140	1.2992 33	—	0.083 2.1	13,900	5,150	5.40	5.31	3,800	4,500
1314	—	2.7559 70	5.9055 150	1.3780 35	—	0.083 2.1	16,700	6,250	6.59	—	3,500	4,200
1315	1315K	2.9528 75	6.2992 160	1.4567 37	—	0.083 2.1	17,800	6,750	7.85	7.74	3,300	3,900
1316	1316K	3.1496 80	6.6929 170	1.5354 39	—	0.083 2.1	19,900	7,450	9.22	9.08	3,100	3,600
1317	1317K	3.3465 85	7.0866 180	1.6142 41	—	0.118 3	22,000	8,500	11.0	10.8	2,900	3,400
1318	1318K	3.5433 90	7.4803 190	1.6929 43	1.772 45	0.118 3	26,100	10,000	12.8	12.6	2,700	3,200
1319	1319K	3.7402 95	7.8740 200	1.7717 45	1.890 48	0.118 3	29,600	11,400	14.7	14.5	2,600	3,000
1320	1320K	3.9370 100	8.4646 215	1.8504 47	2.047 52	0.118 3	32,000	12,900	18.3	18.1	2,400	2,900
1321	—	4.1339 105	8.8583 225	1.9291 49	2.126 54	0.118 3	35,000	14,500	22.0	—	2,300	2,700
1322	1322K	4.3307 110	9.4488 240	1.9685 50	2.165 55	0.118 3	37,000	16,100	26.0	25.8	2,200	2,600

* B_1 is the combined width of the balls. Note that for bearings No. 1318(K) - 1322(K), the balls project beyond the ring face ($B_1 > B$).

The d dimension for the tapered bore is measured from the side of the bearing with the smallest bore dimension.

SELF-ALIGNING BALL BEARINGS

Units: INCHES
Millimeters



Bearing No.		Bore	O.D.	Width	Fillet Radius	Basic Load Ratings (lbs)		Weight (lbs)		Limiting Speeds (rpm)	
23	23K	<i>d</i>	<i>D</i>	<i>B</i>	<i>r</i>	Dynamic <i>C</i>	Static <i>C0</i>	22	22K	Grease	Oil
2300	—	0.3937 10	1.3780 35	0.6693 17	0.024 0.6	2,270	485	0.183	—	17,000	20,000
2301	—	0.4724 12	1.4567 37	0.6693 17	0.039 1	2,640	610	0.201	—	15,000	17,000
2302	—	0.5906 15	1.6535 42	0.6693 17	0.039 1	2,700	650	0.251	—	13,000	15,000
2303	—	0.6693 17	1.8504 47	0.7480 19	0.039 1	3,250	800	0.348	—	11,000	14,000
2304	2304K	0.7874 20	2.0472 52	0.8268 21	0.043 1.1	4,050	1,060	0.461	0.452	10,000	12,000
2305	2305K	0.9843 25	2.4409 62	0.9449 24	0.043 1.1	5,500	1,480	0.739	0.721	8,500	10,000
2306	2306K	1.1811 30	2.8346 72	1.0630 27	0.043 1.1	7,050	1,970	1.10	1.08	7,200	8,500
2307	2307K	1.3780 35	3.1496 80	1.2205 31	0.059 1.5	8,850	2,530	1.49	1.45	6,300	7,400
2308	2308K	1.5748 40	3.5433 90	1.2992 33	0.059 1.5	10,100	3,050	2.04	1.99	5,600	6,600
2309	2309K	1.7717 45	3.9370 100	1.4173 36	0.059 1.5	12,200	3,750	2.71	2.65	5,000	5,900
2310	2310K	1.9685 50	4.3307 110	1.5748 40	0.079 2.0	14,500	4,550	3.62	3.53	4,600	5,400
2311	2311K	2.1654 55	4.7244 120	1.6929 43	0.079 2.0	16,900	5,400	4.63	4.52	4,200	4,900
2312	2312K	2.3622 60	5.1181 130	1.8110 46	0.083 2.1	19,600	6,350	5.73	5.58	3,800	4,500
2313	2313K	2.5591 65	5.5118 140	1.8898 48	0.083 2.1	21,600	7,300	7.12	6.94	3,600	4,200
2314	—	2.7559 70	5.9055 150	2.0079 51	0.083 2.1	24,600	8,450	8.60	—	3,300	3,900
2315	2315K	2.9528 75	6.2992 160	2.1654 55	0.083 2.1	27,700	9,650	10.4	10.2	3,100	3,600
2316	2316K	3.1496 80	6.6929 170	2.2835 58	0.083 2.1	28,800	10,200	13.4	13.1	2,900	3,400
2317	2317K	3.3465 85	7.0866 180	2.3622 60	0.118 3	31,500	11,500	15.5	15.2	2,700	3,200
2318	2318K	3.5433 90	7.4803 190	2.5197 64	0.118 3	34,000	12,900	18.6	18.2	2,600	3,000
2319	2319K	3.7402 95	7.8740 200	2.6378 67	0.118 3	37,000	14,500	21.6	21.1	2,400	2,800
2320	2320K	3.9370 100	8.4646 215	2.8740 73	0.118 3	43,000	17,800	27.3	26.7	2,300	2,700
2321	—	4.1339 105	8.8583 225	3.0315 77	0.118 3	46,000	19,500	31.5	—	2,200	2,600
2322	2322K	4.3307 110	9.4488 240	3.1496 80	0.118 3	48,500	21,300	38.1	37.3	2,100	2,400

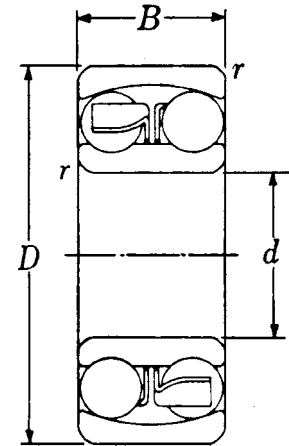

Cylindrical Bore
23

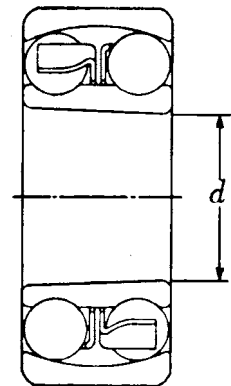

Tapered Bore
23K
Taper 1:12

The *d* dimension for the tapered bore is measured from the side of the bearing with the smallest bore dimension.

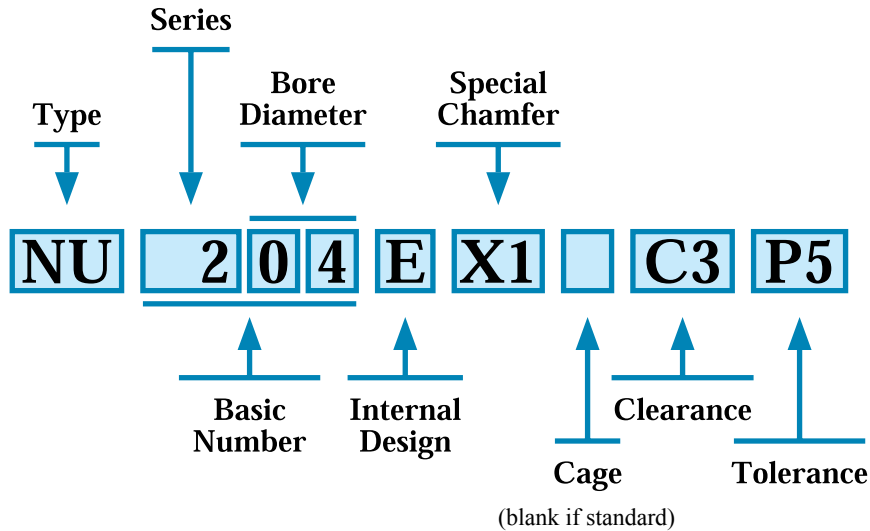
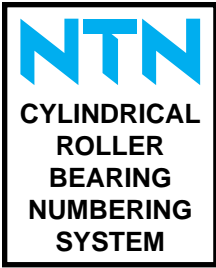

1. TYPE

- N: Straight outer ring with inner ring and roller assembly
- NU: Straight inner ring with outer ring and roller assembly
- NF: One lip outer ring with inner ring and roller assembly
- NJ: One lip inner ring with outer ring and roller assembly
- NH: NJ series bearing with HJ thrust collar (NJ+HJ=NH)
- NN: Double row precision cylindrical bearings
- HJ: Separate thrust collar
- R, RN, RNU: Special cylindrical roller bearings

2. SERIES

- 10: Standard series cylindrical roller bearings
- 2: Standard series cylindrical roller bearings
- 22: Standard series cylindrical roller bearings
- 23: Standard series cylindrical roller bearings
- 3: Standard series cylindrical roller bearings
- 4: Standard series cylindrical roller bearings

3. INTERNAL DESIGN

- E: High capacity cylindrical roller bearings

4. CHAMFER

- Xn: Special chamfer, from 1 onward (X1, X2 . . .)

5. CAGE

- F1: Machined steel cage
- J: Pressed steel cage
- G1: Machined brass cage
- T2: Nylon cage

6. INTERNAL CLEARANCE

- C1: Radial clearance less than C2
- C2: Radial clearance less than normal
- No Suffix: Normal Radial Clearance
- C3: Radial clearance greater than normal
- C4: Radial clearance greater than C3
- C5: Radial clearance greater than C4
- CSXX: Special radial clearance; XX is mean value in 0.001 mm units (µm)
- NA: Radial clearance of cylindrical roller bearings with non-interchangeable components

7. TOLERANCE

- Normal: ISO class 0
- P6: ISO class 6 (equivalent to RBEC 3)
- P5: ISO class 5 (equivalent to RBEC 5)
- P4: ISO class 4 (equivalent to RBEC 7)

CYLINDRICAL ROLLER BEARINGS

Units: INCHES
Millimeters



Bearing No.	Bore d	O.D. D	Width B	Fillet Radii		Outer Ring I.D. D _r	Inner Ring O.D. d _r	Basic Load Ratings (lbs)		Weight (lbs)	
				r	r ₁			Dynamic C	Static C ₀	N10	NU10
1005	.9843 25	1.8504 47	.4724 12	.024 .6	.012 .3	1.6339 41.5	1.2008 30.5	3,400	3,150	.201	.203
1006	1.1811 30	2.1654 55	.5118 13	.039 1.0	.024 .6	1.9094 48.5	1.4370 36.5	4,400	4,400	.291	.295
1007	1.3780 35	2.4409 62	.5512 14	.039 1.0	.024 .6	2.1654 55.0	1.6535 42.0	5,100	5,200	.386	.392
1008	1.5748 40	2.6772 68	.5906 15	.039 1.0	.024 .6	2.4016 61.0	1.8504 47.0	6,150	6,500	.481	.487
1009	1.7717 45	2.9528 75	.6299 16	.039 1.0	.024 .6	2.6575 67.5	2.0669 52.5	7,000	7,600	.608	.617
1010	1.9685 50	3.1496 80	.6299 16	.039 1.0	.024 .6	2.8543 72.5	2.2638 57.5	7,200	8,100	.653	.661
1011	2.1654 55	3.5433 90	.7087 18	.059 1.5	.039 1.0	3.1693 80.5	2.5394 64.5	8,450	9,850	.959	.974
1012	2.3622 60	3.7402 95	.7087 18	.059 1.5	.039 1.0	3.3661 85.5	2.7362 69.5	9,000	10,900	1.03	1.04
1013	2.5591 65	3.9370 100	.7087 18	.059 1.5	.039 1.0	3.5630 90.5	2.9331 74.5	9,250	11,500	1.10	1.11
1014	2.7559 70	4.3307 110	.7874 20	.059 1.5	.039 1.0	3.9370 100.0	3.1496 80.0	13,100	15,800	1.52	1.54
1015	2.9528 75	4.5276 115	.7874 20	.059 1.5	.039 1.0	4.1339 105.0	3.3465 85.0	13,500	16,700	1.60	1.63
1016	3.1496 80	4.9213 125	.8661 22	.059 1.5	.039 1.0	4.4685 113.5	3.6024 91.5	16,300	20,400	2.13	2.16
1017	3.3465 85	5.1181 130	.8661 22	.059 1.5	.039 1.0	4.6654 118.5	3.7992 96.5	16,700	21,500	2.23	2.27
1018	3.5433 90	5.5118 140	.9449 24	.079 2.0	.059 1.5	5.0000 127.0	4.0551 103.0	19,800	25,700	2.91	2.95
1019	3.7402 95	5.7087 145	.9449 24	.079 2.0	.059 1.5	5.1969 132.0	4.2520 108.0	20,400	27,000	3.04	3.09
1020	3.9370 100	5.9055 150	.9449 24	.079 2.0	.059 1.5	5.3937 137.0	4.4488 113.0	20,900	28,300	3.15	3.20
1021	4.1339 105	6.2992 160	1.0236 26	.098 2.5	.059 1.5	5.7283 145.5	4.7047 119.5	23,700	32,000	3.99	4.06
1022	4.3307 110	6.6929 170	1.1024 28	.098 2.5	.059 1.5	6.1024 155.0	4.9213 125.0	29,500	39,000	4.96	5.03
1024	4.7244 120	7.0866 180	1.1024 28	.098 2.5	.059 1.5	6.4961 165.0	5.3150 135.0	31,000	43,000	5.29	5.38
1026	5.1181 130	7.8740 200	1.2992 33	.098 2.5	.059 1.5	7.1654 182.0	5.8268 148.0	38,500	53,500	8.00	8.14
1028	5.5118 140	8.2677 210	1.2992 33	.098 2.5	.059 1.5	7.5591 192.0	6.2205 158.0	39,500	56,000	8.51	8.64
1030	5.9055 150	8.8583 225	1.3780 35	.098 2.5	.079 2.0	8.0906 205.5	6.6732 169.5	45,500	66,000	10.4	10.5
1032	6.2992 160	9.4488 240	1.4961 38	.098 2.5	.079 2.0	8.6614 220.0	7.0866 180.0	53,500	77,000	12.8	13.0
1034	6.6929 170	10.2362 260	1.6535 42	.098 2.5	.098 2.5	9.3307 237.0	7.5984 193.0	62,500	90,000	17.1	17.4
1036	7.0866 180	11.0236 280	1.8110 46	.098 2.5	.098 2.5	10.0394 255.0	8.0709 205.0	77,000	110,000	22.3	22.7
1038	7.4803 190	11.4173 290	1.8110 46	.098 2.5	.098 2.5	10.4331 265.0	8.4646 215.0	79,000	115,000	23.1	23.6
1040	7.8740 200	12.2047 310	2.0079 51	.098 2.5	.098 2.5	11.0630 281.0	9.0157 229.0	87,500	131,000	30.2	30.6
1044	8.6614 220	13.3858 340	2.2047 56	.118 3.0	.118 3.0	12.2047 310.0	9.8425 250.0	113,000	168,000	39.5	40.1
1048	9.4488 240	14.1732 360	2.2047 56	.118 3.0	.118 3.0	12.9921 330.0	10.6299 270.0	119,000	184,000	42.5	43.2
1052	10.2362 260	15.7480 400	2.5591 65	.157 4.0	.157 4.0	14.3307 364.0	11.6535 296.0	145,000	224,000	63.3	64.2
1056	11.0236 280	16.5354 420	2.5591 65	.157 4.0	.157 4.0	15.1181 384.0	12.4409 316.0	148,000	235,000	67.0	68.1
1060	11.8110 300	18.1102 460	2.9134 74	.157 4.0	.157 4.0	16.5354 420.0	13.3858 340.0	192,000	300,000	94.6	96.1
1064	12.5984 320	18.8976 480	2.9134 74	.157 4.0	.157 4.0	17.3228 440.0	14.1732 360.0	197,000	315,000	99.9	101

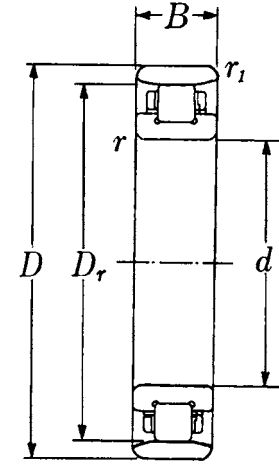

N10

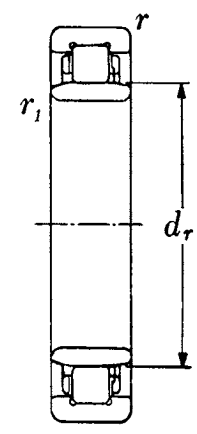

NU10

These figures may vary slightly according to cage type and type of bearing.



Units: INCHES
Millimeters

CYLINDRICAL ROLLER BEARINGS

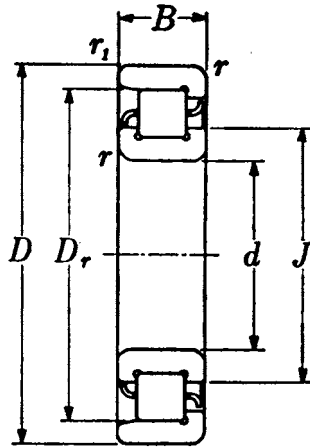

NF2

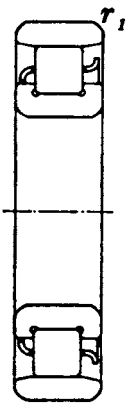

N2

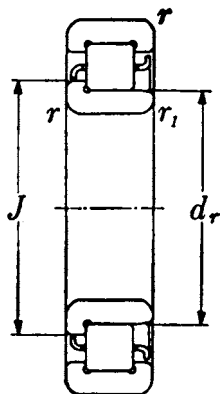

NJ2

Bearing No.	Bore	O.D.	Width	Fillet Radii		Outer Ring I.D.	Inner Ring O.D.	Shoulder Height
	<i>d</i>	<i>D</i>		<i>r</i>	<i>r₁</i>			
204	.7874 20	1.8504 47	.5512 14	.039 1.0	.024 .6	1.5748 40.0	1.0630 27.0	1.181 30.0
205	.9843 25	2.0472 52	.5906 15	.039 1.0	.024 .6	1.7717 45.0	1.2598 32.0	1.378 35.0
206	1.1811 30	2.4409 62	.6299 16	.039 1.0	.024 .6	2.1063 53.5	1.5157 38.5	1.646 41.8
207	1.3780 35	2.8346 72	.6693 17	.059 1.5	.024 .6	2.4331 61.8	1.7244 43.8	1.874 47.6
208	1.5748 40	3.1496 80	.7087 18	.059 1.5	.059 1.5	2.7559 70.0	1.9685 50.0	2.134 54.2
209	1.7717 45	3.3465 85	.7480 19	.059 1.5	.059 1.5	2.9528 75.0	2.1654 55.0	2.323 59.0
210	1.9685 50	3.5433 90	.7874 20	.059 1.5	.059 1.5	3.1654 80.4	2.3780 60.4	2.543 64.6
211	2.1654 55	3.9370 100	.8268 21	.079 2.0	.059 1.5	3.4843 88.5	2.6181 66.5	2.787 70.8
212	2.3622 60	4.3307 110	.8661 22	.079 2.0	.079 2.0	3.8386 97.5	2.8937 73.5	3.087 78.4
213	2.5591 65	4.7244 120	.9055 23	.079 2.0	.079 2.0	4.1575 105.6	3.1339 79.6	3.339 84.8
214	2.7559 70	4.9213 125	.9449 24	.079 2.0	.079 2.0	4.3504 110.5	3.3268 84.5	3.528 89.6
215	2.9528 75	5.1181 130	.9843 25	.079 2.0	.079 2.0	4.5866 116.5	3.4843 88.5	3.701 94.0
216	3.1496 80	5.5118 140	1.0236 26	.098 2.5	.098 2.5	4.9331 125.3	3.7520 95.3	3.984 101.2
217	3.3465 85	5.9055 150	1.1024 28	.098 2.5	.098 2.5	5.2677 133.8	4.0079 101.8	4.260 108.2
218	3.5433 90	6.2992 160	1.1811 30	.098 2.5	.098 2.5	5.6299 143.0	4.2126 107.0	4.496 114.2
219	3.7402 95	6.6929 170	1.2598 32	.098 2.5	.098 2.5	5.9646 151.5	4.4685 113.5	4.764 121.0
220	3.9370 100	7.0866 180	1.3386 34	.098 2.5	.098 2.5	6.2992 160.0	4.7244 120.0	5.039 128.0
221	4.1339 105	7.4803 190	1.4173 36	.098 2.5	.098 2.5	6.6457 168.8	4.9921 126.8	5.315 135.0
222	4.3307 110	7.8740 200	1.4961 38	.098 2.5	.098 2.5	7.0276 178.5	5.2165 132.5	5.571 141.5
224	4.7244 120	8.4646 215	1.5748 40	.098 2.5	.098 2.5	7.5394 191.5	5.6496 143.5	6.024 153.0
226	5.1181 130	9.0551 230	1.5748 40	.118 3.0	.118 3.0	8.0315 204.0	6.1417 156.0	6.516 165.5
228	5.5118 140	9.8425 250	1.6535 42	.118 3.0	.118 3.0	8.7008 221.0	6.6535 169.0	7.067 179.5
230	5.9055 150	10.6299 270	1.7717 45	.118 3.0	.118 3.0	9.3701 238.0	7.1654 182.0	7.598 193.0
232	6.2992 160	11.4173 290	1.8898 48	.118 3.0	.118 3.0	10.0394 255.0	7.6772 195.0	8.150 207.0
234	6.6929 170	12.2047 310	2.0472 52	.157 4.0	.157 4.0	10.7087 272.0	8.1890 208.0	8.681 220.5
236	7.0866 180	12.5984 320	2.0472 52	.157 4.0	.157 4.0	11.1024 282.0	8.5827 218.0	9.075 230.5
238	7.4803 190	13.3858 340	2.1654 55	.157 4.0	.157 4.0	11.7717 299.0	9.0945 231.0	9.626 244.5
240	7.8740 200	14.1732 360	2.2835 58	.157 4.0	.157 4.0	12.4409 316.0	9.6063 244.0	10.157 258.0
244	8.6614 220	15.7480 400	2.5591 65	.157 4.0	.157 4.0	13.7795 350.0	10.6299 270.0	11.260 286.0
248	9.4488 240	17.3228 440	2.8346 72	.157 4.0	.157 4.0	15.1575 385.0	11.6142 295.0	12.323 313.0
252	10.2362 260	18.8976 480	3.1496 80	.197 5.0	.197 5.0	16.5354 420.0	12.5984 320.0	13.386 340.0
256	11.0236 280	19.6850 500	3.1496 80	.197 5.0	.197 5.0	17.3228 440.0	13.3858 340.0	14.173 360.0
260	11.8110 300	21.2598 540	3.3465 85	.197 5.0	.197 5.0	18.7402 476.0	14.3307 364.0	15.236 387.0
264	12.5984 320	22.8346 580	3.6220 92	.197 5.0	.197 5.0	20.0787 510.0	15.3543 390.0	16.339 415.0

CYLINDRICAL ROLLER BEARINGS

Units: INCHES
Millimeters



Basic Load Ratings (lbs)		Weight (lbs)		Separate Thrust Collar No.	Thrust Collar Dimensions					Collar Weight (lbs)
Dynamic C	Static C_0	N2	NU2		d_t	D_t	B_t	b_t	r_t	
3,750	3,150	.240	.245	HJ204	.787	1.181	.266	.118	.024	.026
4,200	3,800	.295	.302	HJ205	.984	1.378	.285	.118	.024	.033
5,600	5,250	.448	.456	HJ206	1.181	1.646	.325	.157	.024	.055
8,000	7,700	.637	.650	HJ207	1.378	1.874	.315	.157	.024	.066
9,850	9,650	.816	.833	HJ208	1.575	2.134	.354	.197	.059	.101
10,400	10,500	.933	.952	HJ209	1.772	2.323	.374	.197	.059	.117
11,400	12,200	1.06	1.08	HJ210	1.969	2.543	.394	.197	.059	.139
13,700	14,900	1.38	1.41	HJ211	2.165	2.787	.433	.236	.059	.185
16,200	18,000	1.77	1.80	HJ212	2.362	3.087	.433	.236	.079	.238
18,900	21,200	2.20	2.25	HJ213	2.559	3.339	.433	.236	.079	.271
19,600	22,700	2.43	2.47	HJ214	2.756	3.528	.492	.276	.079	.331
22,700	26,400	2.67	2.71	HJ215	2.953	3.701	.492	.276	.079	.344
25,000	29,200	3.24	3.31	HJ216	3.150	3.984	.531	.315	.098	.456
28,300	33,500	4.03	4.12	HJ217	3.346	4.260	.551	.315	.098	.551
34,000	40,000	4.96	5.07	HJ218	3.543	4.496	.591	.354	.098	.672
37,000	44,000	6.00	6.13	HJ219	3.740	4.764	.610	.354	.118	.776
41,000	49,000	7.19	7.34	HJ220	3.937	5.039	.669	.394	.118	.979
45,000	54,000	8.53	8.71	HJ221	4.134	5.315	.689	.394	.118	1.11
54,000	65,000	10.0	10.2	HJ222	4.331	5.571	.728	.433	.118	1.36
61,000	76,000	12.0	12.3	HJ224	4.724	6.024	.748	.433	.118	1.58
63,500	81,500	16.3	16.6	HJ226	5.118	6.516	.748	.433	.118	1.85
73,000	94,500	20.4	20.9	HJ228	5.512	7.067	.748	.433	.118	2.20
84,500	111,000	25.8	26.2	HJ230	5.906	7.598	.807	.472	.118	2.73
96,000	128,000	31.3	32.0	HJ232	6.299	8.150	.827	.472	.118	3.26
107,000	143,000	38.8	39.7	HJ234	6.693	8.681	.866	.472	.157	3.75
111,000	152,000	40.3	41.2	HJ236	7.087	9.075	.866	.472	.157	3.97
125,000	173,000	48.7	49.6	HJ238	7.480	9.626	.925	.512	.157	4.85
140,000	195,000	57.8	58.9	HJ240	7.874	10.157	.984	.551	.157	5.73
171,000	242,000	80.9	82.5	HJ244	8.661	11.260	1.083	.591	.157	7.83
211,000	300,000	109	111	HJ248	9.449	12.323	1.161	.630	.157	10.3
258,000	375,000	145	148	HJ252	10.236	13.386	1.299	.709	.197	13.7
267,000	395,000	153	156	HJ256	11.024	14.173	1.299	.709	.197	16.3
315,000	465,000	190	194	HJ260	11.811	15.236	1.358	.787	.197	20.2
360,000	540,000	240	245	HJ264	12.598	16.339	1.457	.827	.197	24.9

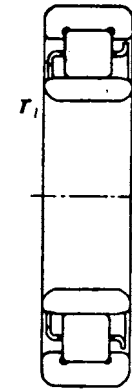

NU2

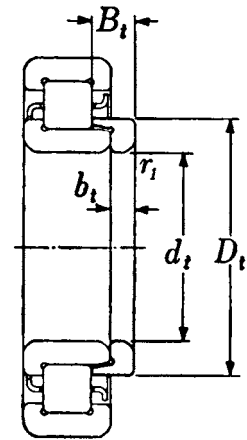

(NH2=NJ2+HJ2)

These figures may vary slightly according to cage type and type of bearing.



Units: INCHES
Millimeters

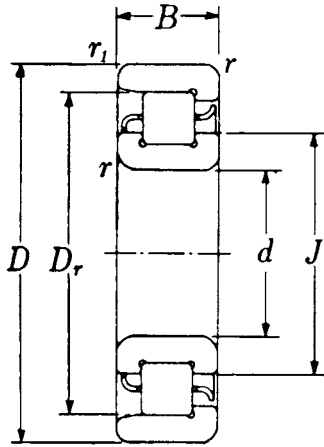

NF3

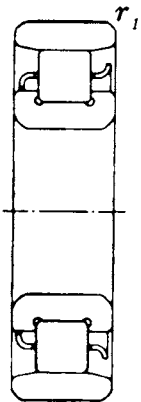

N3

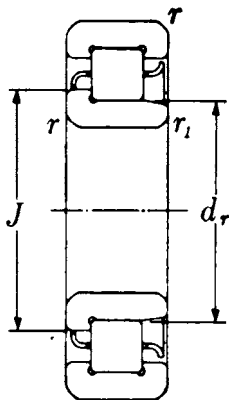

NJ3

CYLINDRICAL ROLLER BEARINGS

Bearing No.	Bore	O.D.	Width <i>B</i>	Fillet Radii		Outer Ring I.D. <i>D_r</i>	Inner Ring O.D. <i>d_r</i>	Shoulder Height <i>J</i>
	<i>d</i>	<i>D</i>		<i>r</i>	<i>r₁</i>			
304	.7874 20	2.0472 52	.5906 15	.059 1.5	.024 .6	1.7520 44.5	1.1220 28.5	1.252 31.8
305	.9843 25	2.4409 62	.6693 17	.059 1.5	.059 1.5	2.0866 53.0	1.3780 35.0	1.535 39.0
306	1.1811 30	2.8346 72	.7480 19	.059 1.5	.059 1.5	2.4409 62.0	1.6535 42.0	1.807 45.9
307	1.3780 35	3.1496 80	.8268 21	.079 2.0	.059 1.5	2.6850 68.2	1.8189 46.2	2.000 50.8
308	1.5748 40	3.5433 90	.9055 23	.079 2.0	.079 2.0	3.0512 77.5	2.1063 53.5	2.299 58.4
309	1.7717 45	3.9370 100	.9843 25	.079 2.0	.079 2.0	3.4055 86.5	2.3031 58.5	2.520 64.0
310	1.9685 50	4.3307 110	1.0630 27	.098 2.5	.098 2.5	3.7402 95.0	2.5591 65.0	2.795 71.0
311	2.1654 55	4.7244 120	1.1417 29	.098 2.5	.098 2.5	4.1142 104.5	2.7756 70.5	3.039 77.2
312	2.3622 60	5.1181 130	1.2205 31	.098 2.5	.098 2.5	4.4488 113.0	3.0315 77.0	3.315 84.2
313	2.5591 65	5.5118 140	1.2992 33	.098 2.5	.098 2.5	4.7835 121.5	3.2874 83.5	3.583 91.0
314	2.7559 70	5.9055 150	1.3780 35	.098 2.5	.098 2.5	5.1181 130.0	3.5433 90.0	3.858 98.0
315	2.9528 75	6.2992 160	1.4567 37	.098 2.5	.098 2.5	5.4921 139.5	3.7598 95.5	4.102 104.2
316	3.1496 80	6.6929 170	1.5354 39	.098 2.5	.098 2.5	5.7874 147.0	4.0551 103.0	4.402 111.8
317	3.3465 85	7.0866 180	1.6142 41	.118 3.0	.118 3.0	6.1417 156.0	4.2520 108.0	4.626 117.5
318	3.5433 90	7.4803 190	1.6929 43	.118 3.0	.118 3.0	6.4961 165.0	4.5276 115.0	4.921 125.0
319	3.7402 95	7.8740 200	1.7717 45	.118 3.0	.118 3.0	6.8307 173.5	4.7835 121.5	5.197 132.0
320	3.9370 100	8.4646 215	1.8504 47	.118 3.0	.118 3.0	7.3031 185.5	5.0984 129.5	5.531 140.5
321	4.1339 105	8.8583 225	1.9291 49	.118 3.0	.118 3.0	7.6772 195.0	5.3150 135.0	5.787 147.0
322	4.3307 110	9.4488 240	1.9685 50	.118 3.0	.118 3.0	8.1496 207.0	5.6299 143.0	6.122 155.5
324	4.7244 120	10.2362 260	2.1654 55	.118 3.0	.118 3.0	8.9976 226.0	6.0630 154.0	6.634 168.5
326	5.1181 130	11.0236 280	2.2835 58	.157 4.0	.157 4.0	9.5669 243.0	6.5748 167.0	7.165 182.0
328	5.5118 140	11.8110 300	2.4409 62	.157 4.0	.157 4.0	10.2362 260.0	7.0866 180.0	7.717 196.0
330	5.9055 150	12.5984 320	2.5591 65	.157 4.0	.157 4.0	10.9055 277.0	7.5984 193.0	8.268 210.0
332	6.2992 160	13.3858 340	2.6772 68	.157 4.0	.157 4.0	11.4961 292.0	8.1890 208.0	8.858 225.0
334	6.6929 170	14.1732 360	2.8346 72	.157 4.0	.157 4.0	12.2047 310.0	8.6614 220.0	9.370 238.0
336	7.0866 180	14.9606 380	2.9528 75	.157 4.0	.157 4.0	12.9134 328.0	9.1339 232.0	9.921 252.0
338	7.4803 190	15.7480 400	3.0709 78	.197 5.0	.197 5.0	13.5827 345.0	9.6457 245.0	10.433 265.0
340	7.8740 200	16.5354 420	3.1496 80	.197 5.0	.197 5.0	14.1732 360.0	10.2362 260.0	11.024 280.0
344	8.6614 220	18.1102 460	3.4646 88	.197 5.0	.197 5.0	15.5906 396.0	11.1811 284.0	12.087 307.0
348	9.4488 240	19.6850 500	3.7402 95	.197 5.0	.197 5.0	16.9291 430.0	12.2047 310.0	13.189 335.0
352	10.2362 260	21.2598 540	4.0157 102	.236 6.0	.236 6.0	18.2677 464.0	13.2283 336.0	14.252 362.0
356	11.0236 280	22.8346 580	4.2520 108	.236 6.0	.236 6.0	19.6063 498.0	14.2520 362.0	15.354 390.0

CYLINDRICAL ROLLER BEARINGS

Units: **INCHES**
Millimeters



Basic Load Ratings (lbs)		Weight (lbs)		Separate Thrust Collar No.	Thrust Collar Dimensions					Collar Weight (lbs)
Dynamic C	Static C_o	N3	NU3		d_t	D_t	B_t	b_t	r_i	
5,200	4,350	.328	.337	HJ304	.787	1.252	.295	.157	.024	.037
7,050	6,250	.518	.531	HJ305	.20	31.8	7.5	4	.6	.055
					.984	1.535	.315	.157	.059	
8,700	7,900	.772	.789	HJ306	.25	39.0	8.0	4	1.5	.086
					1.181	1.807	.374	.197	.059	
11,200	10,500	1.03	1.05	HJ307	.30	45.9	9.5	5	1.5	.123
					1.378	2.000	.433	.236	.059	
13,200	12,800	1.42	1.45	HJ308	.35	50.8	11.0	6	1.5	.183
					1.575	2.299	.492	.276	.079	
17,700	17,400	1.89	1.93	HJ309	.40	58.4	12.5	7	2.0	.218
					1.772	2.520	.492	.276	.079	
19,500	19,400	2.45	2.51	HJ310	.45	64.0	12.5	7	2.0	.313
					1.969	2.795	.551	.315	.098	
24,900	25,000	3.13	3.20	HJ311	.50	71.0	14.0	8	2.5	.401
					2.165	3.039	.591	.354	.098	
27,800	28,400	3.90	3.99	HJ312	.55	77.2	15.0	9	2.5	.485
					2.362	3.315	.610	.354	.098	
30,500	31,000	4.81	4.92	HJ313	.60	84.2	15.5	9	2.5	.617
					2.559	3.583	.669	.394	.098	
35,500	38,000	5.84	5.97	HJ314	.65	91.0	17.0	10	2.5	.728
					2.756	3.858	.689	.394	.098	
43,000	46,000	7.01	7.17	HJ315	.70	98.0	17.5	10	2.5	.882
					2.953	4.102	.728	.433	.098	
45,000	50,000	8.31	8.51	HJ316	.75	104.2	18.5	11	2.5	1.04
					3.150	4.402	.768	.433	.098	
50,500	55,500	9.79	10.0	HJ317	.80	111.8	19.5	11	2.5	1.23
					3.346	4.626	.807	.472	.118	
54,000	59,500	11.4	11.7	HJ318	.85	117.5	20.5	12	3.0	1.39
					3.543	4.921	.827	.472	.118	
61,500	70,000	13.2	13.5	HJ319	.90	125.0	21.0	12	3.0	1.68
					3.740	5.197	.886	.512	.118	
71,000	81,500	16.1	16.5	HJ320	.95	132.0	22.5	13	3.0	1.97
					3.937	5.531	.886	.512	.118	
81,000	94,000	22.1	22.5	HJ321	1.00	140.5	22.5	13	3.0	2.14
					4.134	5.787	.886	.512	.118	
90,500	105,000	25.8	26.5	HJ322	1.05	147.0	22.5	13	3.0	2.58
					4.331	6.122	.906	.551	.118	
107,000	124,000	33.3	34.2	HJ324	1.10	155.5	23.0	14	3.0	3.09
					4.724	6.634	.925	.551	.118	
126,000	150,000	39.2	40.1	HJ326	1.15	163.5	23.5	14	3.0	3.57
					5.118	7.165	.945	.551	.157	
139,000	168,000	48.1	49.2	HJ328	1.20	172.0	24.0	14	4.0	4.25
					5.512	7.717	1.024	.591	.157	
149,000	182,000	57.1	58.4	HJ330	1.25	180.0	25.0	15	4.0	5.22
					5.906	8.268	1.043	.591	.157	
157,000	197,000	67.5	69.0	HJ332	1.30	188.5	25.5	15	4.0	6.06
					6.299	8.858	1.102	.591	.157	
179,000	227,000	79.6	81.6	HJ334	1.35	197.0	26.0	15	4.0	7.17
					6.693	9.370	1.161	.630	.157	
203,000	260,000	92.4	94.6	HJ336	1.40	206.0	26.5	15	4.0	8.49
					7.087	9.921	1.201	.669	.157	
219,000	283,000	106	109	HJ338	1.45	215.0	27.0	16	4.0	9.81
					7.480	10.433	1.260	.709	.197	
219,000	286,000	120	123	HJ340	1.50	224.0	27.5	16	4.0	11.0
					7.874	11.024	1.299	.709	.197	
268,000	355,000	158	162	HJ344	1.55	233.0	28.0	16	4.0	15.5
					8.661	12.087	1.417	.787	.197	
320,000	440,000	201	206	HJ348	1.60	242.0	28.5	16	4.0	18.1
					9.449	13.189	1.555	.866	.197	
365,000	500,000	251	258	HJ352	1.65	251.0	29.0	17	4.0	25.1
					10.236	14.252	1.693	.945	.236	
410,000	570,000	306	313	HJ356	1.70	260.0	29.5	17	4.0	30.6
					11.024	15.354	1.811	1.024	.236	

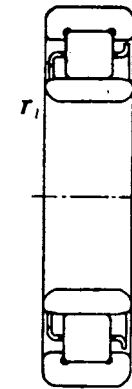

NU3

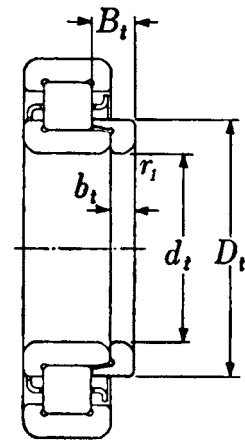

(NH3=NJ3+HJ3)

These figures may vary slightly according to cage type and type of bearing.



Units: INCHES
Millimeters

CYLINDRICAL ROLLER BEARINGS

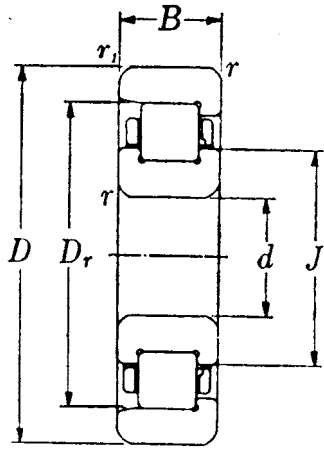

NF4

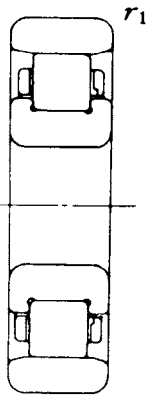

N4

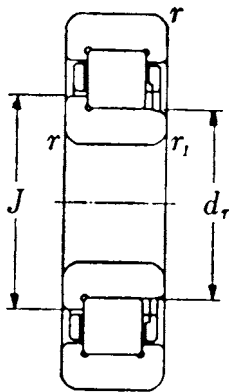

NJ4

Bearing No.	Bore	O.D.	Width	Fillet Radius		Outer Ring I.D.	Inner Ring O.D.	Shoulder Height
	<i>d</i>	<i>D</i>	<i>B</i>	<i>r</i>	<i>r₁</i>	<i>D_r</i>	<i>d_r</i>	<i>J</i>
406	1.1811 30	3.5433 90	.9055 23	.079 2.0		2.8740 73.0	1.7717 45.0	1.988 50.5
407	1.3780 35	3.9370 100	.9843 25	.079 2.0		3.2677 83.0	2.0866 53.0	2.323 59.0
408	1.5748 40	4.3307 110	1.0630 27	.098 2.5		3.6220 92.0	2.2835 58.0	2.551 64.8
409	1.7717 45	4.7244 120	1.1417 29	.098 2.5		3.9567 100.5	2.5394 64.5	2.827 71.8
410	1.9685 50	5.1181 130	1.2205 31	.098 2.5		4.3622 110.8	2.7874 70.8	3.102 78.8
411	2.1654 55	5.5118 140	1.2992 33	.098 2.5		4.6142 117.2	3.0394 77.2	3.354 85.2
412	2.3622 60	5.9055 150	1.3780 35	.098 2.5		5.0000 127.0	3.2677 83.0	3.614 91.8
413	2.5591 65	6.2992 160	1.4567 37	.098 2.5		5.3268 135.3	3.5157 89.3	3.878 98.5
414	2.7559 70	7.0866 180	1.6535 42	.118 3.0		5.9843 152.0	3.9370 100.0	4.350 110.5
415	2.9528 75	7.4803 190	1.7717 45	.118 3.0		6.3189 160.5	4.1142 104.5	4.567 116.0
416	3.1496 80	7.8740 200	1.8898 48	.118 3.0		6.6929 170.0	4.3307 110.0	4.803 122.0
417	3.3465 85	8.2677 210	2.0472 52	.157 4.0		6.9685 177.0	4.4488 113.0	4.961 126.0
418	3.5433 90	8.8583 225	2.1260 54	.157 4.0		7.5394 191.5	4.8622 123.5	5.394 137.0
419	3.7402 95	9.4488 240	2.1654 55	.157 4.0		7.9331 201.5	5.2559 133.5	5.787 147.0
420	3.9370 100	9.8425 250	2.2835 58	.157 4.0		8.3071 211.0	5.4724 139.0	6.043 153.5
421	4.1339 105	10.2362 260	2.3622 60	.157 4.0		8.6811 220.5	5.6890 144.5	6.280 159.5
422	4.3307 110	11.0236 280	2.5591 65	.157 4.0		9.2520 235.0	6.1024 155.0	6.732 171.0
424	4.7244 120	12.2047 310	2.8346 72	.197 5.0		10.2362 260.0	6.6929 170.0	7.402 188.0
426	5.1181 130	13.3858 340	3.0709 78	.197 5.0		11.2205 285.0	7.2835 185.0	8.071 205.0
428	5.5118 140	14.7132 374	3.2283 82	.197 5.0		11.8898 302.0	7.7953 198.0	8.622 219.0
430	5.9055 150	14.9606 380	3.3465 85	.197 5.0		12.4803 317.0	8.3858 213.0	9.213 234.0

CYLINDRICAL ROLLER BEARINGS

Units: **INCHES**
Millimeters



Basic Load Ratings (lbs)		Weight (lbs)		Separate Thrust Collar No.	Thrust Collar Dimensions					Collar Weight (lbs)
Dynamic C	Static C_o	N4	NU4		d_t	D_t	B_t	b_t	r_t	
14,100	12,400	1.75	1.79	HJ406	1.181	1.988	.453	.276	.079	.176
					30	50.5	11.5	7	2.0	
16,900	15,500	2.29	2.36	HJ407	1.378	2.323	.512	.315	.079	.265
					35	59.0	13.0	8	2.0	
21,500	20,000	3.02	3.09	HJ408	1.575	2.551	.512	.315	.098	.309
					40	64.8	13.0	8	2.5	
25,900	25,100	3.77	3.86	HJ409	1.772	2.827	.531	.315	.098	.386
					45	71.8	13.5	8	2.5	
31,000	30,500	4.70	4.81	HJ410	1.969	3.102	.571	.354	.098	.507
					50	78.8	14.5	9	2.5	
31,500	31,000	5.78	5.91	HJ411	2.165	3.354	.650	.394	.098	.639
					55	85.2	16.5	10	2.5	
37,500	38,000	6.97	7.14	HJ412	2.362	3.614	.650	.394	.098	.750
					60	91.8	16.5	10	2.5	
44,000	45,500	8.36	8.55	HJ413	2.559	3.878	.709	.433	.098	.926
					65	98.5	18.0	11	2.5	
54,500	58,000	12.2	12.5	HJ414	2.756	4.350	.787	.472	.118	1.33
					70	110.5	20.0	12	3.0	
59,000	61,500	14.5	14.8	HJ415	2.953	4.567	.846	.512	.118	1.57
					75	116.0	21.5	13	3.0	
67,500	71,000	17.0	17.4	HJ416	3.150	4.803	.866	.512	.118	1.72
					80	122.0	22.0	13	3.0	
75,000	78,500	20.2	20.7	HJ417	3.346	4.961	.945	.551	.157	1.94
					85	126.0	24.0	14	4.0	
84,000	90,000	24.0	24.7	HJ418	3.543	5.394	.945	.551	.157	2.31
					90	137.0	24.0	14	4.0	
90,000	99,500	28.4	29.1	HJ419	3.740	5.787	1.004	.591	.157	2.87
					95	147.0	25.5	15	4.0	
101,000	111,000	32.0	32.8	HJ420	3.937	6.043	1.063	.630	.157	3.31
					100	153.5	27.0	16	4.0	
112,000	125,000	35.7	36.6	HJ421	4.134	6.280	1.063	.630	.157	3.64
					105	159.5	27.0	16	4.0	
123,000	140,000	45.4	46.5	HJ422	4.331	6.732	1.161	.669	.157	4.63
					110	171.0	29.5	17	4.0	
151,000	173,000	62.2	63.7	HJ424	4.724	7.402	1.201	.669	.197	5.73
					120	188.0	30.5	17	5.0	
185,000	215,000	81.1	83.1	HJ426	5.118	8.071	1.260	.709	.197	7.28
					130	205.0	32.0	18	5.0	
197,000	230,000	95.2	97.7	HJ428	5.512	8.622	1.299	.709	.197	8.27
					140	219.0	33.0	18	5.0	
209,000	253,000	190	112	HJ430	5.906	9.213	1.437	.787	.197	10.40
					150	234.0	36.5	20	5.0	

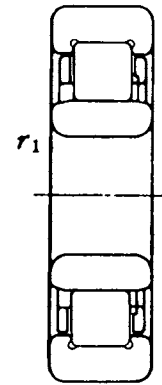

NU4

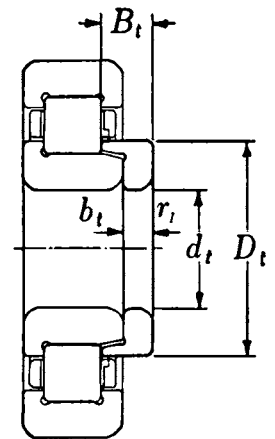

NH4=NJ4+HJ4

These figures may vary slightly according to cage type and type of bearing.



Units: INCHES
Millimeters

CYLINDRICAL ROLLER BEARINGS

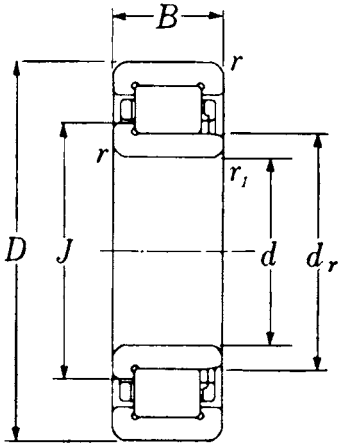

NJ22

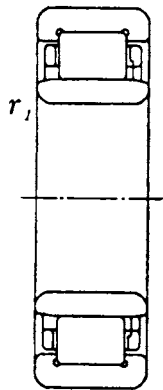

NU22

Bearing No.	Bore	O.D.	Width <i>B</i>	Fillet Radii		Inner Ring O.D. <i>d_r</i>	Shoulder Height <i>J</i>
	<i>d</i>	<i>D</i>		<i>r</i>	<i>r₁</i>		
2205	.9843 25	2.0472 52	.7087 18	.039 1.0	.024 .6	1.2598 32.0	1.378 35.0
2206	1.1811 30	2.4409 62	.7874 20	.039 1.0	.024 .6	1.5157 38.5	1.646 41.8
2207	1.3780 35	2.8346 72	.9055 23	.059 1.5	.024 .6	1.7244 43.8	1.874 47.6
2208	1.5748 40	3.1496 80	.9055 23	.059 1.5	.059 1.5	1.9685 50.0	2.134 54.2
2209	1.7717 45	3.3465 85	.9055 23	.059 1.5	.059 1.5	2.1654 55.0	2.323 59.0
2210	1.9685 50	3.5433 90	.9055 23	.059 1.5	.059 1.5	2.3780 60.4	2.543 64.6
2211	2.1654 55	3.9370 100	.9843 25	.079 2.0	.059 1.5	2.6181 66.5	2.787 70.8
2212	2.3622 60	4.3307 110	1.1024 28	.079 2.0	.079 2.0	2.8937 73.5	3.087 78.4
2213	2.5591 65	4.7244 120	1.2205 31	.079 2.0	.079 2.0	3.1339 79.6	3.339 84.8
2214	2.7559 70	4.9213 125	1.2205 31	.079 2.0	.079 2.0	3.3268 84.5	3.528 89.6
2215	2.9528 75	5.1181 130	1.2205 31	.079 2.0	.079 2.0	3.4843 88.5	3.701 94.0
2216	3.1496 80	5.5118 140	1.2992 33	.098 2.5	.098 2.5	3.7520 95.3	3.984 101.2
2217	3.3465 85	5.9055 150	1.4173 36	.098 2.5	.098 2.5	4.0079 101.8	4.260 108.2
2218	3.5433 90	6.2992 160	1.5748 40	.098 2.5	.098 2.5	4.2126 107.0	4.496 114.2
2219	3.7402 95	6.6929 170	1.6929 43	.098 2.5	.098 2.5	4.4685 113.5	4.764 121.0
2220	3.9370 100	7.0866 180	1.8110 46	.098 2.5	.098 2.5	4.7244 120.0	5.039 128.0
2222	4.3307 110	7.8740 200	2.0866 53	.098 2.5	.098 2.5	5.2165 132.5	5.571 141.5
2224	4.7244 120	8.4646 215	2.2835 58	.098 2.5	.098 2.5	5.6496 143.5	6.024 153.0
2226	5.1181 130	9.0551 230	2.5197 64	.118 3.0	.118 3.0	6.1417 156.0	6.516 165.5
2228	5.5118 140	9.8425 250	2.6772 68	.118 3.0	.118 3.0	6.6535 169.0	7.067 179.5
2230	5.9055 150	10.6299 270	2.8740 73	.118 3.0	.118 3.0	7.1654 182.0	7.598 193.0
2232	6.2992 160	11.4173 290	3.1496 80	.118 3.0	.118 3.0	7.6772 195.0	8.150 207.0
2234	6.6929 170	12.2047 310	3.3858 86	.157 4.0	.157 4.0	8.1890 208.0	8.681 220.5
2236	7.0866 180	12.5984 320	3.3858 86	.157 4.0	.157 4.0	8.5827 218.0	9.075 230.5
2238	7.4803 190	13.3858 340	3.6220 92	.157 4.0	.157 4.0	9.0945 231.0	9.626 244.5
2240	7.8740 200	14.1732 360	3.8583 98	.157 4.0	.157 4.0	9.6063 244.0	10.157 258.0

CYLINDRICAL ROLLER BEARINGS

Units: INCHES
Millimeters



Basic Load Ratings (lbs)		Weight (lbs)		Separate Thrust Collar No.	Thrust Collar Dimensions					Collar Weight (lbs)
Dynamic C	Static C ₀	NJ22	NU22		d _t	D _t	B _t	b _t	r _t	
5,650	5,550	.412	.401	HJ2205	.984 25	1.378 35.0	.295 7.5	.118 3.0	.024 .6	.033
7,850	8,050	.639	.631	HJ2206	1.181 30	1.646 41.8	.335 8.5	.157 4.0	.024 .6	.055
11,700	12,500	1.00	.974	HJ2207	1.378 35	1.874 47.6	.335 8.5	.157 4.0	.024 .6	.068
13,100	13,900	1.21	1.18	HJ2208	1.575 40	2.134 54.2	.374 9.5	.197 5.0	.059 1.5	.104
13,800	15,200	1.31	1.28	HJ2209	1.772 45	2.323 59.0	.374 9.5	.197 5.0	.059 1.5	.117
15,200	17,700	1.42	1.38	HJ2210	1.969 50	2.543 64.6	.374 9.5	.197 5.0	.059 1.5	.134
17,800	20,900	1.94	1.88	HJ2211	2.165 55	2.787 70.8	.433 11.0	.236 6.0	.059 1.5	.185
22,700	27,800	2.65	2.58	HJ2212	2.362 60	3.087 78.4	.433 11.0	.236 6.0	.079 2.0	.238
27,000	33,500	3.48	3.40	HJ2213	2.559 65	3.339 84.8	.453 11.5	.236 6.0	.079 2.0	.278
28,100	36,000	3.70	3.59	HJ2214	2.756 70	3.528 89.6	.492 12.5	.276 7.0	.079 2.0	.331
30,500	38,500	3.88	3.77	HJ2215	2.953 75	3.701 94.0	.492 12.5	.276 7.0	.079 2.0	.344
34,500	44,500	4.83	4.70	HJ2216	3.150 80	3.984 101.2	.531 13.5	.315 8.0	.098 2.5	.456
40,000	52,000	6.11	5.93	HJ2217	3.346 85	4.260 108.2	.551 14.0	.315 8.0	.098 2.5	.551
46,500	59,500	7.78	7.56	HJ2218	3.543 90	4.496 114.2	.630 16.0	.354 9.0	.098 2.5	.694
52,000	67,000	9.50	9.24	HJ2219	3.740 95	4.764 121.0	.650 16.5	.354 9.0	.098 2.5	.800
58,000	76,000	11.4	11.1	HJ2220	3.937 100	5.039 128.0	.709 18.0	.394 10.0	.098 2.5	1.01
75,000	99,500	16.4	16.0	HJ2222	4.331 110	5.571 141.5	.807 20.5	.433 11.0	.098 2.5	1.42
86,000	118,000	20.5	19.9	HJ2224	4.724 120	6.024 153.0	.866 22.0	.433 11.0	.098 2.5	1.69
89,000	126,000	25.6	24.9	HJ2226	5.118 130	6.516 165.5	.984 25.0	.433 11.0	.118 3.0	2.10
105,000	151,000	32.4	31.5	HJ2228	5.512 140	7.067 179.5	.984 25.0	.433 11.0	.118 3.0	2.51
123,000	180,000	40.8	39.7	HJ2230	5.906 150	7.598 193.0	1.043 26.5	.472 12.0	.118 3.0	3.06
142,000	211,000	52.0	50.7	HJ2232	6.299 160	8.150 207.0	1.102 28.0	.472 12.0	.118 3.0	3.73
161,000	242,000	64.2	62.4	HJ2234	6.693 170	8.681 220.5	1.142 29.0	.472 12.0	.157 4.0	4.25
167,000	257,000	66.8	65.0	HJ2236	7.087 180	9.075 230.5	1.142 29.0	.472 12.0	.157 4.0	4.50
187,000	290,000	81.1	78.9	HJ2238	7.480 190	9.626 244.5	1.240 31.5	.512 13.0	.157 4.0	5.56
208,000	325,000	97.4	94.8	HJ2240	7.874 200	10.157 258.0	1.339 34.0	.551 14.0	.157 4.0	6.59

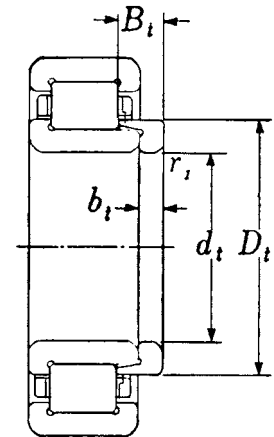

NH22=NJ22+HJ22

These figures may vary according to cage type and type of bearing.



Units: INCHES
Millimeters

CYLINDRICAL ROLLER BEARINGS

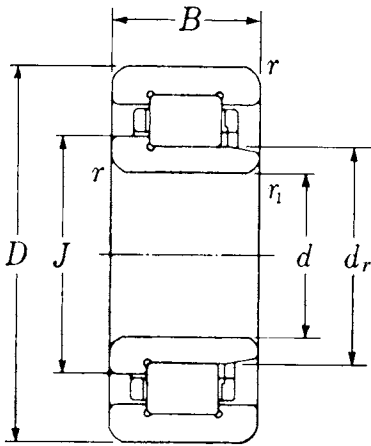

NJ23

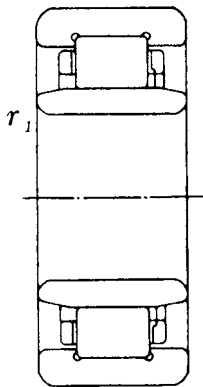

NU23

Bearing No.	Bore	O.D.	Width	Fillet Radii		Inner Ring O.D.	Shoulder Height
	<i>d</i>	<i>D</i>	<i>B</i>	<i>r</i>	<i>r₁</i>	<i>d_r</i>	<i>J</i>
2305	.9843 25	2.4409 62	.9449 24	.059 1.5	.059 1.5	1.3780 35.0	1.535 39.0
2306	1.1811 30	2.8346 72	1.0630 27	.059 1.5	.059 1.5	1.6535 42.0	1.807 45.9
2307	1.3780 35	3.1496 80	1.2205 31	.079 2.0	.059 1.5	1.8189 46.2	2.000 50.8
2308	1.5748 40	3.5433 90	1.2992 33	.079 2.0	.079 2.0	2.1063 53.5	2.299 58.4
2309	1.7717 45	3.9370 100	1.4173 36	.079 2.0	.079 2.0	2.3031 58.5	2.520 64.0
2310	1.9685 50	4.3307 110	1.5748 40	.098 2.5	.098 2.5	2.5591 65.0	2.795 71.0
2311	2.1654 55	4.7244 120	1.6929 43	.098 2.5	.098 2.5	2.7756 70.5	3.039 77.2
2312	2.3622 60	5.1181 130	1.8110 46	.098 2.5	.098 2.5	3.0315 77.0	3.315 84.2
2313	2.5591 65	5.5118 140	1.8898 48	.098 2.5	.098 2.5	3.2874 83.5	3.583 91.0
2314	2.7559 70	5.9055 150	2.0079 51	.098 2.5	.098 2.5	3.5433 90.0	3.858 98.0
2315	2.9528 75	6.2992 160	2.1654 55	.098 2.5	.098 2.5	3.7598 95.5	4.102 104.2
2316	3.1496 80	6.6929 170	2.2835 58	.098 2.5	.098 2.5	4.0551 103.0	4.402 111.8
2317	3.3465 85	7.0866 180	2.3622 60	.118 3.0	.118 3.0	4.2520 108.0	4.626 117.5
2318	3.5433 90	7.4803 190	2.5197 64	.118 3.0	.118 3.0	4.5276 115.0	4.921 125.0
2319	3.7402 95	7.8740 200	2.6378 67	.118 3.0	.118 3.0	4.7835 121.5	5.197 132.0
2320	3.9370 100	8.4646 215	2.8740 73	.118 3.0	.118 3.0	5.0984 129.5	5.531 140.5
2322	4.3307 110	9.4488 240	3.1496 80	.118 3.0	.118 3.0	5.6299 143.0	6.122 155.5
2324	4.7244 120	10.2362 260	3.3858 86	.118 3.0	.118 3.0	6.0630 154.0	6.634 168.5
2326	5.1181 130	11.0236 280	3.6614 93	.157 4.0	.157 4.0	6.5748 167.0	7.165 182.0
2328	5.5118 140	11.8110 300	4.0157 102	.157 4.0	.157 4.0	7.0866 180.0	7.717 196.0
2330	5.9055 150	12.5984 320	4.2520 108	.157 4.0	.157 4.0	7.5984 193.0	8.268 210.0
2332	6.2992 160	13.3858 340	4.4882 114	.157 4.0	.157 4.0	8.1890 208.0	8.858 225.0
2334	6.6929 170	14.1732 360	4.7244 120	.157 4.0	.157 4.0	8.6614 220.0	9.370 238.0
2336	7.0866 180	14.9606 380	4.9606 126	.157 4.0	.157 4.0	9.1339 232.0	9.921 252.0
2338	7.4803 190	15.7480 400	5.1969 132	.197 5.0	.197 5.0	9.6457 245.0	10.433 265.0
2340	7.8740 200	16.5354 420	5.4331 138	.197 5.0	.197 5.0	10.2362 260.0	11.024 280.0

CYLINDRICAL ROLLER BEARINGS

Units: INCHES
Millimeters



Basic Load Ratings (lbs)		Weight (lbs)		Separate Thrust Collar No.	Thrust Collar Dimensions					Collar Weight (lbs)
Dynamic C	Static C_o	NJ23	NU23		d_t	D_t	B_t	b_t	r_t	
10,300	10,100	.840	.816	HJ2305	.984 25	1.535 39.0	.354 9.0	.157 4	.059 1.5	.060
11,600	11,400	1.26	1.22	HJ2306	1.181 30	1.807 45.9	.453 11.5	.197 5	.059 1.5	.095
14,500	14,800	1.74	1.69	HJ2307	1.378 35	2.000 50.8	.551 14.0	.236 6	.059 1.5	.141
18,500	19,800	2.31	2.25	HJ2308	1.575 40	2.299 58.4	.571 14.5	.276 7	.079 2.0	.198
23,800	25,500	3.11	3.02	HJ2309	1.772 45	2.520 64.0	.591 15.0	.276 7	.079 2.0	.240
27,100	29,500	4.14	4.03	HJ2310	1.969 50	2.795 71.0	.669 17.0	.315 8	.098 2.5	.346
33,500	36,500	5.31	5.16	HJ2311	2.165 55	3.039 77.2	.728 18.5	.354 9	.098 2.5	.448
38,000	40,500	6.61	6.44	HJ2312	2.362 60	3.315 84.2	.748 19.0	.354 9	.098 2.5	.540
42,000	48,000	8.00	7.76	HJ2313	2.559 65	3.583 91.0	.787 20.0	.394 10	.098 2.5	.670
50,000	59,000	9.72	9.44	HJ2314	2.756 70	3.858 98.0	.807 20.5	.394 10	.098 2.5	.789
61,500	73,500	11.9	11.6	HJ2315	2.953 75	4.102 104.2	.846 21.5	.433 11	.098 2.5	.952
61,500	74,500	14.6	14.2	HJ2316	3.150 80	4.402 111.8	.906 23.0	.433 11	.098 2.5	1.13
71,000	86,000	16.9	16.4	HJ2317	3.346 85	4.626 117.5	.945 24.0	.472 12	.118 3.0	1.34
73,500	88,500	20.0	19.5	HJ2318	3.543 90	4.921 125.0	1.024 26.0	.472 12	.118 3.0	1.55
88,500	112,000	23.1	22.5	HJ2319	3.740 95	5.197 132.0	1.043 26.5	.512 13	.118 3.0	1.82
104,000	133,000	29.5	28.7	HJ2320	3.937 100	5.531 140.5	1.083 27.5	.512 13	.118 3.0	2.17
136,000	177,000	40.6	39.5	HJ2322	4.331 110	6.122 155.5	1.102 28.0	.551 14	.118 3.0	2.82
159,000	206,000	51.1	49.6	HJ2324	4.724 120	6.634 168.5	1.102 28.0	.551 14	.118 3.0	3.37
189,000	253,000	63.9	62.2	HJ2326	5.118 130	7.165 182.0	1.161 29.5	.551 14	.157 4.0	3.97
207,000	281,000	80.2	77.8	HJ2328	5.512 140	7.717 196.0	1.319 33.5	.591 15	.157 4.0	4.87
229,000	315,000	96.6	93.7	HJ2330	5.906 150	8.268 210.0	1.339 34.0	.591 15	.157 4.0	5.93
241,000	340,000	115	111	HJ2332	6.299 160	8.858 225.0	1.457 37.0	.591 15	.157 4.0	6.97
275,000	395,000	135	131	HJ2334	6.693 170	9.370 238.0	1.516 38.5	.630 16	.157 4.0	8.18
310,000	450,000	158	153	HJ2336	7.087 180	9.921 252.0	1.575 40.0	.669 17	.157 4.0	9.74
340,000	500,000	183	177	HJ2338	7.480 190	10.433 265.0	1.634 41.5	.709 18	.197 5.0	11.1
340,000	505,000	210	204	HJ2340	7.874 200	11.024 280.0	1.752 44.5	.709 18	.197 5.0	12.7

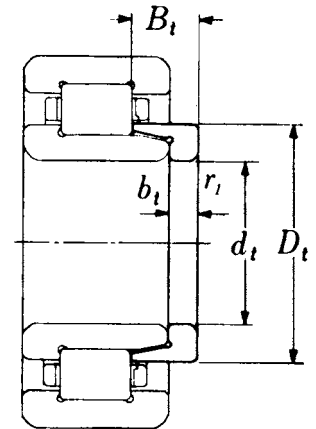

NH23=NJ23+HJ23

These figures may vary slightly according to cage type and type of bearing.



SERIES
NN30
NN30K

PRECISION
AND SUPER
PRECISION
GRADE

Suffix P5
• AFBMA RBEC 5 •
• ISO Class 5 •

Units: **INCHES**
Millimeters

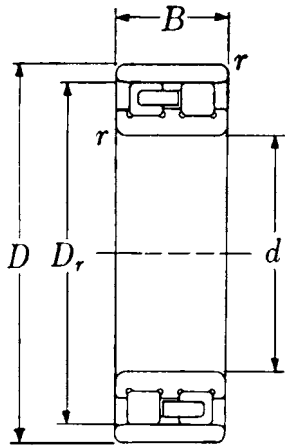

Cylindrical
Bore
NN30

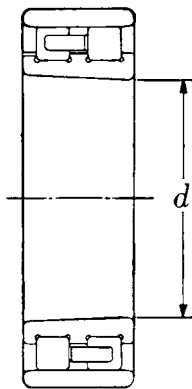

Tapered Bore
NN30K
Taper 1:12

DOUBLE ROW CYLINDRICAL ROLLER BEARINGS

Bearing No.		Bore	O.D.	Width	Fillet Radius	Outer Ring I.D.	Basic Load Ratings (lbs)		Weight (lbs)	
<i>NN30</i>	<i>NN30K</i>	<i>d</i>	<i>D</i>	<i>B</i>	<i>r</i>	<i>D_r</i>	<i>Dynamic C</i>	<i>Static C₀</i>	<i>NN30</i>	<i>NN30K</i>
NN3005	NN3005K	.9843	1.8504	.6299	.024	1.6260	5,800	6,750	.271	.262
		<small>25</small>	<small>47</small>	<small>16</small>	<small>.6</small>	<small>41.3</small>				
NN3006	NN3006K	1.1811	2.1654	.7480	.039	1.9094	6,900	8,350	.439	.425
		<small>30</small>	<small>55</small>	<small>19</small>	<small>1.0</small>	<small>48.5</small>				
NN3007	NN3007K	1.3780	2.4409	.7874	.039	2.1654	8,500	10,700	.569	.553
		<small>35</small>	<small>62</small>	<small>20</small>	<small>1.0</small>	<small>55.0</small>				
NN3008	NN3008K	1.5748	2.6772	.8268	.039	2.4016	9,750	12,500	.688	.668
		<small>40</small>	<small>68</small>	<small>21</small>	<small>1.0</small>	<small>61.0</small>				
NN3009	NN3009K	1.7717	2.9528	.9055	.039	2.6575	11,600	15,400	.893	.866
		<small>45</small>	<small>75</small>	<small>23</small>	<small>1.0</small>	<small>67.5</small>				
NN3010	NN3010K	1.9685	3.1496	.9055	.039	2.8543	11,900	16,300	1.00	.970
		<small>50</small>	<small>80</small>	<small>23</small>	<small>1.0</small>	<small>72.5</small>				
NN3011	NN3011K	2.1654	3.5433	1.0236	.059	3.1890	15,600	21,700	1.44	1.39
		<small>55</small>	<small>90</small>	<small>26</small>	<small>1.5</small>	<small>81.0</small>				
NN3012	NN3012K	2.3622	3.7402	1.0236	.059	3.3898	16,000	22,900	1.55	1.51
		<small>60</small>	<small>95</small>	<small>26</small>	<small>1.5</small>	<small>86.1</small>				
NN3013	NN3013K	2.5591	3.9370	1.0236	.059	3.5827	16,800	25,000	1.67	1.62
		<small>65</small>	<small>100</small>	<small>26</small>	<small>1.5</small>	<small>91.0</small>				
NN3014	NN3014K	2.7559	4.3307	1.1811	.059	3.9370	21,300	32,000	2.29	2.25
		<small>70</small>	<small>110</small>	<small>30</small>	<small>1.5</small>	<small>100.0</small>				
NN3015	NN3015K	2.9528	4.5276	1.1811	.059	4.1339	21,700	33,500	2.51	2.45
		<small>75</small>	<small>115</small>	<small>30</small>	<small>1.5</small>	<small>105.0</small>				
NN3016	NN3016K	3.1496	4.9213	1.3386	.059	4.4488	26,000	40,000	3.35	3.24
		<small>80</small>	<small>125</small>	<small>34</small>	<small>1.5</small>	<small>113.0</small>				
NN3017	NN3017K	3.3465	5.1181	1.3386	.059	4.6457	27,400	43,500	3.55	3.44
		<small>85</small>	<small>130</small>	<small>34</small>	<small>1.5</small>	<small>118.0</small>				
NN3018	NN3018K	3.5433	5.5118	1.4567	.079	5.0000	32,000	51,000	4.56	4.43
		<small>90</small>	<small>140</small>	<small>37</small>	<small>2.0</small>	<small>127.0</small>				
NN3019	NN3019K	3.7402	5.7087	1.4567	.079	5.1969	33,000	53,500	4.78	4.63
		<small>95</small>	<small>145</small>	<small>37</small>	<small>2.0</small>	<small>132.0</small>				
NN3020	NN3020K	3.9370	5.9055	1.4567	.079	5.3937	34,500	57,500	4.98	4.83
		<small>100</small>	<small>150</small>	<small>37</small>	<small>2.0</small>	<small>137.0</small>				
NN3021	NN3021K	4.1339	6.2992	1.6142	.098	5.7480	44,500	72,500	6.37	6.17
		<small>105</small>	<small>160</small>	<small>41</small>	<small>2.5</small>	<small>146.0</small>				
NN3022	NN3022K	4.3307	6.6929	1.7717	.098	6.1024	51,500	84,500	8.11	7.85
		<small>110</small>	<small>170</small>	<small>45</small>	<small>2.5</small>	<small>155.0</small>				
NN3024	NN3024K	4.7244	7.0866	1.8110	.098	6.4961	52,500	88,000	8.77	8.49
		<small>120</small>	<small>180</small>	<small>46</small>	<small>2.5</small>	<small>165.0</small>				
NN3026	NN3026K	5.1181	7.8740	2.0472	.098	7.1654	64,000	107,000	13.1	12.7
		<small>130</small>	<small>200</small>	<small>52</small>	<small>2.5</small>	<small>182.0</small>				
NN3028	NN3028K	5.5118	8.2677	2.0866	.098	7.5591	67,000	116,000	14.2	13.8
		<small>140</small>	<small>210</small>	<small>53</small>	<small>2.5</small>	<small>192.0</small>				
NN3030	NN3030K	5.9055	8.8583	2.2047	.098	8.1102	75,000	132,000	17.2	16.7
		<small>150</small>	<small>225</small>	<small>56</small>	<small>2.5</small>	<small>206.0</small>				
NN3032	NN3032K	6.2992	9.4488	2.3622	.098	8.6220	84,000	149,000	19.7	19.0
		<small>160</small>	<small>240</small>	<small>60</small>	<small>2.5</small>	<small>219.0</small>				
NN3034	NN3034K	6.6929	10.2362	2.6378	.098	9.2913	99,000	174,000	27.8	26.9
		<small>170</small>	<small>260</small>	<small>67</small>	<small>2.5</small>	<small>236.0</small>				
NN3036	NN3036K	7.0866	11.0236	2.9134	.098	10.0394	127,000	224,000	36.6	35.5
		<small>180</small>	<small>280</small>	<small>74</small>	<small>2.5</small>	<small>255.0</small>				
NN3038	NN3038K	7.4803	11.4173	2.9528	.098	10.4331	130,000	233,000	38.6	37.5
		<small>190</small>	<small>290</small>	<small>75</small>	<small>2.5</small>	<small>265.0</small>				
NN3040	NN3040K	7.8740	12.2047	3.2283	.098	11.1024	147,000	262,000	47.6	47.2
		<small>200</small>	<small>310</small>	<small>82</small>	<small>2.5</small>	<small>282.0</small>				
NN3044	NN3044K	8.6614	13.3858	3.5433	.118	12.2047	183,000	330,000	64.6	62.6
		<small>220</small>	<small>340</small>	<small>90</small>	<small>3.0</small>	<small>310.0</small>				
NN3048	NN3048K	9.4488	14.1732	3.6220	.118	12.9921	192,000	360,000	72.3	70.1
		<small>240</small>	<small>360</small>	<small>92</small>	<small>2.0</small>	<small>330.0</small>				
NN3052	NN3052K	10.2362	15.7480	4.0945	.157	14.3307	239,000	450,000	104	101
		<small>260</small>	<small>400</small>	<small>104</small>	<small>4.0</small>	<small>364.0</small>				
NN3056	NN3056K	11.0236	16.5354	4.1732	.157	15.1181	243,000	465,000	113	109
		<small>280</small>	<small>420</small>	<small>106</small>	<small>4.0</small>	<small>384.0</small>				
NN3060	NN3060K	11.8110	18.1102	4.6457	.157	16.4567	299,000	575,000	156	151
		<small>300</small>	<small>460</small>	<small>118</small>	<small>4.0</small>	<small>418.0</small>				
NN3064	NN3064K	12.5984	18.8976	4.7638	.157	17.2441	305,000	600,000	168	163
		<small>320</small>	<small>480</small>	<small>121</small>	<small>4.0</small>	<small>438.0</small>				

Note: The d dimension for the tapered bore is measured from the side of the bearing with the smallest bore dimension.

Inch Series

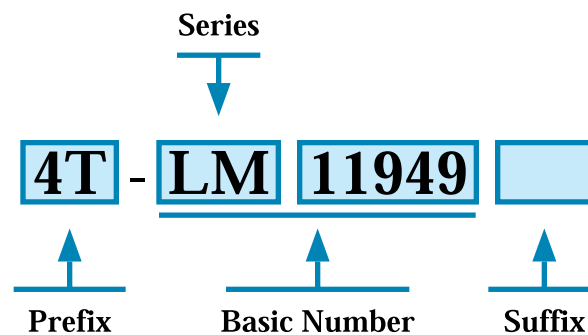

ISO Series

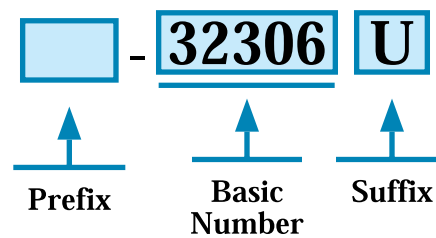

1. PREFIX

ET:	NTN Endurance tapered roller bearings, case hardened material
4T:	NTN 4-Top tapered roller bearings, case hardened material
E:	Case hardened steel
T:	Internationally interchangeable dimensions

2. SERIES

H:	Heavy
HH:	Heavier than heavy
HM:	Heavy-medium
L:	Light
LM:	Light medium
M:	Medium
ISO:	Metric series 320X, 302, 322, 303 and 323

3. SUFFIX

A:	Different bore, O.D., width or radius from basic part number
PK:	Class K for J-Line
PXn:	Special tolerance, n; from 1 onward
S:	Different bore, OD, width or radius from basic part number
U:	ISO series; internationally interchangeable through hardened steel
W:	Slot or keyway
X:	Different bore, O.D., width or radius from basic part number
-0:	AFBMA class 0
-00:	AFBMA class 00
-2:	AFBMA class 2
-3:	AFBMA class 3
-4:	AFBMA class 4



Units: **INCHES**
Millimeters

TAPERED ROLLER BEARINGS

Cone Number	Bore	Cone Width	Max. shaft fillet radius	Cup Number	O.D.	Cup Width	Max. housing fillet radius	Overall Width
	<i>d</i>	<i>B</i>	<i>R</i>		<i>D</i>	<i>b</i>	<i>r</i>	<i>T</i>
4T-335 SERIES								
4T-335	1.3750 34.925	.8820 22.403	.03 .6	4T-332	3.1496 80.000	.7018 17.826	.05 1.3	.8268 21.000
4T-336	1.6250 41.275	.8820 22.403	.03 .6	4T-332A	3.1496 80.000	.8268 21.000	.09 2.3	.9518 24.176
4T-339	1.3780 35.000	.8820 22.403	.03 .6					
4T-342	1.6250 41.275	.8820 22.403	.14 2.5					
4T-342A	1.6250 41.275	1.1802 29.977	.14 2.5					
4T-342S	1.6880 42.875	.8820 22.403	.14 2.5					
4T-344A	1.5748 40.000	.8820 22.403	.03 .6					
4T-355 SERIES								
4T-355	1.7500 44.450	.8540 21.692	.09 2.3	4T-352	3.5480 90.119	.8586 21.808	.09 2.3	.9055 23.000
4T-355X	1.7500 44.450	.8540 21.692	.14 2.5	4T-354A	3.3465 85.000	.6875 17.462	.05 1.3	.8125 20.638
4T-359A	1.8125 46.038	.8540 21.692	.14 2.5	4T-354X	3.3465 85.000	.6875 17.462	.06 1.5	.8125 20.638
4T-359S	1.8125 46.038	.8540 21.692	.09 2.3					
4T-365 SERIES								
4T-366	1.9685 50.000	.8750 22.225	.09 2.3	4T-362	3.5433 90.000	.6250 15.875	.08 2.0	.7874 20.000
4T-368	2.0000 50.800	.8750 22.225	.06 1.0	4T-362A	3.5000 88.900	.6501 16.513	.05 1.3	.8125 20.638
4T-368A	2.0000 50.800	.8750 22.225	.14 2.5	4T-363	3.5433 90.000	.7874 20.000	.03 .8	.7874 20.000
4T-368S	2.0312 51.592	.8750 22.225	.08 1.5					
4T-369A	1.8750 47.625	.8750 22.225	.14 2.5					
4T-369S	1.8750 47.625	.8750 22.225	.09 2.3					
4T-370A	2.0000 50.800	.8750 22.225	.20 4.0					
4T-385 SERIES								
4T-385	2.1654 55.000	.8640 21.946	.09 2.3	4T-382	3.8750 98.425	.7018 17.826	.03 .8	.8268 21.000
* 4T-385A	2.0000 50.800	.8640 21.946	.09 2.3	4T-382A	3.8125 96.838	.6250 15.875	.03 .8	.8268 21.000
4T-385X	2.1654 55.000	.8640 21.946	.14 2.5	4T-382S	3.8125 96.838	.7982 20.275	.09 2.3	1.0000 25.400
4T-386A	1.8750 47.625	.8640 21.946	.03 .6	4T-383A	3.9370 100.000	.7018 17.826	.08 2.0	.8268 21.000
4T-387	2.2500 57.150	.8640 21.946	.09 2.3					
4T-387A	2.2500 57.150	.8640 21.946	.14 2.5					
4T-387AS	2.2500 57.150	.8640 21.946	.20 4.0					
4T-387S	2.2500 57.150	.8640 21.946	.03 .6					
4Y-388A	2.2650 57.531	.8640 21.946	.14 2.5					
4T-389A	2.1250 53.975	.8640 21.946	.03 .6					
4T-395 SERIES								
4T-390	2.2500 57.150	.8660 21.996	.09 2.3	4T-393	4.3307 110.000	1.0630 27.000	.03 .8	1.0630 27.000
4T-395	2.5000 63.500	.8660 21.996	.14 2.5	4T-394A	4.3307 110.000	.7411 18.824	.05 1.3	.8661 22.000
4T-395A	2.6250 66.675	.8660 21.996	.03 .6	4T-394AS	4.3307 110.000	.7411 18.824	.13 3.3	.8661 22.000
4T-395S	2.6250 66.675	.8660 21.996	.14 2.5					
* 4T-396	1.9685 50.000	.8660 21.996	.03 .6					
4T-399A	2.6875 68.262	.8660 21.996	.09 2.3					
4T-399AS	2.6875 68.262	.8660 21.996	.20 4.0					

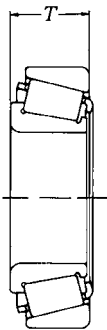
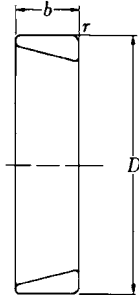
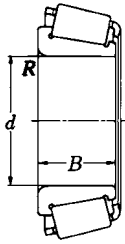

These maximum fillet radii will be cleared by the cone or cup radii.

* 0.6 in. (1.5 mm) front radius

TAPERED ROLLER BEARINGS

Units: INCHES
Millimeters



Cone Number	Bore	Cone Width	Max. shaft fillet radius	Cup Number	O.D.	Cup Width	Max. housing fillet radius	Overall Width
	<i>d</i>	<i>B</i>	<i>R</i>		<i>D</i>	<i>b</i>	<i>r</i>	<i>T</i>
4T-415 SERIES								
4T-418	1.5000 38.100	1.1450 29.083	.14 2.5	4T-412	3.2500 82.550	1.1875 30.162	.13 3.3	1.3750 34.925
4T-420	1.5748 40.000	1.1450 29.083	.14 2.5	4T-414	3.4843 88.500	.8750 22.225	.06 1.5	1.0625 26.988
4T-435 SERIES								
4T-438	1.7500 44.450	1.1772 29.901	.14 2.5	4T-432A	3.7500 95.250	.8750 22.225	.03 .8	1.0938 27.783
4T-443	1.2500 31.750	1.1772 29.901	.03 .6					
4T-455 SERIES								
4T-455	2.0000 50.800	1.1542 29.317	.03 .6	4T-453	4.2500 107.950	1.0630 27.000	.03 .8	1.0943 27.795
4T-461	1.6870 42.850	1.1542 29.317	.03 .6	4T-453A	4.2500 107.950	.8750 22.225	.03 .8	1.0938 27.783
4T-462	2.2500 57.150	1.1542 29.317	.09 2.3	4T-453X	4.1250 104.775	.9687 24.605	.13 3.3	1.1875 30.162
4T-467	1.8750 47.625	1.1542 29.317	.03 .6	4T-454	4.3307 110.000	1.0630 27.000	.08 2.0	1.0943 27.795
4T-469	2.2500 57.150	1.1542 29.317	.14 2.5					
4T-475 SERIES								
4T-480	2.6875 68.262	1.1420 29.007	.14 2.5	4T-472	4.7244 120.000	.9542 24.237	.08 2.0	1.1730 29.794
4T-482	2.7500 69.850	1.1420 29.007	.14 2.5	4T-472A	4.7244 120.000	.9230 23.444	.13 3.3	1.1418 29.002
4T-483	2.5000 63.500	1.1420 29.007	.14 2.5	4T-472X	4.8750 123.825	.9687 24.605	.13 3.3	1.1875 30.162
4T-484	2.7500 70.000	1.1420 29.007	.08 1.5					
4T-495 SERIES								
4T-495	3.2500 82.550	1.1720 29.769	.14 2.5					
4T-495A	3.0000 76.200	1.1720 29.769	.14 2.5	4T-492A	5.2500 133.350	.8750 22.225	.13 3.3	1.1875 30.162
4T-495AX	3.0000 76.200	1.1720 29.769	.25 6.4	4T-493	5.3750 136.525	.8750 22.225	.13 3.3	1.1875 30.162
4T-496	3.1875 80.962	1.1720 29.769	.14 2.5					
4T-497	3.3750 85.725	1.1720 29.769	.14 2.5					
4T-498	3.3125 84.138	1.1720 29.769	.14 2.5					
4T-525 SERIES								
4T-526	1.6250 41.275	1.4200 36.068	.14 2.5	4T-522	4.0000 101.600	1.0625 26.988	.13 3.3	1.3750 34.925
4T-527	1.7500 44.450	1.4200 36.068	.14 2.5					
4T-528	1.8750 47.625	1.4200 36.068	.14 2.5					
4T-529	2.0000 50.800	1.4200 36.068	.03 .6					
4T-535 SERIES								
4T-535	1.7500 44.450	1.4550 36.957	.14 2.5	4T-532A	4.3750 111.125	1.1875 30.162	.13 3.3	1.5000 38.100
4T-536	1.8750 47.625	1.4550 36.957	.14 2.5	4T-532X	4.2500 107.950	1.1250 28.575	.13 3.3	1.4375 36.512
4T-537	2.0000 50.800	1.4550 36.957	.14 2.5					
4T-539	2.1250 53.975	1.4550 36.957	.14 2.5					
4T-539A	2.1250 53.975	1.4550 36.957	.22 5.5					
4T-543	1.5748 40.000	1.4550 36.957	.14 2.5					

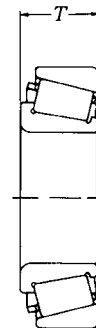
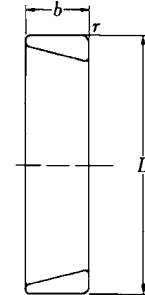
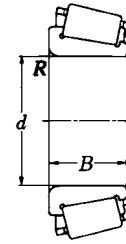

These maximum fillet radii will be cleared by the cone or cup radii.



Units: **INCHES**
Millimeters

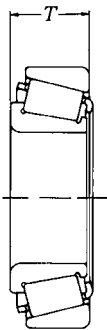
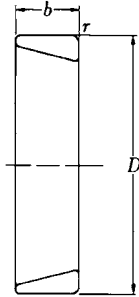
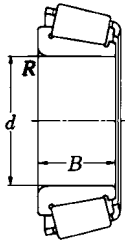

TAPERED ROLLER BEARINGS

Cone Number	Bore	Cone Width	Max. shaft fillet radius	Cup Number	O.D.	Cup Width	Max. housing fillet radius	Overall Width
	<i>d</i>	<i>B</i>	<i>R</i>		<i>D</i>	<i>b</i>	<i>r</i>	<i>T</i>
4T-555 SERIES								
4T-555S	2.2500 57.150	1.4440 36.678	.14 2.5	4T-552	4.8750 123.825	1.3125 33.338	.13 3.3	1.5000 38.100
4T-557A	2.3750 60.325	1.4440 36.678	.31 6.0	4T-552A	4.8750 123.825	1.1875 30.162	.13 3.3	1.5000 38.100
4T-557S	2.1250 53.975	1.4440 36.678	.14 2.5	4T-553A	4.9213 125.000	1.1875 30.162	.13 3.3	1.5000 38.100
4T-559	2.5000 63.500	1.4440 36.678	.14 2.5	4T-553X	4.8125 122.238	1.1875 30.162	.13 3.3	1.5000 38.100
4T-560	2.6250 66.675	1.4440 36.678	.14 2.5					
4T-565 SERIES								
4T-567	2.8750 73.025	1.4240 36.170	.14 2.5	4T-563	5.0000 127.000	1.1250 28.575	.13 3.3	1.4375 36.512
4T-575 SERIES								
4T-575	3.0000 76.200	1.4212 36.098	.14 2.5	4T-572	5.5115 139.992	1.1250 28.575	.13 3.3	1.4375 36.513
4T-575S	3.0000 76.200	1.4212 36.098	.27 6.8	4T-572X	5.5000 139.700	1.1250 28.575	.13 3.3	1.4375 36.513
4T-576	2.8750 73.025	1.4212 36.098	.14 2.5					
4T-577	2.9375 74.612	1.4212 36.098	.14 2.5					
4T-580	3.2500 82.550	1.4212 36.098	.14 2.5					
4T-581	3.1875 80.962	1.4212 36.098	.14 2.5					
4T-582	3.2500 82.550	1.4212 36.098	.27 6.8					
4T-595 SERIES								
4T-593	3.5000 88.900	1.4300 36.322	.14 3.5	4T-592	6.0000 152.400	1.3125 33.338	.13 3.3	1.5625 39.688
4T-593A	3.5000 88.900	1.4300 36.322	.25 6.4	4T-592A	6.0000 152.400	1.1875 30.162	.13 3.3	1.5625 39.688
4T-594	3.7500 95.250	1.4300 36.322	.14 3.5	4T-592XS	5.8125 147.638	1.0312 26.192	.13 3.3	1.4062 35.717
4T-594A	3.7500 95.250	1.4300 36.322	.20 4.0					
4T-595	3.2500 82.550	1.4300 36.322	.14 3.5					
4T-596	3.3750 85.723	1.4300 36.322	.14 3.5					
4T-598	3.6250 92.075	1.4300 36.322	.14 3.5					
4T-598A	3.6250 92.075	1.4300 36.322	.25 6.4					
4T-615 SERIES								
4T-620	1.5625 39.688	1.6250 41.275	.03 .6	4T-612	4.7500 120.650	1.2500 31.750	.13 3.3	1.6250 41.275
4T-621	2.1250 53.975	1.6250 41.275	.14 3.5					
4T-623	2.2500 57.150	1.6250 41.275	.14 3.5					
4T-635 SERIES								
4T-635	2.2500 57.150	1.6250 41.275	.14 2.5	4T-632	5.3750 136.525	1.2500 31.750	.13 3.3	1.6250 41.275
4T-639	2.5000 63.500	1.6250 41.275	.14 2.5	4T-633	5.1250 130.175	1.2500 31.750	.13 3.3	1.6250 41.275
4T-643	2.7500 69.850	1.6250 41.275	.14 2.5					
4T-645	2.8125 71.438	1.6250 41.275	.25 6.4					

These maximum fillet radii will be cleared by the cone or cup radii.

TAPERED ROLLER BEARINGS

Units: **INCHES**
Millimeters



Cone Number	Bore	Cone Width	Max. shaft fillet radius	Cup Number	O.D.	Cup Width	Max. housing fillet radius	Overall Width
	<i>d</i>	<i>B</i>	<i>R</i>		<i>D</i>	<i>b</i>	<i>r</i>	<i>T</i>
4T-655 SERIES								
4T-659	3.0000	1.6250	.14	4T-652	6.0000	1.2500	.13	1.6250
	76.200	41.275	2.5		152.400	31.750	3.3	41.275
4T-665	3.3750	1.6250	.14					
	85.725	41.275	2.5					
4T-665A	3.3750	1.6250	.25					
	85.725	41.275	6.4					
4T-662	3.1875	1.5000	.14	4T-652	6.0000	1.2500	.13	1.5000
	80.962	38.100	2.5		152.400	31.750	3.3	38.100
				4T-653	5.7500	1.2500	.13	1.5000
					146.050	31.750	3.3	38.100
4T-675 SERIES								
4T-681	3.6250	1.6250	.14	4T-672	6.6250	1.1875	.13	1.6250
	92.075	41.275	2.5		168.275	30.162	3.3	41.275
4T-681A	3.6250	1.6250	.25					
	92.075	41.275	6.4					
4T-683	3.7500	1.6250	.14					
	95.250	41.275	2.5					
4T-683XA	3.7500	1.6250	.20					
	95.250	41.275	4.0					
4T-685	3.8750	1.6250	.14					
	98.425	41.275	2.5					
4T-687	4.0000	1.6250	.14					
	101.600	41.275	2.5					
4T-745 SERIES								
4T-745A	2.7500	1.8375	.14	4T-742	5.9090	1.4375	.13	1.7500
	69.850	46.672	2.5		150.089	36.512	3.3	44.450
4T-748	3.1496	1.8375	.12	4T-743	5.9055	1.3780	.13	1.7502
	80.000	46.672	2.5		150.000	35.000	3.3	44.455
4T-749	3.3475	1.8375	.14					
	85.026	46.672	2.5					
4T-749A	3.2500	1.8375	.14					
	82.550	46.672	2.5					
4T-749S	3.3475	1.8375	.20					
	85.026	46.672	4.0					
4T-750A	3.2500	1.8375	.27					
	82.550	46.672	6.8					
4T-755 SERIES								
4T-756A	3.1250	1.9000	.31	4T-752	6.3750	1.5000	.13	1.8750
	79.375	48.260	6.0		161.925	38.100	3.3	47.625
4T-759	3.5000	1.9000	.14					
	88.900	48.260	2.5					
4T-760	3.5625	1.9000	.14					
	90.488	48.260	2.5					
4T-766	3.5000	1.9000	.28					
	88.900	48.260	7.0					
4T-795 SERIES								
4T-797	5.1181	1.8750	.14	4T-792	8.1250	1.3750	.13	1.8750
	130.000	47.625	2.5		206.375	34.925	3.3	47.625
4T-855 SERIES								
4T-855	3.5000	2.2650	.31	4T-854	7.5000	1.7500	.13	2.2500
	88.900	57.531	6.0		190.500	44.450	3.3	57.150
4T-857	3.6250	2.2650	.31					
	92.075	57.531	6.0					
4T-861	4.0000	2.2650	.31					
	101.600	57.531	6.0					
4T-864	3.7500	2.2650	.31					
	95.250	57.531	6.0					
4T-866	3.8750	2.2650	.14					
	98.425	57.531	2.5					
4T-869	3.4375	2.2650	.31					
	87.312	57.531	6.0					
4T-935 SERIES								
4T-936	4.2500	2.6250	.31	4T-932	8.3750	2.1250	.13	2.6250
	107.950	66.675	6.0		212.725	53.975	3.3	66.675
4T-938	4.5000	2.6250	.28					
	114.300	66.675	7.0					

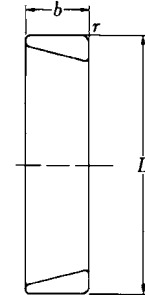
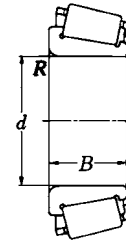

These maximum fillet radii will be cleared by the cone or cup radii.



Units: **INCHES**
Millimeters

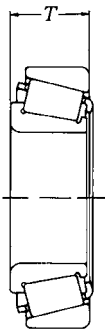
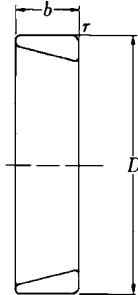
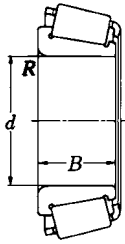

TAPERED ROLLER BEARINGS

Cone Number	Bore	Cone Width	Max. shaft fillet radius	Cup Number	O.D.	Cup Width	Max. housing fillet radius	Overall Width
	<i>d</i>	<i>B</i>	<i>R</i>		<i>D</i>	<i>b</i>	<i>r</i>	<i>T</i>
4T-1300 SERIES								
4T-1380	.8750 22.225	.7940 20.168	.06 1.0	4T-1328	2.0625 52.388	.5625 14.288	.06 1.5	.7625 19.368
4T-1700 SERIES								
4T-1755	.8750 22.225	.7810 19.837	.05 1.3	4T-1729	2.2400 56.896	.6250 15.875	.05 1.3	.7625 19.368
4T-1779	.9375 23.812	.7810 19.837	.03 .6	4T-1729X	2.2400 56.896	.6250 15.875	.06 1.5	.7625 19.368
4T-1780	1.0000 25.400	.7810 19.837	.03 .6					
4T-1900 SERIES								
4T-1986	1.0000 25.400	.7620 19.355	.05 1.3	4T-1922	2.2500 57.150	.6250 15.875	.06 1.5	.7813 19.845
4T-1988	1.1250 28.575	.7620 19.355	.14 2.5					
4T-2500 SERIES								
4T-2580	1.2500 31.750	.9983 25.357	.03 .8	4T-2523	2.7500 69.850	.7500 19.050	.05 1.3	.9375 23.812
4T-2585	1.3125 33.338	.9983 25.357	.14 2.5					
4T-2600 SERIES								
4T-2690	1.1562 29.367	1.0013 25.433	.14 2.5	4T-2631	2.6150 66.421	.7500 19.050	.05 1.3	.9375 23.812
4T-2700 SERIES								
4T-2776	1.5000 38.100	1.0100 25.654	.17 4.3	4T-2720	3.0000 76.200	.7500 19.050	.13 3.3	.9375 23.812
4T-2777	1.5000 38.100	1.0100 25.654	.22 5.5	4T-2729	3.0000 76.200	.7500 19.050	.03 .8	.9375 23.812
4T-2780	1.4365 36.487	1.0100 25.654	.06 1.5	4T-2735X	2.8750 73.025	.7500 19.050	.03 .8	.9375 23.812
4T-2788	1.5000 38.100	1.0100 25.654	.14 2.5					
4T-2789	1.5625 39.688	1.0100 25.654	.14 2.5					
4T-2790	1.3125 33.338	1.0100 25.654	.06 1.0					
4T-2793	1.3750 34.925	1.0100 25.654	.03 .6					
4T-2794	1.4365 36.487	1.0100 25.654	.14 2.5					
4T-2796	1.3750 34.925	1.0100 25.654	.14 2.5					
4T-2900 SERIES								
4T-2984	1.8125 46.038	1.0082 25.608	.14 2.5	4T-2924	3.3464 85.000	.8125 20.637	.05 1.3	1.0000 25.400
4T-3100 SERIES								
4T-3193	1.2500 31.750	1.1810 29.997	.14 2.5	4T-3120	2.8593 72.626	.9375 23.812	.13 3.3	1.1875 30.162
4T-3196	1.3125 33.338	1.1810 29.997	.14 2.5					
4T-3300 SERIES								
4T-3379	1.3750 34.925	1.1965 30.391	.14 2.5	4T-3320	3.1562 80.167	.9375 23.812	.13 3.3	1.1563 29.370
4T-3384	1.6250 41.275	1.1965 30.391	.03 .6	4T-3325	*3.1496 80.000	.9375 23.812	.13 3.3	1.1563 29.370
4T-3386	1.5625 39.688	1.1965 30.391	.03 .6					
4T-3400 SERIES								
4T-3478	1.3750 34.925	1.1721 29.771	.14 2.5	4T-3420	3.1250 79.375	.9375 23.812	.13 3.3	1.1563 29.370
4T-3479	1.4375 36.512	1.1721 29.771	.03 .6					
4T-3482	1.3750 34.925	1.1721 29.771	.03 .6					
4T-3490	1.5000 38.100	1.1721 29.771	.14 2.5					

These maximum fillet radii will be cleared by the cone or cup radii.

* Tolerance +.0000 to -.0010 in (+0 to -.025 mm)

TAPERED ROLLER BEARINGS

Units: INCHES
Millimeters



Cone Number	Bore	Cone Width	Max. shaft fillet radius	Cup Number	O.D.	Cup Width	Max. housing fillet radius	Overall Width
	d	B	R		D	b	r	T
4T-3500 SERIES								
4T-3578	1.7500 44.450	1.2160 30.886	.14 2.5	4T-3520	3.3125 84.138	.9375 23.812	.13 3.3	1.1875 30.162
4T-3578A	1.7500 44.450	1.2160 30.886	.22 5.5	4T-3525	3.4375 87.312	.9375 23.812	.13 3.3	1.1875 30.162
4T-3580	1.5000 38.100	1.2160 30.886	.06 1.0					
4T-3585	1.6250 41.275	1.2160 30.886	.06 1.0					
4T-3586	1.7810 45.237	1.2160 30.886	.14 2.5					
4T-3700 SERIES								
4T-3767	2.0625 52.388	1.1930 30.302	.09 2.3	4T-3720	3.6718 93.264	.9375 23.812	.13 3.3	1.1875 30.162
4T-3775	2.0000 50.800	1.1930 30.302	.03 .6	4T-3730	3.6718 93.264	.9375 23.812	.03 .8	1.1875 30.162
4T-3776	1.7710 44.983	1.1930 30.302	.14 2.5					
4T-3778	1.8750 47.625	1.1930 30.302	.25 6.4					
4T-3779	1.8750 47.625	1.1930 30.302	.14 2.5					
4T-3780	2.0000 50.800	1.1930 30.302	.14 2.5					
4T-3781	1.9375 49.212	1.1930 30.302	.14 2.5					
4T-3782	1.7500 44.450	1.1930 30.302	.14 2.5					
4T-3783	1.7500 44.450	1.1930 30.302	.25 6.4					
4T-3784	2.0000 50.800	1.1930 30.302	.25 6.4					
4T-3795	2.0000 50.800	1.1930 30.302	.14 2.5					
4T-3800 SERIES								
4T-3872	1.3750 34.925	1.1875 30.162	.14 2.5	4T-3820	3.3750 85.725	.9375 23.812	.13 3.3	1.1875 30.162
4T-3872A	1.3750 34.925	1.1875 30.162	.03 .6					
4T-3877	1.6250 41.275	1.1875 30.162	.14 2.5					
4T-3880	1.6250 41.275	1.1875 30.162	.03 .6					
4T-3900 SERIES								
4T-3979	2.2500 57.150	1.1830 30.048	.14 2.5	4T-3920	4.4375 112.712	.9375 23.812	.13 3.3	1.1875 30.162
4T-3982	2.5000 63.500	1.1830 30.048	.14 2.5	4T-3925	4.4375 112.712	.9375 23.812	.03 .8	1.1875 30.162
4T-3984	2.6250 66.675	1.1830 30.048	.14 2.5					
4T-3994	2.6250 66.675	1.1830 30.048	.22 5.5					
4T-4300 SERIES								
4T-4388	1.6250 41.275	1.5900 40.386	.14 2.5	4T-4335	3.5625 90.488	1.3125 33.338	.13 3.3	1.5625 39.688
4T-5300 SERIES								
4T-5356	1.7500 44.450	1.7510 44.475	.05 1.3	4T-5335	4.0625 103.188	1.4375 36.512	.13 3.3	1.7188 43.658
4T-5358	1.8750 47.625	1.7510 44.475	.05 1.3					
4T-5361	1.8750 47.625	1.7510 44.475	.14 2.5					
4T-5395	1.9375 49.212	1.7510 44.475	.14 2.5					

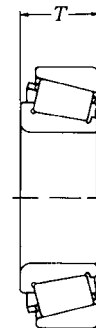
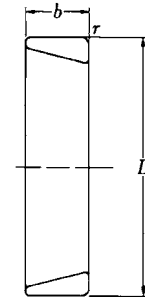
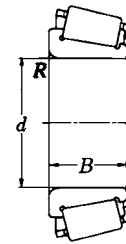

These maximum fillet radii will be cleared by the cone or cup radii.



Units: INCHES
Millimeters

TAPERED ROLLER BEARINGS

Cone Number	Bore	Cone Width	Max. shaft fillet radius	Cup Number	O.D.	Cup Width	Max. housing fillet radius	Overall Width
	<i>d</i>	<i>B</i>	<i>R</i>		<i>D</i>	<i>b</i>	<i>r</i>	<i>T</i>
4T-5500 SERIES								
4T-5562	1.9375 49.212	1.7230 43.764	.05 1.3	4T-5535	4.8125 122.238	1.4375 36.512	.13 3.3	1.7188 43.658
4T-5565	2.0000 50.800	1.7230 43.764	.05 1.3					
4T-5566	2.1875 55.562	1.7230 43.764	.05 1.3					
4T-5578	2.1250 53.975	1.7230 43.764	.14 2.5					
4T-5582	2.3750 60.325	1.7230 43.764	.03 .6					
4T-5583	2.3750 60.325	1.7230 43.764	.14 2.5					
4T-5584	2.5000 63.500	1.7230 43.764	.14 2.5					
4T-5595	2.5938 65.883	1.7230 43.764	.14 2.5					
4T-5700 SERIES								
4T-5760	3.0000 76.200	1.8150 46.100	.14 2.5	4T-5735	5.3438 135.733	1.3750 34.925	.13 3.3	1.7500 44.450
4T-5795	3.0625 77.788	1.8150 46.100	.14 2.5					
4T-6300 SERIES								
4T-6361	2.3622 60.000	2.2050 56.007	.12 2.5	4T-6320	5.3447 135.755	1.7500 44.450	.13 3.3	2.1250 53.975
4T-6376	2.3750 60.325	2.2050 56.007	.14 2.5					
4T-6379	2.5625 65.088	2.2050 56.007	.14 2.5					
4T-6381	*2.1649 55.000	2.2050 56.007	.14 2.5					
4T-6382	2.5000 63.500	2.2050 56.007	.17 4.3					
4T-6386	2.6250 66.675	2.2050 56.007	.17 4.3					
4T-6389	2.6250 66.675	2.2050 56.007	.25 6.4					
4T-6400 SERIES								
4T-6461A	3.0000 76.200	2.1350 54.229	.38 9.7	4T-6420	5.8750 147.225	1.7500 44.450	.13 3.3	2.1250 53.975
4T-6500 SERIES								
4T-6559	3.2500 82.550	2.1693 55.100	.14 2.5	4T-6535	6.3750 161.925	1.6875 42.862	.13 3.3	2.1250 53.975
4T-6576	3.0000 76.200	2.1693 55.100	.14 2.5					
4T-6580	3.5000 88.900	2.1693 55.100	.14 2.5					
4T-02400 SERIES								
4T-02474	1.1250 28.575	.8750 22.225	.03 .6	4T-02420	2.6875 68.262	.6875 17.462	.06 1.0	.8750 22.225
4T-02475	1.2500 31.750	.8750 22.225	.14 2.5					
4T-02800 SERIES								
4T-02872	1.1250 28.575	.8750 22.225	.03 .6	4T-02820	2.8750 73.025	.6875 17.462	.13 3.3	.8750 22.225
4T-05000 SERIES								
4T-05062	.6250 15.875	.5662 14.381	.06 1.0	4T-05185	1.8504 47.000	.4375 11.112	.05 1.3	.5662 14.381
4T-05079	*.7874 20.000	.5662 14.381	.06 1.0					
4T-07000 SERIES								
4T-07079	.7874 20.000	.5614 14.260	.06 1.0	4T-07196	1.9687 50.005	.3750 9.525	.04 .6	.5313 13.495
4T-07087	.8750 22.225	.5614 14.260	.05 1.3	4T-07204	2.0470 51.994	.5000 12.700	.05 1.3	.5910 15.011
4T-07093	.9375 23.812	.5614 14.260	.06 1.0	4T-07210X	2.0000 50.800	.5000 12.700	.06 1.0	.5910 15.011
4T-07100	1.0000 25.400	.5614 14.260	.04 .6					

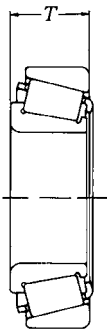
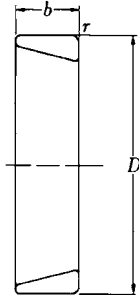
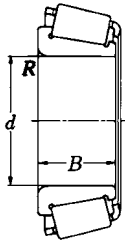

These maximum fillet radii will be cleared by the cone or cup radii.

* Tolerance +.0000 to -.0005 in. (+0 to -.013 mm)

TAPERED ROLLER BEARINGS

Units: INCHES
Millimeters



Cone Number	Bore	Cone Width	Max. shaft fillet radius	Cup Number	O.D.	Cup Width	Max. housing fillet radius	Overall Width
	<i>d</i>	<i>B</i>	<i>R</i>		<i>D</i>	<i>b</i>	<i>r</i>	<i>T</i>
4T-09000 SERIES								
4T-09067	.7500	.7500	.05	4T-09194	1.9380	.6875	.14	.8350
	19.050	19.050	1.3	0T-09195	1.9380	.5625	.05	.7100
				4T-09196	1.9380	.6875	.06	.8350
4T-09074	.7500	.8480	#	4T-09194	1.9380	.6875	.14	.9063
	19.050	21.539	#	4T-09195	1.9380	.5625	.05	.7813
4T-09078	.7500	.8480	.05	4T-09195	1.9380	.5625	.05	.7813
	19.050	21.539	1.3	4T-09196	1.9380	.6875	.06	.9063
					49.225	17.462	1.0	21.209
4T-11000 SERIES								
4T-11162	1.6250	.6844	.06	4T-11300	3.0000	.5625	.06	.7090
	41.275	17.384	1.0		76.200	14.288	1.0	18.009
4T-11500 SERIES								
4T-11590	.6250	.5625	.06	4T-11520	1.6875	.3750	.06	.5625
	15.875	14.288	1.0		42.862	9.525	1.0	14.288
4T-LM11700 SERIES								
* 4T-LM11749	.6875	.5750	.05	4T-LM11710	1.5700	.4200	.05	.5450
	17.462	14.605	1.3		39.878	10.668	1.3	13.843
4T-LM11900 SERIES								
* 4T-LM11949	.7500	.6550	.05	4T-LM11910	1.7810	.4750	.05	.6100
	19.050	16.637	1.3		45.237	12.065	1.3	15.494
4T-LM12000 SERIES								
4T-12175	1.7500	.6750	.06	4T-12303	3.0312	.4688	.06	.6875
	44.450	17.145	1.0		76.992	11.908	1.0	17.462
4T-LM12500 SERIES								
4T-12580	.8125	.7813	.06	4T-12520	1.9380	.6250	.06	.7813
	20.638	19.845	1.0		49.225	15.875	1.0	19.845
4T-LM12600 SERIES								
4T-M12649	.8437	.7200	.05	4T-M12610	1.9687	.5500	.05	.6900
	21.430	18.288	1.3		50.005	13.970	1.3	17.526
4T-LM112700 SERIES								
* 4T-LM12749	.8661	.6550	.05	4T-LM12710	1.7810	.4750	.05	.6100
	22.000	16.637	1.3		45.237	12.065	1.3	15.494
				4T-LM12711	1.8110	.4750	.05	.6100
					46.000	12.065	1.3	15.494
4T-13600 SERIES								
4T-13685	1.5000	.7500	.14	4T-13620	2.7170	.5938	.03	.7500
	38.100	19.050	2.5		69.012	15.083	.8	19.050
4T-13686	1.5000	1.0313	.06	4T-13621	2.7170	.5938	.09	.7500
	38.100	26.195	1.0		69.012	15.083	2.3	19.050
4T-13687	1.5000	.7500	.08					
	38.100	19.050	1.5					
4T-14000 SERIES								
4T-14116	1.1900	.7710	.03	4T-14274	2.7170	.6250	.13	.7813
	30.226	19.583	.6		69.012	15.875	3.3	19.845
4T-14117A	1.1811	.7710	.14	4T-14276	2.7170	.6250	.05	.7813
	30.000	19.583	2.5		69.012	15.875	1.3	19.845
4T-14118	1.1811	.7560	.03	4T-14282	2.8345	.5918	.06	.7481
	30.000	19.202	.6		71.996	15.032	1.0	19.002
4T-14124	1.2500	.7710	.03	4T-14283	2.8380	.7250	.09	.8813
	31.750	19.583	.6		72.085	18.415	2.3	22.385
4T-14125A	1.2500	.7710	.14					
	31.750	19.583	2.5					
4T-14131	1.3125	.7710	.03					
	33.338	19.583	.6					
4T-14137A	1.3750	.7710	.06					
	34.925	19.583	1.0					
4T-14138A	1.3750	.7710	.14					
	34.925	19.583	2.5					

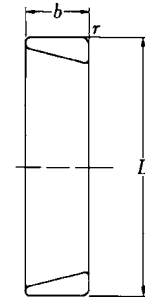
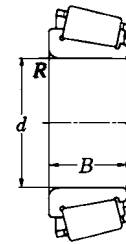

These maximum fillet radii will be cleared by the cone or cup radii. Tolerance +.0000 to -.0010 in. (-0 to -.025 mm)

* Cone Bore Tolerance .0008 to -.0000 in. (+0.020 to 0 mm) Tolerance +.0000 to -.0005 in. (+0 to -.013 mm)

Overall Bearing Width Tolerance +.0140 to -.0000 in. (+.356 to -0 mm) .08 in. (2.0 mm) x 45 degree front face chamfer

.06 in. (1.5 mm) x 45 degree chamfer



Units: INCHES
Millimeters

TAPERED ROLLER BEARINGS

Cone Number	Bore	Cone Width	Max. shaft fillet radius	Cup Number	O.D.	Cup Width	Max. housing fillet radius	Overall Width
	<i>d</i>	<i>B</i>	<i>R</i>		<i>D</i>	<i>b</i>	<i>r</i>	<i>T</i>
4T-14000 SERIES (Continued)								
# 4T-14136A	1.3750 34.925	1.0520 26.721	.03 .6	4T-14274	2.7170 69.012	.6250 15.875	.13 3.3	1.0623 26.982
				4T-14276	2.7170 69.012	.6250 15.875	.05 1.3	1.0623 26.982
				4T-14282	2.8345 71.996	.5918 15.032	.06 1.0	1.0291 26.139
				4T-14283	2.8380 71.996	.7250 18.418	.09 2.3	1.1623 29.500
4T-15000 SERIES								
4T-15100	1.0000 25.400	.8125 20.638	.14 2.5	4T-15243	2.4375 61.912	.5625 14.288	.08 1.5	.7500 19.050
4T-15101	1.0000 25.400	.8125 20.638	.14 2.5	4T-15244	2.4409 62.000	.6250 15.875	.05 1.3	.8125 20.638
4T-15103S	1.0300 26.162	.7850 19.939	.03 .6	4T-15245	2.4409 62.000	.5625 14.288	.05 1.3	.7500 19.050
4T-15106	1.0625 26.988	.8125 20.638	.03 .6	4T-15250	2.5000 63.500	.6250 15.875	.05 1.3	.8125 20.638
4T-15113	1.1250 28.575	.8125 20.638	.03 .6	4T-15250X	2.5000 63.500	.6250 15.875	.06 1.0	.8125 20.638
4T-15116	1.1855 30.112	.8125 20.638	.03 .6					
4T-15117	*1.1811 30.000	.8125 20.638	.05 1.3					
4T-15118	1.1895 30.213	.8125 20.638	.14 2.5					
4T-15119	1.1895 30.213	.8125 20.638	.06 1.0					
4T-15120	1.1895 30.213	.8125 20.638	.03 .6					
4T-15125	1.2500 31.750	.8125 20.638	.14 2.5					
4T-15126	1.2500 31.750	.8125 20.638	.03 .6					
4T-15123	1.2500 31.750	.7500 19.050		4T-15243	2.4375 61.912	.5625 14.288	.08 2.0	.7150 18.161
				4T-15244	2.4409 62.000	.6250 15.875	.05 1.3	.7775 19.749
				4T-15245	2.4409 62.000	.5625 14.288	.05 1.3	.7150 18.161
				4T-15250	2.5000 63.500	.6250 15.875	.05 1.3	.7775 19.749
				4T-15250X	2.5000 63.500	.6250 15.875	.06 1.5	.7775 19.749
4T-15500 SERIES								
4T-15578	1.0000 25.400	.6875 17.462	.05 1.3	4T-15520	2.2500 57.150	.5313 13.495	.06 1.5	.6875 17.462
4T-15580	1.0625 26.988	.6875 17.462	.14 2.5					
4T-15590	1.1250 28.575	.6875 17.462	.14 2.5					
4T-16000 SERIES								
4T-16150	1.5000 38.100	.8125 20.638	.14 2.5	4T-16282	2.8346 72.000	.5605 14.237	.06 1.5	.7480 19.000
				4T-16284	2.8440 72.238	.6250 15.875	.05 1.3	.8125 20.638
4T-17000 SERIES								
4T-17118	1.1811 30.000	.6522 16.566	.06 1.0	4T-17244	2.4409 62.000	.5625 14.288	.06 1.5	.6300 16.002
4T-17500 SERIES								
4T-17580	.6250 15.875	.6563 16.670	.06 1.0	4T-17520	1.6875 42.862	.5313 13.495	.06 1.5	.6563 16.670
4T-17800 SERIES								
4T-17887	1.7807 45.230	.8125 20.638	.08 1.5	4T-17831	3.1490 79.985	.5937 15.080	.05 1.3	.7812 19.842
4T-18500 SERIES								
4T-18590	1.6250 41.275	.6875 17.462	.14 2.5	4T-18520	2.8750 73.025	.5000 12.700	.06 1.5	.6562 16.667

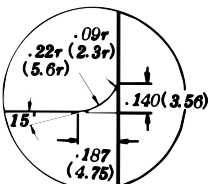
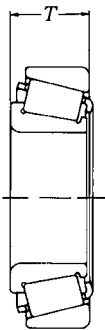
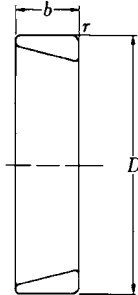
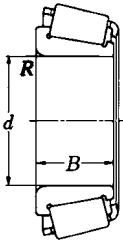

These maximum fillet radii will be cleared by the cone or cup radii.

* Tolerance .0000 to -.0005 in. (+0 to -.013 mm)

** Tolerance .0008 to .0000 in. (+.020 to 0 mm)

Extended shoulder on back face

TAPERED ROLLER BEARINGS

Units: INCHES
Millimeters



Cone Number	Bore	Cone Width	Max. shaft fillet radius	Cup Number	O.D.	Cup Width	Max. housing fillet radius	Overall Width
	<i>d</i>	<i>B</i>	<i>R</i>		<i>D</i>	<i>b</i>	<i>r</i>	<i>T</i>
4T-18600 SERIES								
4T-18685	1.7500 44.450	.6875 17.462	.11 2.8	4T-18620	3.1250 79.375	.5313 13.495	.06 1.0	.6875 17.462
4T-18690	1.8125 46.038	.6875 17.462	.11 2.8					
4T-18700 SERIES								
4T-18780	1.8125 46.038	.6875 17.462	.09 2.3	4T-18720	3.3465 85.000	.5313 13.495	.06 1.0	.6875 17.462
4T-18790	2.0000 50.800	.6875 17.462	.14 2.5					
4T-19000 SERIES								
4T-19150	1.5000 38.100	.6504 16.520	.06 1.0	4T-19268	2.6875 68.262	.4688 11.908	.06 1.0	.6250 15.875
				4T-19268X	2.6880 68.275	.6312 16.032	.06 1.0	.7874 20.000
				4T-19283X	2.8346 72.000	.5625 14.288	.08 1.5	.6700 17.018
4T-21000 SERIES								
4T-21075	.7500 19.050	.8598 21.839	.06 1.0	4T-21212	2.1250 53.975	.6250 15.875	.09 2.3	.8750 22.225
4T-22700 SERIES								
4T-22780	1.6875 42.862	1.0625 26.988	.14 2.5	4T-22720	3.2500 82.550	.8125 20.638	.13 3.3	1.0313 26.195
4T-23000 SERIES								
4T-23100	1.0000 25.400	.8450 21.463	.06 1.0	4T-23250X	2.5000 63.500	.5780 14.681	.09 2.3	.8540 21.692
4T-24700 SERIES								
4T-24780	1.6250 41.275	.9063 23.020	.14 2.5	4T-24720	3.0000 76.200	.6875 17.462	.03 .6	.8750 22.225
				4T-24721	3.0000 76.200	.8125 20.638	.09 2.3	1.0000 25.400
				4T-24722	3.0000 76.200	.6875 17.462	.13 3.3	.8750 22.225
4T-25500 SERIES								
4T-25577	1.6880 42.875	1.0000 25.400	.13 2.5	4T-25519	3.2500 82.550	.7500 19.050	.08 1.5	.9375 23.812
*4T-25578	1.6875 42.862	1.0000 25.400	.09 2.3	4T-25520	3.2650 82.931	.7500 19.050	.03 .6	.9375 23.812
4T-25580	1.7500 44.450	1.0000 25.400	.14 2.5	4T-25521	3.2700 83.058	.7500 19.050	.13 3.3	.9375 23.812
4T-25584	1.7710 44.983	1.0000 25.400	.06 1.0	4T-25522	3.2700 83.058	.7525 19.114	.08 1.5	.9400 23.876
4T-25590	1.7960 45.618	1.0000 25.400	.14 2.5	4T-25523	3.2650 82.931	.8750 22.225	.09 2.3	1.0625 26.988
				4T-25526	3.3465 85.000	.7500 19.050	.09 2.3	.9375 23.812
4T-25583	1.7500 44.450	1.4125 35.878		4T-25519	3.2500 82.550	.7500 19.050	.08 1.5	1.3500 34.290
				4T-25520	3.2650 82.931	.7500 19.050	.03 .6	1.3500 34.290
				4T-25521	3.2700 83.058	.7500 19.050	.13 3.3	1.3500 34.290
				4T-25522	3.2700 83.058	.7525 19.114	.08 1.5	1.3525 34.354
				4T-25523	3.2650 82.931	.8750 22.225	.09 2.3	1.4750 37.465
				4T-25526	3.3465 85.000	.7500 19.050	.09 2.3	1.3500 34.290
4T-25800 SERIES								
4T-25877	1.3750 34.925	.9688 24.608	.06 1.0	4T-25820	2.8750 73.025	.7500 19.050	.09 2.3	.9375 23.812
4T-25878	1.3750 34.925	.9688 24.608	.14 2.5	4T-25821	2.8750 73.025	.7500 19.050	.03 .6	.9375 23.812
4T-25880	1.4365 36.487	.9688 24.608	.06 1.0					

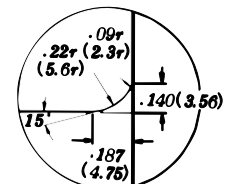
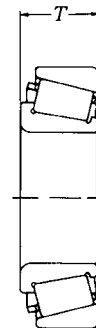
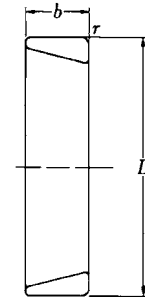
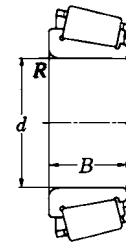

These maximum fillet radii will be cleared by the cone or cup radii.

* Large rib OD ground .03 in. (0.8 mm) x 45 front face chamfer.



Units: INCHES
Millimeters

TAPERED ROLLER BEARINGS

Cone Number	Bore	Cone Width	Max. shaft fillet radius	Cup Number	O.D.	Cup Width	Max. housing fillet radius	Overall Width
	<i>d</i>	<i>B</i>	<i>R</i>		<i>D</i>	<i>b</i>	<i>r</i>	<i>T</i>
4T-26800 SERIES								
4T-26878	1.5000 38.100	1.0000 25.400	.03 .6	4T-26820	3.1562 80.167	.8125 20.638	.13 3.3	1.0000 25.400
4T-26881	1.5625 39.688	1.0000 25.400	.14 2.5	4T-26822	3.1250 79.375	.7500 19.050	.03 .6	.9375 23.812
4T-26882	1.6250 41.275	1.0000 25.400	.14 2.5	4T-26823	3.0000 76.200	.8125 20.638	.06 1.0	1.0000 25.400
4T-26883	1.3780 35.000	1.0000 25.400	.03 .6	4T-26830	3.1562 80.167	.8125 20.638	.03 .6	1.0000 25.400
4T-26884	1.6880 42.875	1.0000 25.400	.14 2.5					
4T-26886	1.6880 42.875	1.0000 25.400	.06 1.0					
4T-27800 SERIES								
4T-27881	1.5000 38.100	.9330 23.698	.14 2.5	4T-27820	3.1510 80.035	.7288 18.512	.06 1.0	.9688 24.608
4T-28000 SERIES								
4T-28150	1.5000 38.100	.8244 20.940	.06 1.0	4T-28300	3.0000 76.200	.6105 15.507	.05 1.3	.8125 20.638
4T-28500 SERIES								
4T-28580	2.0000 50.800	1.0000 25.400	.14 2.5	4T-28520	3.5425 89.980	.7869 19.987	.09 2.3	.9744 24.750
4T-28584	2.0625 52.388	1.0000 25.400	.14 2.5	4T-28521	3.6250 92.075	.7813 19.845	.03 .6	.9688 24.608
4T-28600 SERIES								
4T-28678	2.0000 50.800	.9688 24.608	.14 2.5	4T-28621	3.8125 96.838	.7656 19.446	.03 .6	.9688 24.608
4T-28682	2.2500 57.150	.9688 24.608	.14 2.5	4T-28622	3.8437 97.630	.7656 19.446	.03 .6	.9688 24.608
4T-28900 SERIES								
4T-28980	2.3613 59.977	1.0000 25.400	.14 2.5	4T-28920	4.0000 101.600	.7813 19.845	.13 3.3	1.0000 25.400
4T-28985	2.3750 60.325	1.0000 25.400	.14 2.5	4T-28921	3.9370 100.000	.7813 19.845	.13 3.3	1.0000 25.400
4T-29500 SERIES								
4T-29585	2.5000 63.500	1.0000 25.400	.14 2.5	4T-29520	4.2500 107.950	.7500 19.050	.13 3.3	1.0000 25.400
4T-29600 SERIES								
4T-29675	2.7500 69.850	1.0000 25.400	.06 1.0	4T-29620	4.4375 112.712	.7500 19.050	.13 3.3	1.0000 25.400
4T-29685	2.8750 73.025	1.0000 25.400	.14 2.5	4T-29630	4.7500 120.650	.7500 19.050	.13 3.3	1.0000 25.400
4T-LM29700 SERIES								
4T-LM29748	1.5000 38.100	.7200 18.288		4T-LM29710	2.5625 65.088	.5500 13.970	.05 1.3	.7100 18.034
4T-31500 SERIES								
4T-31593	1.3750 34.925	1.1250 28.575	.14 2.5	4T-31520	3.0000 76.200	.9375 23.812	.13 3.3	1.1563 29.370
4T-31594	1.3750 34.925	1.1250 28.575	.06 1.0					
4T-31597	1.4375 36.512	1.1250 28.575	.14 2.5					
4T-33000 SERIES								
4T-33225	2.2500 57.150	1.1875 30.162	.14 2.5	4T-33462	4.6250 117.475	.9375 23.812	.13 3.3	1.1875 30.162
4T-33262	2.6250 66.675	1.1875 30.162	.14 2.5	4T-33472	4.7244 120.000	.9230 23.444	.03 .6	1.1730 29.764
4T-33275	2.7500 69.850	1.1875 30.162	.14 2.5					
4T-33281	2.8125 71.438	1.1875 30.162	.14 2.5					
4T-33287	2.8750 73.025	1.1875 30.162	.14 2.5					

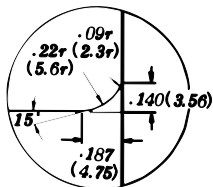
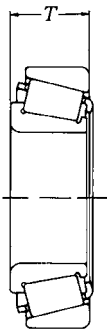
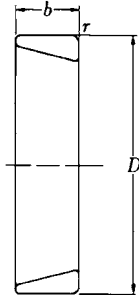
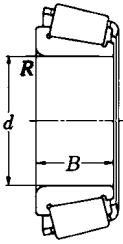

These maximum fillet radii will be cleared by the cone or cup radii.

TAPERED ROLLER BEARINGS

Units: INCHES
Millimeters



Cone Number	Bore d	Cone Width B	Max. shaft fillet radius R	Cup Number	O.D. D	Cup Width b	Max. housing fillet radius r	Overall Width T
4T-33800 SERIES								
4T-33891	2.0625 52.388	1.1250 28.575	.14 2.5	4T-33821	3.7500 95.250	.8750 22.225	.09 2.3	1.0938 27.783
4T-34000 SERIES								
4T-34306	3.0625 77.788	.9060 23.012	.14 2.5	4T-34478 4T-34492A	4.7812 121.442 4.9233 125.052	.6875 17.462 .6457 16.400	.08 1.5 .08 1.5	.9688 24.608 .9343 23.731
4T-39500 SERIES								
4T-39581	2.2500 57.150	1.1875 30.162	.31 6.0	4T-39520	4.4375 112.712	.9375 23.812	.13 3.3	1.1875 30.162
4T-39585	2.5000 63.500	1.1875 30.162	.14 2.5					
4T-39590	2.6250 66.675	1.1875 30.162	.14 2.5					
4T-41000 SERIES								
4T-41125	1.1250 28.575	.9550 24.257	.19 4.8	4T-41286	2.8593 72.626	.6875 17.462	.06 1.0	.9688 24.608
4T-42000 SERIES								
4T-42346	3.4630 87.960	1.1406 28.971	.12 2.5	4T-42584	5.8437 148.430	.8438 21.433	.12 2.5	1.1250 28.575
4T-42350	3.5000 88.900	1.1406 28.971	.12 2.5	4T-42587	5.8750 149.225	.9688 24.608	.13 3.3	1.2500 31.750
4T-42368	3.6875 93.662	1.1406 28.971	.12 2.5					
4T-42375	3.7500 95.250	1.1406 28.971	.12 2.5					
4T-42381	3.8125 96.838	1.1406 28.971	.14 2.5					
4T-42600 SERIES								
4T-42687	3.0000 76.200	1.2205 31.000	.14 2.5	4T-42620	5.0000 127.000	.8750 22.225	.13 3.3	1.1875 30.162
4T-43000 SERIES								
4T-43131	1.3125 33.338	.9478 24.074	.14 2.5	4T-43300	3.0000 76.200	.6563 16.670		.9688 24.608
4T-44000 SERIES								
4T-44150	1.5000 38.100	.9330 23.698	.09 2.3	4T-44348	3.4834 88.500	.6875 17.462	.06 1.0	1.0000 25.400
4T-L44600 SERIES								
*4T-L44640	.9375 23.813	.5800 14.732	.06 1.0	4T-L44610	1.9800 50.292	.4200 10.668	.05 1.3	.5600 14.224
*4T-L44643	1.0000 25.400	.5800 14.732	.05 1.3					
*4T-L44649	1.0625 26.988	.5800 14.732	.14 2.5					
4T-45200 SERIES								
4T-45282	1.8750 47.625	1.2188 30.958	.14 2.5	4T-45220	4.1250 104.775	.9375 23.813	.13 3.3	1.1875 30.162
4T-45284	2.0000 50.800	1.2188 30.958	.25 6.4					
4T-L45400 SERIES								
*4T-L45449	1.1417 29.000	.5800 14.732	.14 2.5	4T-L45410	1.9800 50.292	.4200 10.668	.05 1.3	.5600 14.224
4T-46000 SERIES								
4T-46143	1.4375 36.512	1.2500 31.750	.06 1.0	4T-46368	3.6875 93.662	1.0313 26.195	.13 3.3	1.2500 31.750
4T-46162	1.6250 41.275	1.2500 31.750	.03 .6	4T-46369	3.6875 93.662	1.0313 26.195	.05 1.3	1.2500 31.750
4T-46700 SERIES								
4T-46790	6.5000 165.100	1.5625 39.688	.14 2.5	4T-46720	8.8750 225.425	1.3125 33.338	.13 3.3	1.6250 41.275

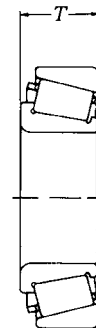
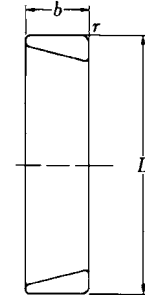
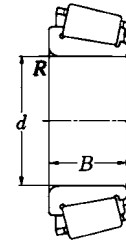

These maximum fillet radii will be cleared by the cone or cup radii.

- * Cone bore tolerance +.0008 to -.0000 in. (+.020 to -0 mm)
- Overall bearing width tolerance +.0140 to -.0000 in. (+.356 to -0 mm)
- .13 in. (3.3 mm) x 45 degree back face chamfer



Units: INCHES
Millimeters

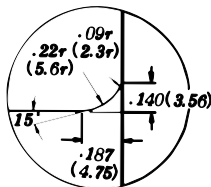
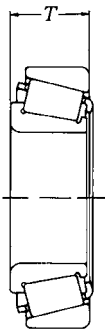
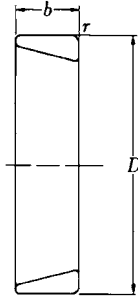
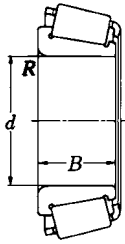

TAPERED ROLLER BEARINGS

Cone Number	Bore	Cone Width	Max. shaft fillet radius	Cup Number	O.D.	Cup Width	Max. housing fillet radius	Overall Width
	<i>d</i>	<i>B</i>	<i>R</i>		<i>D</i>	<i>b</i>	<i>r</i>	<i>T</i>
4T-47600 SERIES								
4T-47678	3.0000 76.200	1.3125 33.338	.25 6.4	4T-47620	5.2500 133.350	1.0313 26.195	.13 3.3	1.3125 33.338
4T-47679	3.0000 76.200	1.3125 33.338	.14 2.5	4T-47623A	5.3750 136.525	1.7500 44.450		1.7500 44.450
4T-47681	3.1875 80.962	1.3125 33.338	.14 2.5					
4T-47686	3.2500 82.550	1.3125 33.338	.14 2.5					
4T-47687	3.2500 82.550	1.3125 33.338	.27 6.8					
4T-47800 SERIES								
4T-47890	3.6250 92.075	1.3750 34.925	.14 2.5	4T-47820	5.7500 146.050	1.0313 26.195	.13 3.3	1.3125 33.338
4T-47896	3.7500 95.250	1.3750 34.925	.14 2.5					
4T-LM48500 SERIES								
#4T-LM48548	1.3750 34.925	.7200 18.288		4T-LM48510	2.5625 65.088	.5500 13.970	.05 1.3	.7100 18.034
4T-48600 SERIES								
4T-48684	5.6250 142.875	1.5625 39.688	.31 .6	4T-48620	7.8750 200.025	1.3437 34.130	.13 3.3	1.6250 41.275
4T-49000 SERIES								
4T-49175	1.7500 44.450	1.2500 31.750	.14 2.5	4T-49368	3.6875 93.662	1.0000 25.400	.13 3.3	1.2500 31.750
4T-49500 SERIES								
4T-49585	2.0000 50.800	1.2500 31.750	.14 2.5	4T-49520	4.0000 101.600	1.0000 25.400	.13 3.3	1.2500 31.750
4T-52000 SERIES								
4T-52387	3.8750 98.425	1.4219 36.116	.14 2.5	4T-52618	6.1875 157.162	1.0313 26.195	.13 3.3	1.4375 36.512
4T-52400	4.0000 101.600	1.4219 36.116	.14 2.5	4T-52638	6.3750 161.925	1.1563 29.370	.13 3.3	1.5625 39.688
4T-52401	4.0000 101.600	1.4219 36.116	.31 .6					
4T-55000C SERIES								
4T-55175C	1.7500 44.450	1.0594 26.909	.14 2.5	4T-55437	4.3750 111.125	.8125 20.638	.13 3.3	1.1875 30.162
4T-55200C	2.0000 50.800	1.0594 26.909	.14 2.5					
4T-56000 SERIES								
4T-56425	4.2500 107.950	1.4375 36.512	.14 2.5	4T-56650	6.5000 165.100	1.0625 26.988	.13 3.3	1.4375 36.512
4T-59000 SERIES								
4T-59162	1.6250 41.275	1.4375 36.512	.06 1.0	4T-59429	4.2900 108.966	1.0625 26.987	.13 3.3	1.3750 34.925
4T-59200	2.0000 50.800	1.4375 36.512	.14 2.5					
4T-65300 SERIES								
4T-65390	1.9375 49.212	1.7500 44.450	.14 2.5	4T-65320	4.5000 114.300	1.3750 34.925	.13 3.3	1.7500 44.450
4T-LM67000 SERIES								
#4T-LM67048	1.2500 31.750	.6600 16.764		4T-LM67010	2.3280 59.131	.4650 11.811	.05 1.3	.6250 15.875
4T-67300 SERIES								
4T-67388	5.0000 127.000	1.8125 46.038	.14 2.5	4T-67322	7.7500 196.850	1.5000 38.100	.13 3.3	1.8125 46.038
				4T-67324	8.0000 203.200	1.8125 46.038	.13 3.3	1.8125 46.038

These maximum fillet radii will be cleared by the cone or cup radii.

Cone bore tolerance +.0008 to -.0000 in. (+.020 to -.0 mm)

Overall bearing width tolerance +.0140 to -.0000 in. (+.356 to -.0 mm)

Threaded O.D.

Front face corner break .015 in. (0.38 mm) max.

.03 in. (.8 mm) x 45 degree back face chamfer

TAPERED ROLLER BEARINGS

Units: INCHES
Millimeters



Cone Number	Bore	Cone Width	Max. shaft fillet radius	Cup Number	O.D.	Cup Width	Max. housing fillet radius	Overall Width
	<i>d</i>	<i>B</i>	<i>R</i>		<i>D</i>	<i>b</i>	<i>r</i>	<i>T</i>
4T-L68100 SERIES								
4T-L68149	*1.3780 35.000	.6600 16.764		4T-L68110	2.3280 59.131	.4700 11.938	.05 1.3	.6250 15.875
				4T-L68111	2.3622 60.000	.4700 11.938	.05 1.3	.6250 15.875
4T-L69300 SERIES								
4T-JL69349	1.4961 38.000	.6693 17.000		4T-JL69310	2.4803 63.000	.5313 13.495	.05 1.3	.6693 17.000
4T-72000C SERIES								
4T-72188C	1.8750 47.625	1.2910 32.791	.03 .6	4T-72487	4.8750 123.825	1.0000 25.400	.13 3.3	1.4375 36.512
4T-72200C	2.0000 50.800	1.2910 32.791	.14 2.5					
4T-78000C SERIES								
4T-78215C	2.1250 53.975	1.3085 33.236	.14 2.5	4T-78551	5.5130 140.030	.9260 23.520	.09 2.3	1.4375 36.512
4T-78225C	2.2500 57.150	1.3085 33.236	.14 2.5					
4T-78238C	2.3750 60.325	1.3085 33.236	.20 4.0					
4T-LM78300 SERIES								
4T-LM78349	*1.3780 35.000	.6693 17.000		4T-LM78310A	2.4409 62.000	.5354 13.600	.06 1.0	.6575 16.700
4T-HM81600 SERIES								
4T-HM81649	*.6299 16.000	.8268 21.000	.04 .6	4T-HM81610	1.8504 47.000	.6299 16.000	.08 1.5	.8268 21.000
4T-M84200 SERIES								
4T-M84249	1.0000 25.400	.9100 23.114	.03 .6	4T-M84210	2.3437 59.530	.7200 18.288	.06 1.0	.9200 23.368
4T-M84500 SERIES								
4T-M84548	1.0000 25.400	.7650 19.431	.06 1.0	4T-M84510	2.2500 57.150	.5800 14.732	.06 1.0	.7650 19.431
4T-M86600 SERIES								
4T-M86649	1.1875 30.162	.8438 21.433	.06 1.0	4T-M86610	2.5312 64.292	.6563 16.670	.06 1.0	.8438 21.433
4T-M88800 SERIES								
4T-M88048	1.3125 33.338	.8750 22.225	.03 .6	4T-M88010	2.6875 68.262	.6875 17.462	.06 1.0	.8750 22.225
4T-HM88500 SERIES								
4T-HM88542	1.2500 31.750	1.0928 27.783	.05 1.3	4T-HM88510	2.8750 73.025	.9063 23.020	.13 3.3	1.1563 29.370
4T-HM88547	1.3125 33.338	1.0938 27.783	.03 .6					
4T-HM88600 SERIES								
4T-HM88649	1.3750 34.925	1.0000 25.400	.09 2.3	4T-HM88610	2.8438 72.233	.7812 19.842	.09 2.3	1.0000 25.400
				4T-HM88611	2.8346 72.000	.8442 21.443	.06 1.0	1.0630 27.000
4T-HM89400 SERIES								
4T-HM89443	1.3125 33.338	1.1250 28.575	.03 .6	4T-HM89410	3.0000 76.200	.9063 23.020	.13 3.3	1.1563 29.370
4T-HM89446	1.3750 34.925	1.1250 28.575	.14 2.5	4T-HM89411	3.0000 76.200	.9063 23.020	.03 .6	1.1563 29.370
4T-HM89448	1.4375 36.512	1.1250 28.575	.03 .6					
4T-HM89449	1.4375 36.512	1.1250 28.575	.14 2.5					
4T-LM102900 SERIES								
4T-LM102949	1.7812 45.242	.7800 19.812	.14 2.5	4T-LM102910	2.8910 73.431	.6200 15.748	.03 .6	.7700 19.558

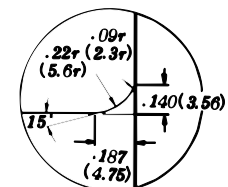
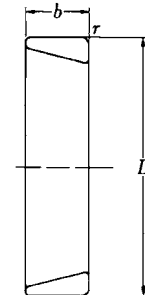
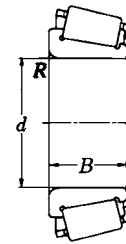

These maximum fillet radii will be cleared by the cone or cup radii. .06 in. (1.5 mm) front face chamfer
 Cup outside dia. tolerance +.0000 to -.0010 in. (+0 to -.025 mm) * Tolerance +.0000 to -.0005 in. (+0 to -.013 mm)
 Overall bearing width tolerance +.0140 to -.0000 in. (+0.356 to -.0 mm)
 For 'J' prefix part tolerances see Table 8 Pg. 254



Units: INCHES
Millimeters

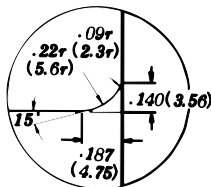
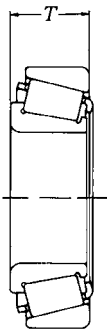
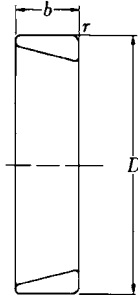
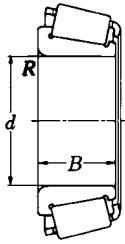

TAPERED ROLLER BEARINGS

Cone Number	Bore	Cone Width	Max. shaft fillet radius	Cup Number	O.D.	Cup Width	Max. housing fillet radius	Overall Width
	<i>d</i>	<i>B</i>	<i>R</i>		<i>D</i>	<i>b</i>	<i>r</i>	<i>T</i>
4T-LM104900 SERIES								
4T-LM104949	2.0000 50.800	.8750 22.225	.14 2.5	4T-LM104911	3.2500 82.550	.6500 16.510	.05 1.3	.8500 21.590
4T-JLM104948	1.9685 50.000	.8465 21.500	.12 2.5	4T-JLM104910	3.2283 82.000	.6693 17.000	.02 .3	.8465 21.500
4T-M201000 SERIES								
4T-M201047	1.5625 39.688	.8700 22.098	.03 .6	4T-M201011	2.8750 73.025	.8400 21.336	.09 2.3	1.0100 25.654
4T-M205100 SERIES								
4T-JM205149	1.9685 50.000	1.1024 28.000	.12 2.5	4T-JM205110	3.5433 90.000	.9055 23.000	.10 2.0	1.1024 28.000
4T-M207000 SERIES								
4T-JM207049	2.1654 55.000	1.1417 29.000	.06 1.0	4T-JM207010	3.7402 95.000	.9252 23.500	.10 2.0	1.1417 29.000
4T-H211700 SERIES								
4T-JH211749	2.5591 65.000	1.5157 38.500	.12 2.5	4T-JH211710	4.7244 120.000	1.2598 32.000	.10 2.0	1.5354 39.000
4T-HM212000 SERIES								
4T-HM212044	2.3750 60.325	1.5100 38.354	.31 6.0	4T-HM212010	4.8125 122.238	1.1700 29.718	.06 1.0	1.5000 38.100
4T-HM212046	2.5000 63.500	1.5100 38.354	.14 2.5	4T-HM212011	4.8125 122.238	1.1700 29.718	.13 3.3	1.5000 38.100
4T-HM212047	2.5000 63.500	1.5100 38.354	.28 7.0					
4T-HM212049	2.6250 66.675	1.5100 38.354	.14 2.5					
4T-H212700 SERIES								
4T-H212749	*2.5984 66.000	1.6339 41.500	.28 7.0	4T-212710	4.8819 124.000	1.3386 34.000	.14 2.5	1.6339 41.500
4T-L217800 SERIES								
4T-L217849	3.5000 88.900	.8125 20.638	.06 1.0	4T-L217810	4.8750 123.825	.6563 16.670	.06 1.0	.8125 20.638
4T-HM218200 SERIES								
4T-HM218248	3.5433 90.000	1.5748 40.000	.28 7.0	4T-HM218210	5.7874 147.000	1.2795 32.500	.14 2.5	1.5748 40.000
4T-HM220100 SERIES								
4T-HM220149	*3.9370 100.000	1.6535 42.000	.31 6.0	4T-HM220110	6.1811 157.000	1.3386 34.000	.14 2.5	1.6535 42.000
4T-LM300800 SERIES								
4T-LM300849	*1.6142 41.000	.7087 18.000		4T-LM300811	2.6772 68.000	.5315 13.500	.06 1.0	.6890 17.500
4T-H307700 SERIES								
4T-JH307749	2.1654 55.000	1.5354 39.000	.12 2.5	4T-JH307710	4.3307 110.000	1.2598 32.000	.10 2.0	1.5354 39.000
4T-LM501300 SERIES								
4T-LM501349	1.6250 41.275	.7800 19.812	.14 2.5	4T-LM501310	2.8910 73.431	.5800 14.732	.03 .6	.7700 19.558
				4T-LM501314	2.8910 73.431	.6537 16.604	.03 .6	.8437 21.430
4T-LM503300 SERIES								
4T-LM503349	*1.8110 46.000	.7087 18.000	.09 2.3	4T-LM503310	2.9528 75.000	.5512 14.000	.06 1.0	.7087 18.000
4T-HH506300 SERIES								
4T-HH506348	1.9375 49.212	1.7500 44.450	.14 2.5	4T-HH506310	4.5000 114.300	1.4200 36.068	.13 3.3	1.7500 44.450
4T-LM506800 SERIES								
4T-JLM506849	2.1654 55.000	.9055 23.000	.06 1.0	4T-JLM506810	3.5433 90.000	.7283 18.500	.02 .3	.9055 23.000

These maximum fillet radii will be cleared by the cone or cup radii.

- * Cone bore tolerance +.0000 to -.0005 in. (+0 to -.013 mm)
- Cup outside dia. tolerance +.0000 to -.0010 in. (+0 to -.025 mm)
- .09 in. (2.3 mm) front face chamfer
- Tolerance +.0000 to -.0010 in. (+0 to -.025 mm)
- For 'J' prefix part tolerances see Table 8 Page 254

TAPERED ROLLER BEARINGS

Units: INCHES
Millimeters



Cone Number	Bore	Cone Width	Max. shaft fillet radius	Cup Number	O.D.	Cup Width	Max. housing fillet radius	Overall Width
	<i>d</i>	<i>B</i>	<i>R</i>		<i>D</i>	<i>b</i>	<i>r</i>	<i>T</i>
4T-LM508700 SERIES								
4T-JLM508748	2.3622 60.000	.9449 24.000	.20 5.0	4T-JLM508710	3.7402 95.000	.7480 19.000	.10 2.5	.9449 24.000
4T-M511900 SERIES								
4T-JM511946	2.5590 65.000	1.1024 28.000	.12 3.0	4T-JM511910	4.3307 110.000	.8858 22.500	.10 2.5	1.1024 28.000
4T-HM516400 SERIES								
4T-HM516448	3.2500 82.550	1.5625 39.688	.27 6.8	4T-HM516410	5.2500 133.350	1.2813 32.545	.13 3.3	1.5625 39.688
4T-M515600 SERIES								
4T-JM515649	3.1496 80.000	1.3386 34.000	.12 3.0	4T-JM515610	5.1181 130.000	1.1220 28.500	.10 2.5	1.3780 35.000
4T-HM515700 SERIES								
4T-HM515745	3.0000 76.200	1.8150 46.100	.14 3.5	4T-HM515716	5.5960 142.138	1.3125 33.338	.13 3.3	1.7500 44.450
4T-HM516800 SERIES								
4T-JHM516849	3.3465 85.000	1.4961 38.000	.12 3.0	4T-JHM516810	5.5118 140.000	1.2402 31.500	.10 2.5	1.5354 39.000
4T-HM518400 SERIES								
4T-HM518445	3.5000 88.900	1.5625 39.688	.25 6.4	4T-HM518410	6.0000 152.400	1.1875 30.163	.13 3.3	1.5625 39.688
4T-HM522600 SERIES								
4T-JHM522649	4.3307 110.000	1.8110 46.000	.12 3.0	4T-JHM522610	7.0866 180.000	1.4961 38.000	.10 2.5	1.8504 47.000
4T-LM603000 SERIES								
4T-LM603049	1.7812 45.242	.7812 19.842	.14 3.5	4T-LM603011	3.0625 77.788	.5937 15.080	.03 .8	.7812 19.842
				4T-LM603012	3.0625 77.788	.6562 16.667	.03 .8	.8437 21.430
4T-LM612900 SERIES								
4T-JM612949	2.7559 70.000	1.1417 29.000	.12 3.0	4T-JM612910	4.5276 115.000	.9055 23.000	.10 2.5	1.1417 29.000
4T-HM617000 SERIES								
4T-HM617049	3.3750 85.725	1.6875 42.862	.19 4.8	4T-HM617010	5.5960 142.138	1.3438 34.133	.13 3.3	1.6875 42.862
4T-M704600 SERIES								
4T-JLM704649	1.9685 50.000	.8661 22.000	.14 3.5	4T-JLM704610	3.3071 84.000	.6890 17.500	.06 1.5	.8661 22.000
4T-LM710900 SERIES								
4T-JLM710949	2.5591 65.000	.9055 23.000	.12 3.0	4T-JLM710910	4.1339 105.000	.7283 18.500	.04 1.0	.9449 24.000
4T-M714200 SERIES								
4T-JM714249	2.9528 75.000	1.1614 29.500	.12 3.0	4T-JM714210	4.7244 120.000	.9843 25.000	.10 2.5	1.2205 31.000
4T-H715300 SERIES								
4T-H715343	2.6875 68.262	1.8125 46.038	.14 3.5	4T-H715311	5.3750 136.525	1.4375 36.512	.13 3.3	1.8125 46.038
4T-H715345	2.8125 71.438	1.8125 46.038	.14 3.5	4T-H715313W	5.3750 136.525	1.5625 39.688	.13 3.3	1.9375 49.213
4T-M716600 SERIES								
4T-JM716649	3.3465 85.000	1.1417 29.000	.12 3.0	4T-JM716610	5.1181 130.000	.9449 24.000	.10 2.5	1.1811 30.000
4T-M718100 SERIES								
4T-JM718149	3.5433 90.000	1.3386 34.000	.12 3.0	4T-JM718110	5.7087 145.000	1.0630 27.000	.10 2.5	1.3780 35.000

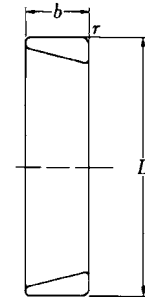
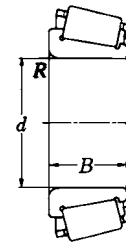

These maximum fillet radii will be cleared by the cone or cup radii.

* For 'J' prefix part tolerances see Table 8 Page 254

Key way on backface



Units: INCHES
Millimeters

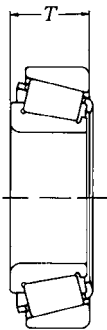
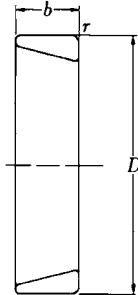
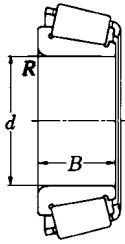

TAPERED ROLLER BEARINGS

Cone Number	Bore	Cone Width	Max. shaft fillet radius	Cup Number	O.D.	Cup Width	Max. housing fillet radius	Overall Width
	<i>d</i>	<i>B</i>	<i>R</i>		<i>D</i>	<i>b</i>	<i>r</i>	<i>T</i>
4T-M719100 SERIES								
4T-JM719149	3.7402 95.000	1.3386 34.000	.12 3.0	4T-JM719113	5.9055 150.000	1.0630 27.000	.10 2.5	1.3780 35.000
4T-HM720200 SERIES								
4T-JHM720249	3.9370 100.000	1.5748 40.000	.12 3.0	4T-JHM720210	6.2992 160.000	1.2598 32.000	.10 2.5	1.6142 41.000
4T-M736100 SERIES								
4T-JM736149	7.0866 180.000	1.7717 45.000	.12 3.0	4T-JM736110	9.8425 250.000	1.4567 37.000	.10 2.5	1.8504 47.000
4T-LM739700 SERIES								
4T-LM739749	7.7500 196.850	1.5625 39.688	.14 3.5	4T-LM739710	10.1250 257.175	1.1875 30.162	.13 3.3	1.5625 39.688
4T-HM801300 SERIES								
4T-HM801346	1.5000 38.100	1.1250 28.575	.03 .8	4T-HM801310	3.2500 82.550	.9063 23.020	.13 3.3	1.1563 29.370
4T-M802000 SERIES								
4T-M802048	1.6250 41.275	1.0100 25.654	.14 3.5	4T-M802011	3.2500 82.550	.7950 20.193	.13 3.3	1.0450 26.543
4T-HM803100 SERIES								
4T-HM803146	1.6250 41.275	1.1563 29.370	.14 3.5	4T-HM803110	3.5000 88.900	.9063 23.020	.13 3.3	1.1875 30.162
4T-HM803149	1.7500 44.450	1.1563 29.370	.14 3.5					
4T-M804000 SERIES								
4T-M804049	1.8750 47.625	1.0000 25.400	.14 3.5	4T-M804010	3.5000 88.900	.7500 19.050	.13 3.3	1.0000 25.400
4T-M804800 SERIES								
4T-HM804846	1.8750 47.625	1.1563 29.370	.14 3.5	4T-HM804810	3.7500 95.250	.9063 23.020	.13 3.3	1.1875 30.162
4T-HM804848	1.9060 48.412	1.1563 29.370	.09 2.3					
4T-LM806600 SERIES								
4T-LM806649	2.1250 53.975	.7500 19.050	.09 2.3	4T-LM806610	3.5000 88.900	.5312 13.492	.08 2.0	.7500 19.050
4T-HM807000 SERIES								
4T-HM807040	1.7500 44.450	1.4375 36.512	.14 3.5	4T-HM807010	4.1250 104.775	1.1250 28.575	.13 3.3	1.4375 36.512
4T-HM807044	1.9375 49.212	1.4375 36.512	.14 3.5					
4T-HM807046	2.0000 50.800	1.4375 36.512	.14 3.5					
4T-HM807049	2.1250 53.975	1.4375 36.512	.14 3.5					
4T-LM813000 SERIES								
4T-JLM813049	2.7559 70.000	.9843 25.000	.04 1.0	4T-JLM813010	4.3307 110.000	.8071 20.500	.10 2.5	1.0236 26.000
4T-HM813800 SERIES								
4T-HM813840	2.1875 55.562	1.4375 36.512	.14 3.5	4T-HM813810	5.0000 127.000	1.0625 26.988	.13 3.3	1.4375 36.512
4T-HM813841	2.3750 60.325	1.4375 36.512	.14 3.5					
4T-M822000 SERIES								
4T-JM822049	4.3307 110.000	1.3780 35.000	.12 3.0	4T-JM822010	6.4961 165.000	1.0433 26.500	.10 2.5	1.3780 35.000
4T-HM903200 SERIES								
4T-HM903249	1.7500 44.450	1.1250 28.575	.14 3.5	4T-HM903210	3.7500 95.250	.8750 22.225	.03 .8	1.2188 30.958
4T-HM903249A	1.7500 44.450	1.1142 28.300	.14 3.5					

These maximum fillet radii will be cleared by the cone or cup radii.

* For 'J' prefix part tolerances see Table 8 Page 254



**RATING AT 33.3 RPM FOR 500 HOURS
BASED ON AFBMA**

TAPERED ROLLER BEARINGS

TAPERED ROLLER BEARINGS											
Series	Basic Load Ratings (lbs)		Series	Basic Load Ratings (lbs)		Series	Basic Load Ratings (lbs)		Series	Basic Load Ratings (lbs)	
	Dynamic C	Static C ₀		Dynamic C	Static C ₀		Dynamic C	Static C ₀		Dynamic C	Static C ₀
4T-335	15,300	16,900	4T-6500	69,000	104,000	4T-39500	31,000	43,500	4T-L217800	18,000	31,500
4T-355	15,700	17,800	4T-02400	12,800	15,100	4T-41000	13,100	12,500	4T-HM218200	51,000	76,500
4T-365	17,200	20,400	4T-02800	12,700	15,300	4T-42000	31,000	48,500	4T-HM220100	56,000	85,500
4T-385	17,600	21,700	4T-05000	5,400	5,450	4T-42600	30,500	43,500	4T-LM300800	10,300	14,100
4T-395	20,100	27,000	4T-07000	5,850	6,300	4T-43000	14,700	15,000	4T-H307700	39,000	49,500
4T-415	21,500	24,100	4T-09000	8,600	8,700	4T-44000	15,900	17,500	4T-LM501300	12,600	15,700
4T-435	24,300	29,100	4T-11000	9,550	11,600	4T-L44600	6,500	7,600	4T-LM503300	11,500	16,000
4T-455	25,800	33,000	4T-11500	3,950	3,950	4T-45200	29,200	38,000	4T-HH506300	45,500	58,500
4T-475	28,700	40,000	4T-LM11700	5,350	5,450	4T-L45400	6,300	8,000	4T-LM506800	17,400	24,400
4T-495	29,000	42,500	4T-LM11900	6,350	6,450	4T-46000	23,300	29,500	4T-LM508700	18,700	27,300
4T-525	30,500	37,000	4T-12000	9,850	12,200	4T-46700	57,000	125,000	4T-M511900	26,800	39,000
4T-535	32,000	40,000	4T-12500	8,400	8,750	4T-47600	34,500	53,000	4T-M515600	37,500	56,000
4T-555	35,500	48,500	4T-M12600	8,500	8,750	4T-47800	37,000	59,500	4T-HM515700	45,000	62,500
4T-565	36,500	51,500	4T-LM12700	6,650	7,600	4T-LM48500	10,400	12,600	4T-HM516400	40,000	68,000
4T-575	40,000	59,500	4T-13600	10,700	13,400	4T-48600	53,500	110,000	4T-HM516800	44,500	67,000
4T-595	40,500	62,500	4T-14000	10,800	13,000	4T-49000	25,000	30,000	4T-HM518400	57,000	81,500
4T-615	38,500	48,000	4T-15000	10,500	12,200	4T-49500	24,800	30,500	4T-HM522600	68,500	108,000
4T-635	43,500	59,000	4T-15500	8,900	10,200	4T-52000	42,000	68,000	4T-LM603000	12,900	16,600
4T-655	46,500	66,500	4T-16000	10,800	13,100	4T-55000C	23,400	30,500	4T-M612900	28,000	38,500
4T-675	50,000	77,000	4T-17000	8,750	9,500	4T-56000	43,000	70,500	4T-HM617000	48,500	78,500
4T-745	58,500	81,000	4T-17500	6,000	5,850	4T-59000	32,000	40,000	4T-LM704600	15,700	21,200
4T-755	60,500	86,500	4T-17800	13,400	17,000	4T-65300	42,000	50,500	4T-LM710900	19,200	26,200
4T-795	70,500	116,000	4T-18500	10,300	12,500	4T-LM67000	7,750	9,200	4T-M714200	29,400	44,500
4T-855	85,500	124,000	4T-18600	10,200	12,600	4T-67300	69,500	124,000	4T-H715300	50,500	80,000
4T-935	107,000	156,000	4T-18700	11,100	14,600	4T-L68100	7,950	10,700	4T-M716600	30,500	48,000
4T-1300	9,150	9,600	4T-19000	9,750	11,500	4T-L69300	8,700	11,800	4T-M718100	42,500	62,500
4T-1700	9,600	10,400	4T-21000	9,050	8,700	4T-72000C	34,500	42,500	4T-M719100	40,500	62,500
4T-1900	9,150	10,000	4T-22700	16,900	21,800	4T-78000C	38,500	47,500	4T-HM720200	43,000	69,500
4T-2500	15,500	18,300	4T-23000	10,600	11,400	4T-LM78300	8,350	10,800	4T-M736100	83,000	160,000
4T-2600	14,400	16,300	4T-24700	14,600	18,100	4T-HM81600	7,850	8,150	4T-LM739700	60,500	142,000
4T-2700	16,400	20,300	4T-25500	17,100	22,000	4T-M84200	11,200	13,000	4T-HM801300	19,500	26,300
4T-2900	17,700	23,400	4T-25800	15,900	19,200	4T-M84500	9,500	11,000	4T-M802000	18,100	23,400
4T-3100	19,000	22,000	4T-26800	17,200	21,900	4T-M86600	11,600	14,600	4T-803100	21,000	28,000
4T-3300	21,400	25,100	4T-27800	15,100	18,500	4T-M88000	12,700	16,000	4T-M804000	18,500	22,800
4T-3400	20,900	25,600	4T-28000	12,500	14,200	4T-HM88500	16,200	21,800	4T-HM804800	24,400	33,000
4T-3500	21,200	26,400	4T-28500	18,800	26,100	4T-HM88600	14,600	19,000	4T-LM806600	13,700	18,600
4T-3700	22,900	30,000	4T-28600	19,900	28,700	4T-HM89400	17,500	23,700	4T-HM807000	31,000	42,500
4T-3800	23,600	29,600	4T-28900	20,300	30,000	4T-LM102900	12,200	17,100	4T-LM813000	21,800	33,500
4T-3900	26,800	39,000	4T-29500	20,600	31,500	4T-LM104900	15,700	21,100	4T-HM813800	36,500	51,500
4T-4300	30,500	39,500	4T-29600	21,500	34,000	4T-M201000	14,000	17,800	4T-M822000	43,000	70,500
4T-5300	39,000	52,000	4T-LM29700	9,750	12,800	4T-M205100	23,900	31,500	4T-HM903200	21,600	26,100
4T-5500	43,500	63,500	4T-31500	18,100	21,800	4T-M207000	24,000	32,500			
4T-5700	47,500	74,500	4T-33000	26,200	39,500	4T-H211700	41,500	55,500			
4T-6300	62,500	85,000	4T-33800	24,100	31,000	4T-HM212000	42,000	55,000			
4T-6400	64,500	92,000	4T-34000	20,500	28,600	4T-H212700	46,000	62,500			



Bearing Series

→ 4T-335 SERIES

4T-335 / 332.....

1.18 ←

Cone Number

Cup Number

Weight (lbs)

TAPERED ROLLER BEARINGS

LBS.

4T-335 SERIES	4T-335 / 332.....1.18	4T-335 / 332A.....1.27	4T-336 / 332.....1.03	4T-336 / 332A.....1.12	4T-339 / 332.....1.18	4T-339 / 332A.....1.27	4T-342 / 332.....1.03	4T-342 / 332A.....1.11	4T-342A / 332.....1.12	4T-342A / 332A.....1.20	4T-342S / 332......99	4T-342S / 332A.....1.07	4T-344A / 332.....1.06	4T-344A / 332A.....1.15
4T-355 SERIES	4T-355 / 352.....1.49	4T-355 / 354A.....1.13	4T-355 / 354X.....1.13	4T-355X / 352.....1.48	4T-355X / 354A.....1.13	4T-355X / 354X.....1.13	4T-359A / 352.....1.44	4T-359A / 354A.....1.09	4T-359A / 354X.....1.08	4T-359S / 352.....1.44	4T-359S / 354A.....1.09	4T-359S / 354X.....1.09		
4T-365 SERIES	4T-366 / 362.....1.20	4T-366 / 362A.....1.18	4T-366 / 363.....1.27	4T-368 / 362.....1.18	4T-368 / 362A.....1.14	4T-368 / 363.....1.24	4T-368A / 362.....1.16	4T-368A / 362A.....1.14	4T-368A / 363.....1.23	4T-368S / 362.....1.15	4T-368S / 362A.....1.13	4T-368S / 363.....1.22	4T-369A / 362.....1.26	4T-369A / 362A.....1.24
	4T-369A / 363.....1.33	4T-369S / 362.....1.27	4T-369S / 362A.....1.25	4T-369S / 363.....1.34	4T-370A / 362.....1.16	4T-370A / 362A.....1.13	4T-370A / 363.....1.23							
4T-385 SERIES	4T-385 / 382.....1.46	4T-385 / 382A.....1.36	4T-385 / 382S.....1.50	4T-385 / 383A.....1.53	4T-385A / 382.....1.59	4T-385A / 382A.....1.49	4T-385A / 382S.....1.64	4T-385A / 383A.....1.66	4T-385X / 382.....1.46	4T-385X / 382A.....1.35	4T-385X / 382S.....1.50	4T-385X / 383A.....1.52	4T-386A / 382.....1.69	4T-386A / 382A.....1.59
	4T-386A / 382S.....1.73	4T-386A / 383A.....1.76	4T-387 / 382.....1.39	4T-387 / 382A.....1.29	4T-387 / 382S.....1.43	4T-387 / 383A.....1.46	4T-387A / 382.....1.38	4T-387A / 382A.....1.28	4T-387A / 382S.....1.43	4T-387A / 383A.....1.46	4T-387AS / 382.....1.37	4T-387AS / 382A.....1.27	4T-387AS / 382S.....1.42	4T-387AS / 383A.....1.44
	4T-387S / 382.....1.39	4T-387S / 382A.....1.29	4T-387S / 382S.....1.44	4T-387S / 383A.....1.46	4T-388A / 382.....1.37	4T-388A / 382A.....1.27	4T-388A / 382S.....1.41	4T-388A / 383A.....1.44	4T-389A / 382.....1.50	4T-389A / 382A.....1.40	4T-389A / 382S.....1.54	4T-389A / 383A.....1.57		
4T-395 SERIES	4T-390 / 393.....2.41	4T-390 / 394A.....2.10	4T-390 / 394AS.....2.11	4T-395 / 393.....2.17	4T-395 / 394A.....1.87	4T-395 / 394AS.....1.87	4T-395A / 393.....2.06	4T-395A / 394A.....1.75	4T-395A / 394AS.....1.75	4T-395S / 393.....2.05	4T-395S / 394A.....1.74	4T-395S / 394AS.....1.75	4T-396 / 393.....2.64	4T-396 / 394A.....2.35
	4T-396 / 394AS.....2.34	4T-399A / 393.....1.99	4T-399A / 394A.....1.68	4T-399A / 394AS.....1.69	4T-399AS / 393.....1.97	4T-399AS / 394A.....1.67	4T-399AS / 394AS.....1.67							
4T-415 SERIES	4T-418 / 412.....1.77	4T-418 / 414.....1.85	4T-420 / 412.....1.72	4T-420 / 414.....1.79										
4T-435 SERIES	4T-438 / 432A.....2.11	4T-443 / 432A.....2.52												
4T-455 SERIES	4T-455 / 453.....2.86	4T-455 / 453A.....2.73	4T-455 / 453X.....2.62	4T-455 / 454.....3.01	4T-461 / 453.....3.15	4T-461 / 453A.....3.02	4T-461 / 453X.....2.92	4T-461 / 454.....3.31	4T-462 / 453.....2.58	4T-462 / 453A.....2.45	4T-462 / 453X.....2.34	4T-462 / 454.....2.74	4T-467 / 453.....2.98	4T-467 / 453A.....2.85
	4T-467 / 453X.....2.73	4T-467 / 454.....3.14	4T-469 / 453.....2.57	4T-469 / 453A.....2.45	4T-469 / 453X.....2.34	4T-469 / 454.....2.73								
4T-475 SERIES	4T-480 / 472.....3.02	4T-480 / 472A.....2.96	4T-480 / 472X.....3.34	4T-482 / 472.....2.93	4T-482 / 472A.....2.87	4T-482 / 472X.....3.26	4T-483 / 472.....3.26	4T-483 / 472A.....3.21	4T-483 / 472X.....3.59	4T-484 / 472.....2.93	4T-484 / 472A.....2.87	4T-484 / 472X.....3.26		
4T-495 SERIES	4T-495 / 492A.....3.35	4T-495 / 493.....3.60	4T-495A / 492A.....3.75	4T-495A / 493.....4.03	4T-495AX / 492A.....3.73	4T-495AX / 493.....4.01	4T-496 / 492A.....3.45	4T-496 / 493.....3.73	4T-497 / 492A.....3.15	4T-497 / 493.....3.42	4T-498 / 492A.....3.24	4T-498 / 493.....3.53		
4T-525 SERIES	4T-526 / 522.....3.16	4T-527 / 522.....3.02	4T-528 / 522.....2.87	4T-529 / 522.....2.73										
4T-535 SERIES	4T-535 / 532A.....4.09	4T-535 / 532X.....3.71	4T-536 / 532A.....3.94	4T-536 / 532X.....3.56	4T-537 / 532A.....3.79	4T-537 / 532X.....3.42	4T-539 / 532A.....3.64	4T-539 / 532X.....3.24	4T-539A / 532A.....3.62	4T-539A / 532X.....3.24	4T-543 / 532A.....4.28	4T-543 / 532X.....3.90		
4T-555 SERIES	4T-555S / 552.....4.91	4T-555S / 552A.....4.81	4T-555S / 553A.....4.93	4T-555S / 553X.....4.65	4T-557A / 552.....4.69	4T-557A / 552A.....4.58	4T-557A / 553A.....4.70	4T-557A / 553X.....4.42	4T-557S / 552.....5.09	4T-557S / 552A.....4.98	4T-557S / 553A.....5.10	4T-557S / 553X.....4.82	4T-559 / 552.....4.53	4T-559 / 552A.....4.43
	4T-559 / 553A.....4.54	4T-559 / 553X.....4.27	4T-560 / 552.....4.33	4T-560 / 552A.....4.23	4T-560 / 553A.....4.34	4T-560 / 553X.....4.06								
4T-565 SERIES	4T-567 / 563.....4.01													
4T-575 SERIES	4T-575 / 572.....5.35	4T-575 / 572X.....5.32												
4T-575S / 5725.32													
4T-575S / 572X5.28													
4T-576 / 5725.58													
4T-576 / 572X5.55													
4T-577 / 5725.47													
4T-577 / 572X5.43													
4T-580 / 5724.85													
4T-580 / 572X4.82													
4T-581 / 5724.98													
4T-581 / 572X4.95													
4T-582 / 5724.81													
4T-582 / 572X4.78													
4T-595 SERIES	4T-593 / 592.....6.25	4T-593 / 592A.....6.13	4T-593 / 592XS.....5.19	4T-593A / 592.....6.21	4T-593A / 592A.....6.08	4T-593A / 592XS.....5.16	4T-594 / 592.....5.67	4T-594 / 592A.....5.53	4T-594 / 592XS.....4.61	4T-594A / 592.....5.65	4T-594A / 592A.....5.53	4T-594A / 592XS.....4.61	4T-595 / 592.....6.79	4T-595 / 592A.....6.66
	4T-595 / 592XS.....5.73	4T-596 / 592.....6.52	4T-596 / 592A.....6.39	4T-596 / 592XS.....5.47	4T-598 / 592.....5.96	4T-598 / 592A.....5.84	4T-598 / 592XS.....4.91	4T-598A / 592.....5.93	4T-598A / 592A.....5.80	4T-598A / 592XS.....4.87				
4T-615 SERIES	4T-620 / 612.....5.64	4T-621 / 612.....4.87	4T-623 / 612.....4.67											
4T-635 SERIES	4T-635 / 632.....6.71	4T-635 / 633.....5.98	4T-639 / 632.....6.28	4T-639 / 633.....5.55	4T-643 / 632.....5.80	4T-643 / 633.....5.08	4T-645 / 632.....5.65	4T-645 / 633.....4.93						
4T-655 SERIES	4T-659 / 652.....7.53	4T-662 / 652.....6.98	4T-662 / 653.....6.17	4T-665A / 652.....6.63	4T-665 / 652.....6.66									
4T-675 SERIES	4T-681 / 672.....8.53	4T-681A / 672.....8.51	4T-683 / 672.....8.20	4T-683XA / 672.....8.19	4T-685 / 672.....7.85	4T-687 / 672.....7.50								
4T-745 SERIES	4T-745A / 742.....8.64	4T-745A / 743.....8.60	4T-748 / 742.....7.70	4T-748 / 743.....7.63	4T-749 / 742.....7.17	4T-749 / 743.....7.10								



TAPERED ROLLER BEARINGS

LBS.

4T-749A / 742 7.43 4T-749A / 743 7.37 4T-749S / 742 7.14 4T-749S / 743 7.09 4T-750A / 742 7.39 4T-750A / 743 7.33 4T-755 SERIES 4T-756A / 752 10.03 4T-759 / 752 9.02 4T-760 / 752 8.84 4T-766 / 752 8.99 4T-795 SERIES 4T-797 / 792 12.50 4T-855 SERIES 4T-855 / 854 17.33 4T-857 / 854 16.88 4T-861 / 854 15.43 4T-864 / 854 16.41 4T-866 / 854 16.00 4T-869 / 854 17.55 4T-935 SERIES 4T-936 / 932 23.59 4T-938 / 932 22.27 4T-1300 SERIES 4T-1380 / 1328 44 4T-1700 SERIES 4T-1755 / 1729 56 4T-1755 / 1729X 57 4T-1779 / 1729 54 4T-1779 / 1729X 55 4T-1780 / 1729 52 4T-1780 / 1729X 53 4T-1900 SERIES 4T-1986 / 1922 53 4T-1988 / 1922 48 4T-2500 SERIES 4T-2580 / 2523 1.00 4T-2585 / 2523 96 4T-2600 SERIES 4T-2690 / 2631 90 4T-2700 SERIES 4T-2776 / 2720 1.09 4T-2776 / 2729 1.10 4T-2776 / 2735X 97 4T-2777 / 2720 1.08 4T-2777 / 2729 1.09 4T-2777 / 2735X 97 4T-2780 / 2720 1.14 4T-2780 / 2729 1.15 4T-2780 / 2735X 1.03 4T-2788 / 2720 1.09 4T-2788 / 2729 1.10 4T-2788 / 2735X 98 4T-2789 / 2720 1.05 4T-2789 / 2729 1.06 4T-2789 / 2735X 93 4T-2790 / 2720 1.21 4T-2790 / 2729 1.22 4T-2790 / 2735X 1.10 4T-2793 / 2720 1.18 4T-2793 / 2729 1.19 4T-2793 / 2735X 1.06 4T-2794 / 2720 1.13 4T-2794 / 2729 1.14 4T-2794 / 2735X 1.02 4T-2796 / 2720 1.17 4T-2796 / 2729 1.18 4T-2796 / 2735X 1.06	4T-2900 SERIES 4T-2984 / 2924 1.36 4T-3100 SERIES 4T-3193 / 3120 1.32 4T-3196 / 3120 1.28 4T-3300 SERIES 4T-3379 / 3320 1.61 4T-3379 / 3325 1.61 4T-3384 / 3320 1.43 4T-3384 / 3325 1.42 4T-3386 / 3320 1.47 4T-3386 / 3325 1.47 4T-3400 SERIES 4T-3478 / 3420 1.60 4T-3479 / 3420 1.56 4T-3482 / 3420 1.61 4T-3490 / 3420 1.51 4T-3500 SERIES 4T-3578 / 3520 1.54 4T-3578 / 3525 1.72 4T-3578A / 3520 1.53 4T-3578A / 3525 1.71 4T-3580 / 3520 1.77 4T-3580 / 3525 1.94 4T-3585 / 3520 1.66 4T-3585 / 3525 1.84 4T-3586 / 3520 1.51 4T-3586 / 3525 1.69 4T-3700 SERIES 4T-3767 / 3720 1.81 4T-3767 / 3730 1.81 4T-3775 / 3720 1.88 4T-3775 / 3730 1.89 4T-3776 / 3720 2.10 4T-3776 / 3730 2.11 4T-3778 / 3720 1.98 4T-3778 / 3730 1.99 4T-3779 / 3720 2.00 4T-3779 / 3730 2.01 4T-3780 / 3720 1.87 4T-3780 / 3730 1.88 4T-3781 / 3720 1.93 4T-3781 / 3730 1.94 4T-3782 / 3720 2.12 4T-3782 / 3730 2.13 4T-3783 / 3720 2.10 4T-3783 / 3730 2.11 4T-3784 / 3720 1.85 4T-3784 / 3730 1.86 4T-3795 / 3720 1.86 4T-3795 / 3730 1.87 4T-3800 SERIES 4T-3872 / 3820 1.98 4T-3872A / 3820 1.99 4T-3877 / 3820 1.79 4T-3880 / 3820 1.79 4T-3900 SERIES 4T-3979 / 3920 3.09 4T-3979 / 3925 3.12 4T-3982 / 3920 2.78 4T-3982 / 3925 2.80 4T-3984 / 3920 2.60 4T-3984 / 3925 2.62 4T-3994 / 3920 2.60 4T-3994 / 3925 2.61 4T-4300 SERIES 4T-4388 / 4335 2.76	4T-5300 SERIES 4T-5356 / 5335 4.14 4T-5358 / 5335 3.96 4T-5361 / 5335 3.95 4T-5395 / 5335 3.86 4T-5500 SERIES 4T-5562 / 5535 6.16 4T-5565 / 5535 6.02 4T-5566 / 5535 5.71 4T-5578 / 5535 5.82 4T-5582 / 5535 5.39 4T-5583 / 5535 5.38 4T-5584 / 5535 5.14 4T-5595 / 5535 4.96 4T-5700 SERIES 4T-5760 / 5735 6.06 4T-5795 / 5735 5.90 4T-6300 SERIES 4T-6361 / 6320 8.69 4T-6376 / 6320 8.66 4T-6379 / 6320 8.18 4T-6381 / 6320 9.12 4T-6382 / 6320 8.35 4T-6386 / 6320 8.02 4T-6389 / 6320 8.00 4T-6400 SERIES 4T-6461A / 6420 9.33 4T-6500 SERIES 4T-6559 / 6535 11.24 4T-6576 / 6535 11.99 4T-6580 / 6535 10.42 4T-02400 SERIES 4T-02474 / 02420 90 4T-02475 / 02420 84 4T-02800 SERIES 4T-02872 / 02820 1.06 4T-05000 SERIES 4T-05062 / 05185 29 4T-05079 / 05185 26 4T-07000 SERIES 4T-07079 / 07196 30 4T-07079 / 07204 36 4T-07079 / 07210X 34 4T-07087 / 07196 29 4T-07087 / 07204 34 4T-07087 / 07210X 32 4T-07093 / 07196 27 4T-07093 / 07204 33 4T-07093 / 07210X 30 4T-07100 / 07196 26 4T-07100 / 07204 32 4T-07100 / 07210X 29 4T-09000 SERIES 4T-09067 / 09194 43 4T-09067 / 09195 39 4T-09067 / 09196 44 4T-09074 / 09194 45 4T-09074 / 09195 41 4T-09074 / 09196 46 4T-09078 / 09194 45 4T-09078 / 09195 41 4T-09078 / 09196 46 4T-11000 SERIES 4T-11162 / 11300 74 4T-11500 SERIES 4T-11590 / 11520 23	4T-LM11700 SERIES 4T-LM11749 / LM1171019 4T-LM11900 SERIES 4T-LM11949 / LM1191027 4T-12000 SERIES 4T-12175 / 1230368 4T-12500 SERIES 4T-12580 / 1252040 4T-M12600 SERIES 4T-M12649 / M1261037 4T-LM12700 SERIES 4T-LM12749 / LM1271026 4T-LM12749 / LM1271127 4T-13600 SERIES 4T-13685 / 1362065 4T-13685 / 1362165 4T-13686 / 1362084 4T-13686 / 1362184 4T-13687 / 1362066 4T-13687 / 1362165 4T-14000 SERIES 4T-14116 / 1427481 4T-14116 / 1427682 4T-14116 / 1428288 4T-14116 / 1428399 4T-14117A / 1427481 4T-14117A / 1427681 4T-14117A / 1428288 4T-14117A / 1428398 4T-14118 / 1427481 4T-14118 / 1427682 4T-14118 / 1428288 4T-14118 / 1428398 4T-14124 / 1427478 4T-14124 / 1427679 4T-14124 / 1428286 4T-14124 / 1428396 4T-14125A / 1427478 4T-14125A / 1427678 4T-14125A / 1428285 4T-14125A / 1428395 4T-14131 / 1427476 4T-14131 / 1427676 4T-14131 / 1428283 4T-14131 / 1428393 4T-14136A / 1427486 4T-14136A / 1427687 4T-14136A / 1428293 4T-14136A / 14283 1.04 4T-14137A / 1427473 4T-14137A / 1427673 4T-14137A / 1428280 4T-14137A / 1428390 4T-14138A / 1427472 4T-14138A / 1427673 4T-14138A / 1428279 4T-14138A / 1428390 4T-15000 SERIES 4T-15100 / 1524366 4T-15100 / 1524469 4T-15100 / 1524566 4T-15100 / 1525073 4T-15100 / 15250X73 4T-15101 / 1524366 4T-15101 / 1524470 4T-15101 / 1524567 4T-15101 / 1525073 4T-15101 / 15250X73 4T-15103S / 1524364
---	--	---	---

Continued next page ...



Bearing Series

→ 4T-335 SERIES

4T-335 / 332.....

1.18 ←

Cone Number

Cup Number

Weight (lbs)

TAPERED ROLLER BEARINGS

LBS.

4T-15103S / 15244	.68
4T-15103S / 15245	.65
4T-15103S / 15250	.72
4T-15103S / 15250X	.72
4T-15106 / 15243	.64
4T-15106 / 15244	.67
4T-15106 / 15245	.64
4T-15106 / 15250	.71
4T-15106 / 15250X	.71
4T-15113 / 15243	.62
4T-15113 / 15244	.65
4T-15113 / 15245	.62
4T-15113 / 15250	.69
4T-15113 / 15250X	.69
4T-15116 / 15243	.59
4T-15116 / 15244	.62
4T-15116 / 15245	.59
4T-15116 / 15250	.66
4T-15116 / 15250X	.66
4T-15117 / 15243	.59
4T-15117 / 15244	.62
4T-15117 / 15245	.59
4T-15117 / 15250	.67
4T-15117 / 15250X	.66
4T-15118 / 15243	.58
4T-15118 / 15244	.62
4T-15118 / 15245	.58
4T-15118 / 15250	.66
4T-15118 / 15250X	.66
4T-15119 / 15243	.59
4T-15119 / 15244	.62
4T-15119 / 15245	.59
4T-15119 / 15250	.66
4T-15119 / 15250X	.66
4T-15120 / 15243	.59
4T-15120 / 15244	.62
4T-15120 / 15245	.59
4T-15120 / 15250	.66
4T-15120 / 15250X	.66
4T-15123 / 15243	.54
4T-15123 / 15244	.58
4T-15123 / 15245	.54
4T-15123 / 15250	.62
4T-15123 / 15250X	.62
4T-15125 / 15243	.56
4T-12125 / 15244	.59
4T-15125 / 15245	.56
4T-15125 / 15250	.63
4T-15125 / 15250X	.63
4T-15126 / 15243	.56
4T-15126 / 15244	.60
4T-15126 / 15245	.56
4T-15126 / 15250	.63
4T-15126 / 15250X	.63
4T-15500 SERIES	
4T-15578 / 15520	.48
4T-15580 / 15520	.46
4T-15590 / 15520	.43
4T-16000 SERIES	
4T-16150 / 16284	.72
4T-16150 / 16284	.77
4T-17000 SERIES	
4T-17118 / 17244	.50
4T-17500 SERIES	
4T-17580 / 17520	.27
4T-17800 SERIES	
4T-17887 / 17831	.89
4T-18500 SERIES	
4T-18590 / 18520	.62

4T-18600 SERIES	
4T-18685 / 18620	.76
4T-18690 / 18620	.73
4T-18700 SERIES	
4T-18780 / 18720	.94
4T-18790 / 18720	.82
4T-19000 SERIES	
4T-19150 / 19268	.53
4T-19150 / 19268X	.62
4T-19150 / 19283X	.66
4T-21000 SERIES	
4T-21075 / 21212	.55
4T-22700 SERIES	
4T-22780 / 22720	1.36
4T-23000 SERIES	
4T-23100 / 23250X	.73
4T-24700 SERIES	
4T-24780 / 24720	.95
4T-24780 / 24721	1.04
4T-24780 / 24722	.95
4T-25500 SERIES	
4T-25577 / 25519	1.26
4T-25577 / 25520	1.27
4T-25577 / 25521	1.28
4T-25577 / 25522	1.29
4T-25577 / 25523	1.38
4T-25577 / 25526	1.37
4T-25578 / 25519	1.27
4T-25578 / 25520	1.29
4T-25578 / 25521	1.28
4T-25578 / 25522	1.24
4T-25578 / 25523	1.39
4T-25578 / 25526	1.46
4T-25580 / 25519	1.21
4T-25580 / 25520	1.23
4T-25580 / 25521	1.23
4T-25580 / 25522	1.24
4T-25580 / 25523	1.33
4T-25580 / 25526	1.32
4T-25583 / 25519	1.20
4T-25583 / 25520	1.20
4T-25583 / 25521	1.20
4T-25583 / 25522	1.20
4T-25583 / 25523	1.20
4T-25583 / 25526	1.20
4T-25584 / 25519	1.20
4T-25584 / 25520	1.22
4T-25584 / 25521	1.22
4T-25584 / 25522	1.23
4T-25584 / 25523	1.32
4T-25584 / 25526	1.32
4T-25590 / 25519	1.18
4T-25590 / 25520	1.20
4T-25590 / 25521	1.19
4T-25590 / 25522	1.19
4T-25590 / 25523	1.20
4T-25590 / 25526	1.24
4T-25800 SERIES	
4T-25877 / 25820	1.02
4T-25877 / 25821	1.03
4T-25878 / 25820	1.03
4T-25878 / 25821	1.04
4T-25880 / 25820	1.00
4T-25880 / 25821	1.01
4T-26800 SERIES	
4T-26878 / 26820	1.34
4T-26878 / 26822	1.27
4T-26878 / 26823	1.17

4T-26878 / 26830	1.35
4T-26881 / 26820	1.29
4T-26881 / 26822	1.22
4T-26881 / 26823	1.12
4T-26881 / 26830	1.30
4T-26882 / 26820	1.23
4T-26882 / 26822	1.17
4T-26882 / 26823	1.08
4T-26882 / 26830	1.26
4T-26883 / 26820	1.42
4T-26883 / 26822	1.35
4T-26883 / 26823	1.25
4T-26883 / 26830	1.43
4T-26884 / 26820	1.20
4T-26884 / 26822	1.12
4T-26884 / 26823	1.03
4T-26884 / 26830	1.21
4T-26886 / 26820	1.20
4T-26886 / 26822	1.13
4T-26886 / 26823	1.04
4T-26886 / 26830	1.21
4T-27800 SERIES	
4T-27881 / 27820	1.23
4T-28000 SERIES	
4T-28150 / 28300	.89
4T-28500 SERIES	
4T-28580 / 28520	1.45
4T-28580 / 28521	1.55
4T-28584 / 28520	1.39
4T-28584 / 28521	1.01
4T-28600 SERIES	
4T-28678 / 28621	1.84
4T-28678 / 28622	1.88
4T-28682 / 28621	1.61
4T-28682 / 28622	1.65
4T-28900 SERIES	
4T-28980 / 28920	1.80
4T-28980 / 28921	1.71
4T-28985 / 28920	1.78
4T-28985 / 28921	1.70
4T-29500 SERIES	
4T-29585 / 29520	2.04
4T-29600 SERIES	
4T-29675 / 29620	2.09
4T-29675 / 29630	2.58
4T-29685 / 29620	1.92
4T-29685 / 29630	2.41
4T-LM29700 SERIES	
4T-LM29748 / LM29710	.51
4T-31500 SERIES	
4T-31593 / 31520	1.38
4T-31594 / 31520	1.38
4T-31597 / 31520	1.33
4T-33000 SERIES	
4T-33225 / 33462	3.48
4T-33225 / 33472	3.66
4T-33262 / 33462	2.99
4T-33262 / 33472	3.18
4T-33275 / 33462	2.82
4T-33275 / 33472	3.00
4T-33281 / 33462	2.73
4T-33281 / 33472	2.91
4T-33287 / 33462	2.63
4T-33287 / 33472	2.82
4T-33800 SERIES	
4T-33891 / 33821	1.87

4T-34000 SERIES	
4T-34306 / 34478	2.08
4T-34306 / 34492A	2.22
4T-39500 SERIES	
4T-39581 / 39520	3.11
4T-39585 / 39520	2.80
4T-39590 / 39520	2.63
4T-41000 SERIES	
4T-41125 / 41286	1.05
4T-42000 SERIES	
4T-42346 / 42584	4.37
4T-42346 / 42587	4.72
4T-42350 / 42584	4.32
4T-42350 / 42587	4.65
4T-42368 / 42584	3.97
4T-42368 / 42587	4.31
4T-42375 / 42584	3.86
4T-42375 / 42587	4.19
4T-42381 / 42584	3.73
4T-42381 / 42587	4.07
4T-42600 SERIES	
4T-42687 / 42620	3.22
4T-43000 SERIES	
4T-43131 / 43300	1.10
4T-44000 SERIES	
4T-44150 / 44348	1.57
4T-L44600 SERIES	
4T-L44640 / L44610	.30
4T-L44643 / L44610	.29
4T-L44649 / L44610	.27
4T-45200 SERIES	
4T-45282 / 45220	2.84
4T-45284 / 45220	2.69
4T-L45400 SERIES	
4T-L45449 / L45410	.25
4T-46000 SERIES	
4T-46143 / 46368	2.56
4T-46143 / 46369	2.57
4T-46162 / 46368	2.40
4T-46162 / 46369	2.42
4T-46700 SERIES	
4T-46790 / 46720	10.32
4T-47600 SERIES	
4T-47678 / 47620	4.23
4T-47678 / 47623A	4.25
4T-47679 / 47620	4.26
4T-47679 / 47623A	4.28
4T-47681 / 47620	3.92
4T-47681 / 47623A	4.28
4T-47686 / 47620	3.79
4T-47686 / 47623A	3.81
4T-47687 / 47620	3.77
4T-47687 / 47623A	3.79
4T-47800 SERIES	
4T-47890 / 47820	4.59
4T-47896 / 47820	4.30
4T-LM48500 SERIES	
4T-LM48548 / LM48510	.55
4T-48600 SERIES	
4T-48684 / 48620	8.49
4T-49000 SERIES	
4T-49175 / 49368	2.22
4T-49500 SERIES	
4T-49585 / 49520	2.49



TAPERED ROLLER BEARINGS

LBS.

<p>4T-52000 SERIES</p> <p>4T-52387 / 526185.78 4T-52387 / 526386.70 4T-52400 / 526185.47 4T-52400 / 526386.37 4T-52401 / 526185.41 4T-52401 / 526386.32</p> <p>4T-55000C SERIES</p> <p>4T-55175C / 554373.20 4T-55200C / 554372.97</p> <p>4T-56000 SERIES</p> <p>4T-56425 / 566505.93</p> <p>4T-59000 SERIES</p> <p>4T-59162 / 594293.85 4T-59200 / 594293.41</p> <p>4T-65300 SERIES</p> <p>4T-65390 / 653204.92</p> <p>4T-LM67000 SERIES</p> <p>4T-LM67048 / LM6701040</p> <p>4T-67300 SERIES</p> <p>4T-67388 / 6732211.24 4T-67388 / 6732413.08</p> <p>4T-L68100 SERIES</p> <p>4T-L68149 / L6811038 4T-L68149 / L6811139</p> <p>4T-L69300 SERIES</p> <p>4T-JL69349 / JL6931044</p> <p>4T-72000C SERIES</p> <p>4T-72188C / 724874.76 4T-72200C / 724874.63</p> <p>4T-78000C SERIES</p> <p>4T-78215C / 785516.09 4T-78225C / 785515.93 4T-78238C / 785515.74</p> <p>4T-LM78300 SERIES</p> <p>4T-LM78349 / LM78310A46</p> <p>4T-HM81600 SERIES</p> <p>4T-HM81649 / HM8161043</p> <p>4T-M84200 SERIES</p> <p>4T-M84249 / M8421071</p> <p>4T-M84500 SERIES</p> <p>4T-M84548 / M8451053</p> <p>4T-M86600 SERIES</p> <p>4T-M86649 / M8661074</p> <p>4T-M88000 SERIES</p> <p>4T-M88048 / M8801083</p>	<p>4T-HM88500 SERIES</p> <p>4T-HM88542 / HM885101.37 4T-HM88547 / HM885101.33</p> <p>4T-HM88600 SERIES</p> <p>4T-HM88649 / HM886101.08 4T-HM88649 / HM886111.12</p> <p>4T-HM89400 SERIES</p> <p>4T-HM89443 / HM894101.47 4T-HM89443 / HM894111.48 4T-HM89446 / HM894101.42 4T-HM89446 / HM894111.44 4T-HM89448 / HM894101.39 4T-HM89448 / HM894111.40 4T-HM89449 / HM894101.37 4T-HM89449 / HM894111.39</p> <p>4T-LM102900 SERIES</p> <p>4T-LM102949 / LM10291068</p> <p>4T-LM104900 SERIES</p> <p>4T-LM104949 / LM10491192 4T-JLM104948 / JLM10491093 4T-LM104949 / LM10491192 4T-JLM104948 / JLM10491093</p> <p>4T-M201000 SERIES</p> <p>4T-M201047 / M20101195</p> <p>4T-M205100 SERIES</p> <p>4T-JM205149 / JM2051101.66</p> <p>4T-M20700 SERIES</p> <p>4T-JM207049 / JM2070101.81</p> <p>4T-H211700 SERIES</p> <p>4T-JH211749 / JH211704.19</p> <p>4T-HM212000 SERIES</p> <p>4T-HM212044 / HM2120104.49 4T-HM212044 / HM2120114.45 4T-HM212046 / HM2120104.32 4T-HM212046 / HM2120114.30 4T-HM212047 / HM2120104.29 4T-HM212047 / HM2120114.28 4T-HM212049 / HM2120104.11 4T-HM212049 / HM2120114.09</p> <p>4T-H212700 SERIES</p> <p>4T-H212749 / 2127104.80</p> <p>4T-L217800 SERIES</p> <p>4T-L217849 / L2178101.63</p> <p>4T-HM218200 SERIES</p> <p>4T-HM218248 / HM2182105.62</p> <p>4T-HM220100 SERIES</p> <p>4T-HM220149 / HM2201106.31</p>	<p>4T-LM300800 SERIES</p> <p>4T-LM300849 / LM30081153</p> <p>4T-H307700 SERIES</p> <p>4T-JH307749 / JH3077103.77</p> <p>4T-LM501300 SERIES</p> <p>4T-LM501349 / LM50131074 4T-LM501349 / LM50131478</p> <p>4T-LM503300 SERIES</p> <p>4T-LM503349 / LM50331066</p> <p>4T-HH506300 SERIES</p> <p>4T-HH506348 / HH5063105.14</p> <p>4T-LM506800 SERIES</p> <p>4T-JLM506849 / JLM5068101.23</p> <p>4T-LM508700 SERIES</p> <p>4T-JLM508748 / JLM5087101.34</p> <p>4T-M511900 SERIES</p> <p>4T-JM511946 / JM5119102.38</p> <p>4T-HM516400 SERIES</p> <p>4T-HM516448 / HM5164104.76</p> <p>4T-M515600 SERIES</p> <p>4T-JM515649 / JM5156103.81</p> <p>4T-HM515700 SERIES</p> <p>4T-HM515745 / HM5157166.75</p> <p>4T-HM516800 SERIES</p> <p>4T-JHM516849 / JHM5168105.07</p> <p>4T-HM518400 SERIES</p> <p>4T-HM518445 / HM5184106.39</p> <p>4T-HM522600 SERIES</p> <p>4T-JHM522649 / JHM52261010.20</p> <p>4T-LM603000 SERIES</p> <p>4T-LM603049 / LM60301182</p> <p>4T-LM612900 SERIES</p> <p>4T-JM612949 / JM6129102.49</p> <p>4T-HM617000 SERIES</p> <p>4T-HM617049 / HM6170105.93</p> <p>4T-M704600 SERIES</p> <p>4T-JLM704649 / JLM7046101.03</p> <p>4T-LM710900 SERIES</p> <p>4T-JLM710949 / JLM7109101.64</p> <p>4T-M714200 SERIES</p> <p>4T-JM714249 / JM7142102.84</p> <p>4T-H715300 SERIES</p> <p>4T-H715343 / H7153117.13 4T-H715343 / H715313W7.35 4T-H715345 / H7153116.85 4T-H715345 / H715313W7.07</p>	<p>4T-M716600 SERIES</p> <p>4T-JM716649 / JM7166103.06</p> <p>4T-M718100 SERIES</p> <p>4T-JM718149 / JM7181104.72</p> <p>4T-M719100 SERIES</p> <p>4T-JM719149 / JM7191134.83</p> <p>4T-HM720200 SERIES</p> <p>4T-JHM720249 / JHM7202106.70</p> <p>4T-M736100 SERIES</p> <p>4T-JM736149 / JM73611014.90</p> <p>4T-LM739700 SERIES</p> <p>4T-LM739749 / LM7397101.17</p> <p>4T-HM801300 SERIES</p> <p>4T-HM801346 / HM8013101.70</p> <p>4T-M802000 SERIES</p> <p>4T-M802048 / M8020111.42</p> <p>4T-HM803100 SERIES</p> <p>4T-HM803146 / HM8031101.98 4T-HM803149 / HM8031101.87</p> <p>4T-M804000 SERIES</p> <p>4T-M804049 / M8040101.45</p> <p>4T-HM804800 SERIES</p> <p>4T-HM804846 / HM8048102.16 4T-HM804848 / HM8048102.13</p> <p>4T-LM806600 SERIES</p> <p>4T-LM806649 / LM80661096</p> <p>4T-HM807000 SERIES</p> <p>4T-HM807040 / HM8070103.57 4T-HM807044 / HM8070103.35 4T-HM807046 / HM8070103.29 4T-HM807049 / HM8070103.11</p> <p>4T-LM813000 SERIES</p> <p>4T-JLM813049 / JLM8130101.96</p> <p>4T-HM813800 SERIES</p> <p>4T-HM813840 / HM8138105.16 4T-HM813841 / HM8138104.87</p> <p>4T-M822000 SERIES</p> <p>4T-JM822049 / JM8220105.56</p> <p>4T-HM903200 SERIES</p> <p>4T-HM903249 / HM9032102.21 4T-HM903249A / HM9032102.20</p>
--	---	---	---



Units: INCHES
Millimeters

TAPERED ROLLER BEARINGS

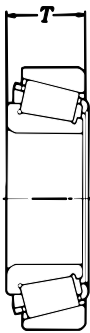
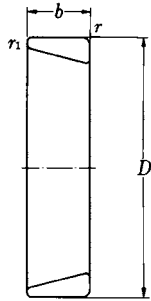
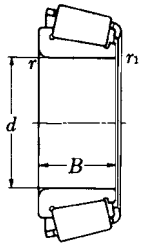

Bearing No.	Bore	O.D.	Overall Width	Cone Width	Cup Width	Fillet Radii		Basic Load Ratings (lbs)	
	<i>d</i>	<i>D</i>	<i>T</i>	<i>B</i>	<i>b</i>	<i>r</i>	<i>r₁</i>	Dynamic <i>C</i>	Static <i>C₀</i>
4T-30208	1.5748 40	3.1496 80	.7776 19.75	.7087 18	.6299 16	.039 1.0	.039 1.0	13,800	15,100
4T-30209	1.7717 45	3.3465 85	.8169 20.75	.7480 19	.6299 16	.039 1.0	.039 1.0	15,200	17,600
4T-30210	1.9685 50	3.5433 90	.8563 21.75	.7874 20	.6693 17	.039 1.0	.039 1.0	17,400	20,900
4T-30211	2.1654 55	3.9370 100	.8957 22.75	.8268 21	.7087 18	.059 1.5	.039 1.0	20,900	24,900
4T-30212	2.3622 60	4.3307 110	.9350 23.75	.8661 22	.7480 19	.059 1.5	.039 1.0	23,500	28,000
4T-30213	2.5591 65	4.7244 120	.9744 24.75	.9055 23	.7874 20	.059 1.5	.039 1.0	27,700	33,000
4T-30214	2.7559 70	4.9213 125	1.0335 26.25	.9449 24	.8268 21	.059 1.5	.039 1.0	29,500	36,500
4T-30215	2.9528 75	5.1181 130	1.0728 27.25	.9843 25	.8661 22	.059 1.5	.059 1.0	31,000	39,500
30216U	3.1496 80	5.5118 140	1.1122 28.25	1.0236 26	.8661 22	.079 2.0	.059 1.5	36,000	45,000
30217U	3.3465 85	5.9055 150	1.2008 30.5	1.1024 28	.9449 24	.079 2.0	.059 1.5	41,000	52,000
30218U	3.5433 90	6.2992 160	1.2795 32.5	1.1811 30	1.0236 26	.079 2.0	.059 1.5	46,500	60,000
30219U	3.7402 95	6.6929 170	1.3583 34.5	1.2598 32	1.0630 27	.098 2.5	.079 2.0	51,000	65,000
30220U	3.9370 100	7.0866 180	1.4567 37	1.3386 34	1.1417 29	.098 2.5	.079 2.0	58,000	75,500
30221U	4.1339 105	7.4803 190	1.5354 39	1.4173 36	1.1811 30	.098 2.5	.079 2.0	64,500	85,000
30222U	4.3307 110	7.8740 200	1.6142 41	1.4961 38	1.2598 32	.098 2.5	.079 2.0	72,500	97,500
30224U	4.7244 120	8.4646 215	1.7126 43.5	1.5748 40	1.3386 34	.098 2.5	.079 2.0	78,000	106,000
30226U	5.1181 130	9.0551 230	1.7224 43.75	1.5748 40	1.3386 34	.118 3.0	.098 2.5	84,000	113,000
30228*	5.5118 140	9.8425 250	1.8012 45.75	1.6535 42	1.4173 36	.098 2.5	.098 2.5	84,000	109,000
30230U	5.9055 150	10.6299 270	1.9291 49	1.7717 45	1.4961 38	.118 3.0	.098 2.5	101,000	136,000
30232U	6.2992 160	11.4173 290	2.0472 52	1.8898 48	1.5748 40	.118 3.0	.098 2.5	118,000	162,000
30234U	6.6929 170	12.2047 310	2.2441 57	2.0472 52	1.6929 43	.157 4.0	.118 3.0	137,700	190,000
30236*	7.0866 180	12.5984 320	2.2441 57	2.0472 52	1.6929 43	.118 3.0	.118 3.0	126,000	162,000
30238U	7.4803 190	13.3858 340	2.3622 60	2.1654 55	1.8110 46	.157 4.0	.118 3.0	161,000	226,000
30240*	7.8740 200	14.1732 360	2.5197 64	2.2835 58	1.8898 48	.118 3.0	.118 3.0	152,000	223,000
4T-30306	1.1811 30	2.8346 72	.8169 20.75	.7480 19	.6299 16	.039 1.0	.039 1.0	13,500	13,700
4T-30307	1.3780 35	3.1496 80	.8957 22.75	.8268 21	.7087 18	.059 1.5	.039 1.0	16,800	17,400
4T-30307D	1.3780 35	3.1496 80	.8957 22.75	.8268 21	.5906 15	.059 1.5	.039 1.0	14,300	15,700
4T-30308	1.5748 40	3.5433 90	.9941 25.25	.9055 23	.7874 20	.059 1.5	.039 1.0	20,600	22,900
4T-30308D	1.5748 40	3.5433 90	.9941 25.25	.9055 23	.6693 17	.059 1.5	.039 1.0	17,300	19,200
4T-30309	1.7717 45	3.9370 100	1.0728 27.25	.9843 25	.8661 22	.059 1.5	.039 1.0	25,000	28,300
4T-30309D	1.7717 45	3.9370 100	1.0728 27.25	.9843 25	.7087 18	.059 1.5	.039 1.0	21,600	24,500
4T-30310	1.9685 50	4.3307 110	1.1516 29.25	1.0630 27	.9055 23	.079 2.0	.059 1.5	29,800	34,000
4T-30310D	1.9685 50	4.3307 110	1.1516 29.25	1.0630 27	.7480 19	.079 2.0	.059 1.5	25,500	29,300
4T-30311	2.1654 55	4.7244 120	1.2402 31.5	1.1417 29	.9843 25	.079 2.0	.059 1.5	35,000	40,500
4T-30311D	2.1654 55	4.7244 120	1.2402 31.5	1.1417 29	.8268 21	.079 2.0	.059 1.5	29,700	34,500
4T-30312D	2.3622 60	5.1181 130	1.3189 33.5	1.2205 31	.8661 22	.098 2.5	.079 2.0	34,000	39,500
30312U	2.3622 60	5.1181 130	1.3189 33.5	1.2205 31	1.0236 26	.098 2.5	.079 2.0	40,500	47,000
4T-30313D	2.5591 65	5.5118 140	1.4173 36	1.2992 33	.9055 23	.098 2.5	.079 2.0	39,000	46,000

* These bearings do not adopt subunit size.

TAPERED ROLLER BEARINGS

Units: INCHES
Millimeters

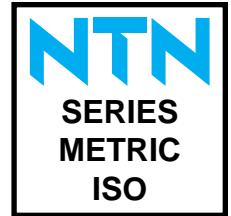

Bearing No.	Bore		Overall Width <i>T</i>	Cone Width <i>B</i>	Cup Width <i>b</i>	Fillet Radii		Basic Load Ratings (lbs)	
	<i>d</i>	<i>D</i>				<i>r</i>	<i>r_i</i>	Dynamic <i>C</i>	Static <i>C₀</i>
30313U	2.5591	5.5118	1.4173	1.2992	1.1024	.098	.079	45,500	53,500
4T-30314D	65	140	36	33	28	2.5	2.0	43,500	51,500
	70	150	38	35	25	2.5	2.0		
30314U	2.7559	5.9055	1.4961	1.3780	1.1811	.098	.079	51,500	61,000
30315DU	70	150	38	35	30	2.5	2.0	48,500	57,500
	75	160	40	37	26	2.5	2.0		
30315U	2.9528	6.2992	1.5748	1.4567	1.2205	.098	.079	57,500	68,000
30316DU	75	160	40	37	31	2.5	2.0	53,000	63,500
	80	170	42.5	39	27	2.5	2.0		
30316U	3.1496	6.6929	1.6732	1.5354	1.2992	.098	.079	65,500	79,000
30317DU	80	170	42.5	39	33	2.5	2.0	55,500	66,000
	85	180	44.5	41	28	3.0	2.5		
30317U	3.3465	7.0866	1.7520	1.6142	1.1024	.118	.098	68,500	81,500
30318DU	85	180	44.5	41	34	3.0	2.5	61,000	72,500
	90	190	46.5	43	30	3.0	2.5		
30318U	3.5433	7.4803	1.8307	1.6929	1.1811	.118	.098	76,000	91,500
30319*	90	190	46.5	43	36	3.0	2.5	71,000	82,500
	95	200	49.5	45	38	2.5	2.5		
30319DU	3.7402	7.8740	1.9488	1.7717	1.2598	.118	.098	66,500	80,000
30320*	95	200	49.5	45	32	3.0	2.5	75,000	86,000
	100	215	51.5	47	39	2.5	2.5		
30321*	3.9370	8.4646	2.0276	1.8504	1.5354	.098	.098	82,000	94,500
30322*	100	215	51.5	47	41	2.5	2.5	89,500	104,000
	110	240	54.5	50	42	2.5	2.5		
30324*	4.1339	8.8583	2.1063	1.9291	1.6142	.098	.098	105,000	123,000
30326*	105	225	53.5	49	41	2.5	2.5	118,000	140,000
	120	260	59.5	55	46	2.5	2.5		
30328*	4.7244	10.2362	2.3425	2.1654	1.8110	.098	.098	144,000	176,000
30330*	120	260	59.5	55	46	2.5	2.5	153,000	197,000
	130	280	63.75	58	49	3.0	3.0		
30332*	5.1181	11.0236	2.5098	2.2835	1.9291	.118	.118	170,000	219,000
30334*	130	280	63.75	58	49	3.0	3.0	190,000	248,000
	140	300	67.75	62	53	3.0	3.0		
31320XU	5.9055	12.5984	2.8346	2.5591	2.1654	.118	.118	79,500	97,500
31321XU	150	320	72	65	55	3.0	3.0	85,500	105,000
	160	340	75	68	58	3.0	3.0		
31322XU	6.2992	13.3858	2.9528	2.6772	2.2835	.118	.118	97,000	120,000
31324XU	160	340	75	68	58	3.0	3.0	116,000	147,000
	170	360	80	72	62	3.0	3.0		
31326XU	3.9370	8.4646	2.2244	2.0079	1.3780	.118	.098	135,000	176,000
31328XU	100	215	56.5	51	35	3.0	2.5	154,000	204,000
	105	225	58	53	36	3.0	2.5		
31330XU	4.1339	8.8583	2.2835	2.0866	1.4173	.118	.098	175,000	232,000
32016XU	4.3307	9.4488	2.4803	2.2441	1.4961	.118	.098	31,500	48,500
	110	240	63	57	38	3.0	2.5		
32017XU	4.7244	10.2362	2.6772	2.4409	1.6535	.118	.098	32,000	50,500
32018XU	120	260	68	62	42	3.0	2.5	38,000	61,000
	130	280	72	66	44	4.0	3.0		
32019XU	5.1181	11.0236	2.8346	2.5984	1.7323	.157	.118	38,500	63,000
32020XU	130	280	72	66	44	4.0	3.0	38,000	63,000
	140	300	77	70	47	4.0	3.0		
32021XU	5.9055	12.5984	3.2283	2.9528	1.9685	.157	.118	45,000	75,000
32022XU	150	320	82	75	50	4.0	3.0	53,000	87,500
	160	340	85	78	53	4.0	3.0		
32024XU	3.1496	4.9213	1.1417	1.1417	.8661	.039	.039	55,000	94,500
32026XU	80	125	29	29	22	1.0	1.0	71,500	122,000
	85	130	29	29	22	1.0	1.0		
32018XU	3.3465	5.1181	1.1417	1.1417	.8661	.039	.039	38,000	61,000
32019XU	90	140	32	32	24	1.5	1.0	38,500	63,000
	95	145	32	32	24	1.5	1.0		
32020XU	3.7402	5.7087	1.2598	1.2598	.9449	.059	.039	38,000	63,000
32021XU	100	150	32	32	24	1.5	1.0	45,000	75,000
	105	160	35	35	26	2.0	1.5		
32022XU	4.1339	6.2992	1.3780	1.3780	1.0236	.079	.059	53,000	87,500
32024XU	110	170	38	38	29	2.0	1.5	55,000	94,500
	120	180	38	38	29	2.0	1.5		
32026XU	5.1181	7.8740	1.7717	1.7717	1.3386	.079	.059	71,500	122,000
	130	200	45	45	34	2.0	1.5		

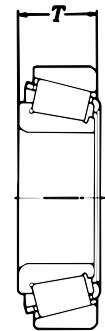
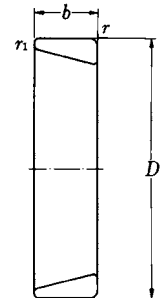
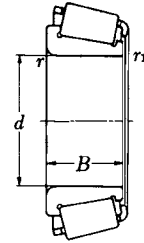

* These bearings do not adopt subunit size.



Units: INCHES
Millimeters

TAPERED ROLLER BEARINGS

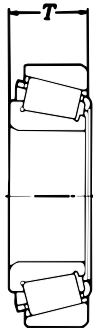
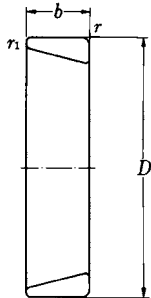
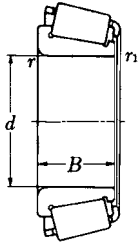

Bearing No.	Bore		O.D.		Overall Width		Cone Width		Cup Width		Fillet Radii		Basic Load Ratings (lbs)	
	<i>d</i>	<i>D</i>	<i>T</i>	<i>B</i>	<i>b</i>	<i>r</i>	<i>r₁</i>	Dynamic <i>C</i>	Static <i>C₀</i>					
32028XU	5.5118 140	8.2677 210	1.7717 45	1.7717 45	1.3386 34	.079 2.0	.059 1.5	74,500	131,000					
32030XU	5.9055 150	8.8583 225	1.8898 48	1.8898 48	1.4173 36	.098 2.5	.079 2.0	83,000	147,000					
32032XU	6.2992 160	9.4488 240	2.0079 51	2.0079 51	1.4961 38	.098 2.5	.079 2.0	98,000	178,000					
32034XU	6.6929 170	10.2362 260	2.2441 57	2.2441 57	1.6929 43	.098 2.5	.079 2.0	112,000	201,000					
32036XU	7.0866 180	11.0236 280	2.5197 64	2.5197 64	1.8898 48	.098 2.5	.079 2.0	145,000	262,000					
32038XU	7.4803 190	11.4173 290	2.5197 64	2.5197 64	1.8898 48	.098 2.5	.079 2.0	148,000	272,000					
32040XU	7.8740 200	12.2047 310	2.7559 70	2.7559 70	2.0866 53	.098 2.5	.079 2.0	180,000	330,000					
32044XU	8.6614 220	13.3858 340	2.9921 76	2.9921 76	2.2441 57	.118 3.0	.098 2.5	207,000	380,000					
32048XU	9.4488 240	14.1732 360	2.9921 76	2.9921 76	2.2441 57	.118 3.0	.098 2.5	209,000	395,000					
32052XU	10.2362 260	15.7480 400	3.4252 87	3.4252 87	2.5591 65	.157 4.0	.118 3.0	271,000	510,000					
32056XU	11.0236 280	16.5354 420	3.4252 87	3.4252 87	2.5591 65	.157 4.0	.118 3.0	275,000	530,000					
32060XU	11.8110 300	18.1102 460	3.9370 100	3.9370 100	2.9134 74	.157 4.0	.118 3.0	335,000	635,000					
32064XU	12.5984 320	18.8976 480	3.9370 100	3.9370 100	2.9134 74	.157 4.0	.118 3.0	340,000	660,000					
4T-32203R*	.6693 17	1.5748 40	.6791 17.25	.6299 16	.5512 14	.024 .6	.024 .6	5,900	6,350					
4T-32205R*	.9843 25	2.0472 52	.7579 19.25	.7087 18	.5906 15	.024 .6	.024 .6	8,550	9,650					
4T-32208	1.5748 40	3.1496 80	.9744 24.75	.9055 23	.7480 19	.039 1.0	.039 1.0	17,800	21,000					
4T-32209	1.7717 45	3.3465 85	.9744 24.75	.9055 23	.7480 19	.039 1.0	.039 1.0	18,400	22,500					
4T-32210	1.9685 50	3.5433 90	.9744 24.75	.9055 23	.7480 19	.039 1.0	.039 1.0	19,700	24,500					
4T-32211	2.1654 55	3.9370 100	1.0531 26.75	.9843 25	.8268 21	.059 1.5	.039 1.0	24,300	30,000					
32212U	2.3622 60	4.3307 110	1.1713 29.75	1.1024 28	.9449 24	.059 1.5	.039 1.0	29,200	37,000					
32213U	2.5591 65	4.7244 120	1.2894 32.75	1.2205 31	1.0630 27	.059 1.5	.039 1.0	35,500	46,000					
32214U	2.7559 70	4.9213 125	1.3091 33.25	1.2205 31	1.0630 27	.059 1.5	.039 1.0	37,500	49,500					
32215U	2.9528 75	5.1181 130	1.3091 33.25	1.2205 31	1.0630 27	.059 1.5	.039 1.0	37,500	50,500					
32216U	3.1496 80	5.5118 140	1.3878 35.25	1.2992 33	1.1024 28	.079 2.0	.059 1.5	44,500	59,500					
32217U	3.3465 85	5.9055 150	1.5157 38.5	1.4173 36	1.1811 30	.079 2.0	.059 1.5	50,500	67,500					
32218U	3.5433 90	6.2992 160	1.6732 42.5	1.5748 40	1.3386 34	.079 2.0	.059 1.5	59,000	81,000					
32219U	3.7402 95	6.6929 170	1.7913 45.5	1.6929 43	1.4567 37	.098 2.5	.079 2.0	67,500	93,500					
32220U	3.9370 100	7.0866 180	1.9291 49	1.8110 46	1.5354 39	.098 2.5	.079 2.0	74,500	104,000					
32221U	4.1339 105	7.4803 190	2.0866 53	1.9685 50	1.6929 43	.098 2.5	.079 2.0	85,000	122,000					
32222U	4.3307 110	7.8740 200	2.2047 56	2.0866 53	1.8110 46	.098 2.5	.079 2.0	94,500	136,000					
32224U	4.7244 120	8.4646 215	2.4213 61.5	2.2835 58	1.9685 50	.098 2.5	.079 2.0	104,000	153,000					
32226U	5.1181 130	9.0551 230	2.6673 67.75	2.5197 64	2.1260 54	.118 3.0	.098 2.5	119,000	183,000					
32228U	5.5118 140	9.8425 250	2.8248 71.75	2.6772 68	2.2835 58	.118 3.0	.098 2.5	137,000	207,000					
32230U	5.9055 150	10.6299 270	3.0315 77	2.8740 73	2.3622 60	.118 3.0	.098 2.5	157,000	240,000					
32232U	6.2992 160	11.4173 290	3.3071 84	3.1496 80	2.6378 67	.118 3.0	.098 2.5	200,000	320,000					
32234U	6.6929 170	12.2047 310	3.5827 91	3.3858 86	2.7953 71	.157 4.0	.118 3.0	224,000	360,000					
32236U	7.0866 180	12.5984 320	3.5827 91	3.3858 86	2.7953 71	.157 4.0	.118 3.0	231,000	380,000					
32238*	7.4803 190	13.3858 340	3.8189 97	3.6220 92	2.9528 75	.118 3.0	.118 3.0	225,000	375,000					

* These bearings do not adopt subunit size.

TAPERED ROLLER BEARINGS

Units: INCHES
Millimeters



Bearing No.	Bore	O.D.	Overall Width	Cone Width	Cup Width	Fillet Radii		Basic Load Ratings (lbs)	
	<i>d</i>	<i>D</i>	<i>T</i>	<i>B</i>	<i>b</i>	<i>r</i>	<i>r₁</i>	Dynamic <i>C</i>	Static <i>C₀</i>
32240*	7.8740 200	14.1732 360	4.0945 104	3.8583 98	3.2283 82	.118 3.0	.118 3.0	259,000	440,000
4T-32306	1.1811 30	2.8346 72	1.1319 28.75	1.0630 27	.9055 23	.039 1.0	.039 1.0	18,200	20,200
4T-32307	1.3780 35	3.1496 80	1.2894 32.75	1.2205 31	.9843 25	.059 1.5	.059 1.0	22,800	25,800
4T-32308	1.5748 40	3.5433 90	1.3878 35.25	1.2992 33	1.0630 27	.059 1.5	.039 1.0	27,500	33,500
4T-32308C	1.5748 40	3.5433 90	1.3878 35.25	1.2992 33	1.0630 27	.059 1.5	.039 1.0	24,800	31,500
4T-32309	1.7717 45	3.9370 100	1.5059 38.25	1.4173 36	1.1811 30	.059 1.5	.039 1.0	34,500	43,000
4T-32310	1.9685 50	4.3307 110	1.6634 42.25	1.5748 40	1.2992 33	.079 2.0	.059 1.5	41,500	52,000
4T-32311	2.1654 55	4.7244 120	1.7913 45.5	1.6929 43	1.3780 35	.079 2.0	.059 1.5	48,500	62,000
32312U	2.3622 60	5.1181 130	1.9094 48.5	1.8810 46	1.4567 37	.098 2.5	.079 2.0	55,000	70,500
32313U	2.5591 65	5.5118 140	2.0079 51	1.8898 48	1.5354 39	.098 2.5	.079 2.0	61,500	79,000
32314U	2.7559 70	5.9055 150	2.1260 54	2.0079 51	1.6535 42	.098 2.5	.079 2.0	69,500	90,500
32315U	2.9528 75	6.2992 160	2.2835 58	2.1654 55	1.7717 45	.098 2.5	.079 2.0	80,000	105,000
32316U	3.1496 80	6.6929 170	2.4213 61.5	2.2835 58	1.8898 48	.098 2.5	.079 2.0	89,000	118,000
32317U	3.3465 85	7.0866 180	2.5000 63.5	2.3622 60	1.9291 49	.118 3	.098 2.5	90,500	118,000
32318U	3.5433 90	7.4803 190	2.6575 67.5	2.5197 64	2.0866 53	.118 3	.098 2.5	101,000	133,000
32319U	3.7402 95	7.8740 200	2.8150 71.5	2.6378 67	2.1654 55	.118 3	.098 2.5	113,000	151,000
32320U	3.9370 100	8.4646 215	3.0512 77.5	2.8740 73	2.3622 60	.118 3	.098 2.5	128,000	173,000
32321U	4.1339 105	8.8583 225	3.2087 81.5	3.0315 77	2.4803 63	.118 3	.098 2.5	138,000	186,000
32322*	4.3307 110	9.4488 240	3.3268 84.5	3.1496 80	2.5591 65	.098 2.5	.098 2.5	140,000	186,000
32324U	4.7244 120	10.2362 260	3.5630 90.5	3.3858 86	2.7165 69	.118 3	.098 2.5	183,000	255,000
32910XU	1.9685 50	2.8346 72	.5906 15	.5906 15	.4724 12	.024 .6	.024 .6	8,000	12,800
32911XU	2.1654 55	3.1496 80	.6693 17	.6693 17	.5512 14	.024 .6	.024 .6	10,000	16,500
32912XU	2.3622 60	3.3465 85	.6693 17	.6693 17	.5512 14	.024 .6	.024 .6	10,300	17,600
32913XU	2.5591 65	3.5433 90	.6693 17	.6693 17	.5512 14	.024 .6	.024 .6	10,900	19,200
32914XU	2.7559 70	3.9370 100	.7874 20	.7874 20	.6299 16	.024 .6	.024 .6	15,400	24,700
32915XU	2.9528 75	4.1339 105	.7874 20	.7874 20	.6299 16	.024 .6	.024 .6	15,600	25,600
32916XU	3.1496 80	4.3307 110	.7874 20	.7874 20	.6299 16	.024 .6	.024 .6	16,200	27,300
32917XU	3.3465 85	4.7244 120	.9055 23	.9055 23	.7087 18	.039 1.0	.039 1.0	21,100	35,500
32918XU	3.5433 90	4.9213 125	.9055 23	.9055 23	.7087 18	.039 1.0	.039 1.0	21,900	37,500
32919XU	3.7402 95	5.1181 130	.9055 23	.9055 23	.7087 18	.039 1.0	.039 1.0	22,600	40,000
32920XU	3.9370 100	5.5118 140	.9843 25	.9843 25	.7874 20	.039 1.0	.039 1.0	27,200	46,500
32921XU	4.1339 105	5.7087 145	.9843 25	.9843 25	.7874 20	.039 1.0	.039 1.0	28,200	49,500
32922XU	4.3307 110	5.9055 150	.9843 25	.9843 25	.7874 20	.039 1.0	.039 1.0	28,600	51,000
32924XU	4.7244 120	6.4961 165	1.1417 29	1.1417 29	.9055 23	.039 1.0	.039 1.0	36,500	66,000
32926XU	5.1181 130	7.0866 180	1.2598 32	1.2598 32	.9843 25	.059 1.5	.039 1.0	43,500	79,000
32928XU	5.5118 140	7.4803 190	1.2598 32	2.2598 32	.9843 25	.059 1.5	.039 1.0	45,000	84,000
32930XU	5.9055 150	8.2677 210	1.4961 38	1.4961 38	1.1811 30	.079 2.0	.059 1.5	60,000	110,000
32932XU	6.2992 160	8.6614 220	1.4961 38	1.4961 38	1.1811 30	.079 2.0	.059 1.5	62,000	117,000

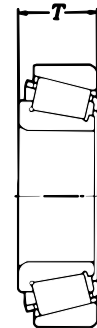
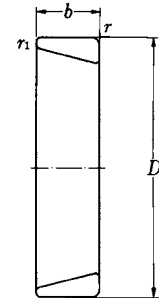
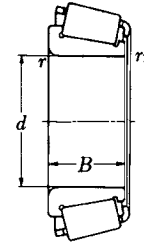

* These bearings do not adopt subunit size.



Units: INCHES
Millimeters

TAPERED ROLLER BEARINGS

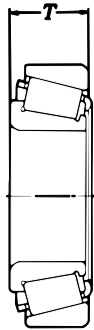
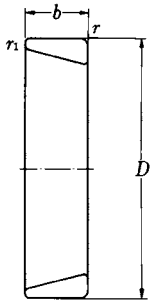
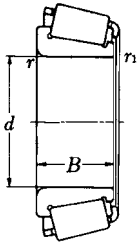

Bearing No.	Bore	O.D.	Overall Width	Cone Width	Cup Width	Fillet Radii		Basic Load Ratings (lbs)	
	<i>d</i>	<i>D</i>	<i>T</i>	<i>B</i>	<i>b</i>	<i>r</i>	<i>r₁</i>	Dynamic <i>C</i>	Static <i>C₀</i>
32934XU	6.6929 170	9.0551 230	1.4961 38	1.4961 38	1.1811 30	.079 2.0	.059 1.5	64,500	125,000
32936XU	7.0866 180	9.8425 250	1.7717 45	1.7717 45	1.3386 34	.079 2.0	.059 1.5	79,000	158,000
32938XU	7.4803 190	10.2362 260	1.7717 45	1.7717 45	1.3386 34	.079 2.0	.059 1.5	79,500	159,000
32940XU	7.8740 200	11.0236 280	2.0079 51	2.0079 51	1.5354 39	.098 2.5	.079 2.0	108,000	201,000
32944XU	8.6614 220	11.8110 300	2.0079 51	2.0079 51	1.5354 39	.098 2.5	.079 2.0	108,000	213,000
32948XU	9.4488 240	12.5984 320	2.0079 51	2.0079 51	1.5354 39	.098 2.5	.079 2.0	110,000	226,000
32952XU	10.2362 260	14.1732 360	2.5000 63.5	2.5000 63.5	1.8898 48	.098 2.5	.079 2.0	159,000	320,000
32956XU	11.0236 280	14.9606 380	2.5000 63.5	2.5000 63.5	1.8898 48	.098 2.5	.079 2.0	163,000	340,000
32960XU	11.8110 300	16.5354 420	2.9921 76	2.9921 76	2.2441 57	.118 3.0	.098 2.5	226,000	470,000
32964XU	12.5984 320	17.3228 440	2.9921 76	2.9921 76	2.2441 57	.118 3.0	.098 2.5	228,000	485,000
32968XU	13.3858 340	18.1102 460	2.9921 76	2.9921 76	2.2441 57	.118 3.0	.098 2.5	235,000	510,000
32972XU	14.1732 360	18.8976 480	2.9921 76	2.9921 76	2.2441 57	.118 3.0	.098 2.5	236,000	525,000
33016U	3.1496 80	4.9213 125	1.4173 36	1.4173 36	1.1614 29.5	.039 1.0	.039 1.0	39,000	64,000
33017U	3.3465 85	5.1181 130	1.4173 36	1.4173 36	1.1614 29.5	.039 1.0	.039 1.0	39,500	66,500
33018U	3.5433 90	5.5118 140	1.5354 39	1.5354 39	1.2795 32.5	.059 1.5	.039 1.0	48,000	80,500
33019U	3.7402 95	5.7087 145	1.5354 39	1.5354 39	1.2795 32.5	.059 1.5	.039 1.0	49,500	84,000
33020U	3.9370 100	5.9055 150	1.5354 39	1.5354 39	1.2795 32.5	.059 1.5	.039 1.0	50,500	87,500
33021U	4.1339 105	6.2992 160	1.6929 43	1.6929 43	1.3386 34	.079 2.0	.059 1.5	55,000	94,500
33022U	4.3307 110	6.6929 170	1.8504 47	1.8504 47	1.4567 37	.079 2.0	.059 1.5	65,000	113,000
4T-33113	2.5591 65	4.3307 110	1.3386 34	1.3386 34	1.0433 26.5	.039 1.0	.039 1.0	32,500	47,500
4T-33208	1.5748 40	3.1496 80	1.2598 32	1.2598 32	.9843 25	.039 1.0	.039 1.0	23,300	29,600
4T-33209	1.7717 45	3.3465 85	1.2598 32	1.2598 32	.9843 25	.039 1.0	.039 1.0	24,100	31,500
4T-33210	1.9685 50	3.5433 90	1.2598 32	1.2598 32	.9646 24.5	.039 1.0	.039 1.0	25,800	35,500
4T-33211	2.1654 55	3.9370 100	1.3780 35	1.3780 35	1.0630 27	.059 1.5	.039 1.0	31,000	42,000
33212U	2.3622 60	4.3307 110	1.4961 38	1.4961 38	1.1417 29	.059 1.5	.039 1.0	37,500	52,500
33213U	2.5591 65	4.7244 120	1.6142 41	1.6142 41	1.2598 32	.059 1.5	.039 1.0	44,000	59,500
33214U	2.7559 70	4.9213 125	1.6142 41	1.6142 41	1.2598 32	.059 1.5	.039 1.0	45,500	63,500
33215U	2.9528 75	5.1181 130	1.6142 41	1.6142 41	1.2205 31	.059 1.5	.039 1.0	46,500	67,000
33216U	3.1496 80	5.5118 140	1.8110 46	1.8110 46	1.3780 35	.079 2.0	.059 1.5	56,500	82,500
33217U	3.3465 85	5.9055 150	1.9291 49	1.9291 49	1.4567 37	.079 2.0	.059 1.5	64,000	94,500

* These bearings do not adopt subunit size.

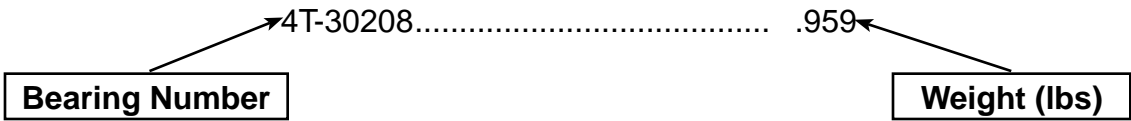

METRIC ISO SERIES TAPERED ROLLER BEARINGS			LBS.
4T-30208.....	.959	30317U.....	11.5
4T-30209.....	1.09	30318DU.....	12.5
4T-30210.....	1.24	30318U.....	13.3
4T-30211.....	1.63	30319.....	14.5
4T-30212.....	2.09	30319DU.....	14.3
4T-30213.....	2.60	30320.....	17.0
4T-30214.....	2.78	30321.....	19.7
4T-30215.....	3.11	30322.....	23.1
30216U.....	3.79	30324.....	29.1
30217U.....	4.72	30326.....	36.8
30218U.....	5.86	30328.....	45.0
30219U.....	6.77	30330.....	54.5
30220U.....	8.33	30332.....	64.4
30221U.....	9.68	30334.....	76.7
30222U.....	11.4	31320XU.....	19.1
30224U.....	13.7	31321XU.....	21.3
30226U.....	16.0	31322XU.....	39.7
30228.....	18.1	31324XU.....	34.0
30230U.....	24.7	31326XU.....	41.9
30232U.....	28.4	31328XU.....	50.7
30234U.....	37.5	31330XU.....	61.1
30236.....	37.9	32016XU.....	2.82
30238U.....	45.9	32017XU.....	2.98
30240.....	54.7	32018XU.....	3.95
4T-30306.....	.899	32019XU.....	4.03
4T-30307.....	1.19	32020XU.....	4.21
4T-30307D.....	1.17	32021XU.....	5.34
4T-30308.....	1.70	32022XU.....	6.77
4T-30308D.....	1.63	32024XU.....	7.17
4T-30309.....	2.23	32026XU.....	10.9
4T-30309D.....	2.11	32028XU.....	11.6
4T-30310.....	2.89	32030XU.....	14.0
4T-30310D.....	2.76	32032XU.....	17.2
4T-30311.....	3.66	32034XU.....	23.1
4T-30311D.....	3.51	32036XU.....	32.0
4T-30312D.....	4.34	32038XU.....	33.3
30312U.....	4.54	32040XU.....	42.5
4T-30313D.....	5.34	32044XU.....	55.1
30313U.....	5.62	32048XU.....	59.1
4T-30314D.....	6.44	32052XU.....	86.9
30314U.....	6.75	32056XU.....	92.2
30315DU.....	7.65	32060XU.....	131
30315U.....	7.87	32064XU.....	138
30316DU.....	9.06	4T-32203R.....	229
30316U.....	9.72	4T-32205R.....	399
30317DU.....	10.7	4T-32208.....	1.23
		4T-32209.....	1.34
		4T-32210.....	1.43
		4T-32211.....	1.93
		32212U.....	2.60
		32213U.....	3.48
		32214U.....	3.70
		32215U.....	3.84
		32216U.....	4.81
		32217U.....	6.06
		32218U.....	7.69
		32219U.....	9.48
		32220U.....	11.3
		32221U.....	13.8
		32222U.....	16.4
		32224U.....	20.0
		32226U.....	24.7
		32228U.....	31.1
		32230U.....	40.1
		32232U.....	51.8
		32234U.....	63.3
		32236U.....	67.7
		32238.....	73.4
		32240.....	96.1
		4T-32306.....	1.29
		4T-32307.....	1.74
		4T-32308.....	2.38
		4T-32308C.....	2.43
		4T-32309.....	3.22
		4T-32310.....	4.23
		4T-32311.....	5.38
		32312U.....	6.66
		32313U.....	8.07
		32314U.....	9.83
		32315U.....	11.8
		32316U.....	14.1
		32317U.....	15.8
		32318U.....	18.9
		32319U.....	22.3
		32320U.....	28.0
		32321U.....	32.0
		32322.....	37.3
		32324U.....	49.4
		32910XU.....	421
		32911XU.....	604
		32912XU.....	648
		32913XU.....	694
		32914XU.....	1.07
		32915XU.....	1.13
		32916XU.....	1.19
		32917XU.....	1.70
		32918XU.....	1.80
		32919XU.....	1.88
		32920XU.....	2.51
		32921XU.....	2.65
		32922XU.....	2.73
		32924XU.....	3.90
		32926XU.....	5.20
		32928XU.....	5.53
		32930XU.....	8.64
		32932XU.....	9.15
		32934XU.....	9.70
		32936XU.....	14.4
		32938XU.....	14.9
		32940XU.....	19.8
		32944XU.....	22.5
		32948XU.....	24.0
		32952XU.....	41.4
		32956XU.....	44.1
		32960XU.....	69.2
		32964XU.....	73.0
		32968XU.....	76.9
		32972XU.....	80.7
		33016U.....	3.53
		33017U.....	3.75
		33018U.....	4.81
		33019U.....	5.00
		33020U.....	5.22
		33021U.....	6.61
		33022U.....	8.38
		4T-33113.....	2.82
		4T-33208.....	1.60
		4T-33209.....	1.73
		4T-33210.....	1.88
		4T-33211.....	2.54
		33212U.....	3.42
		33213U.....	4.37
		33214U.....	4.63
		33215U.....	4.85
		33216U.....	6.44
		33217U.....	7.89

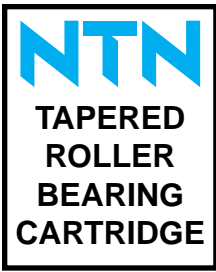

Units: **INCHES**
Millimeters

TAPERED ROLLER BEARINGS FOR WHEEL APPLICATIONS

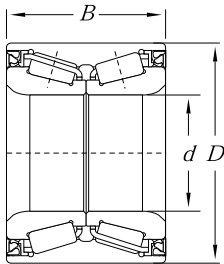
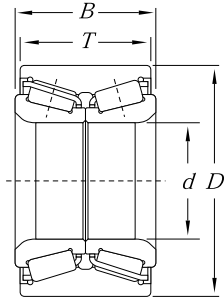

Bearing Number	Bore		O.D.		Width Dimensions		Seal	Basic Load Ratings (lbs)		Weight (lbs)
	d	D	B	T	Dynamic C	Static C_0				
4T-CRI-0574	.98 25	2.05 52	1.46 37	1.46 37	X	60,500	76,500	.79		
4T-CRI-0569	1.06 27	2.05 52	1.73 44	1.69 43		55,000	77,000	.88		
4T-CRI-0685	1.26 32	2.28 58	2.56 65	2.24 57		63,500	93,000	1.63		
4T-CRI-0797	1.34 34	2.67 67.8	1.69 43	1.57 40		88,000	131,000	1.63		
4T-CRI-0760	1.38 35	2.52 64	1.46 37	1.46 37	X	58,500	82,000	1.08		
4T-CRI-0778	1.38 35	2.44 62	2.05 52	1.89 48	X	75,000	113,000	1.37		
4T-CRI-0820	1.50 38	2.52 64	1.26 32	1.14 29		60,000	90,500	.86		
4T-CRI-08A05	1.50 38	2.56 65	2.05 52	1.89 48		60,000	89,500	1.43		
4T-CRI-0849	1.50 38	2.99 76	1.69 43	1.57 40		91,000	139,000	1.39		
4T-CRI-0868	1.54 39	2.68 68	1.46 37	1.46 37	X	62,000	91,500	1.19		
4T-CRI-0826	1.57 40	3.15 80	1.50 38	1.50 38		95,000	137,000	1.94		
4T-CRI-0822	1.65 42	2.83 72	1.50 38	1.50 38	X	75,000	105,000	1.30		
4T-CRI-0823	1.65 42	2.83 72	1.50 38	1.38 35		82,500	127,000	1.32		
4T-CRI-0881	1.65 42	2.83 72	1.50 38	1.38 35		82,500	127,000	1.32		
4T-CRI-08A01	1.65 42	2.83 72	1.50 38	1.38 35		75,000	105,000	1.28		
4T-CRI-08A02	1.65 42	2.83 72	2.05 52	1.89 48		57,000	80,000	1.70		
4T-CRI-0993	1.69 43	2.87 73	1.77 45	1.61 41		75,000	105,000	1.52		
4T-CRI-0966	1.77 45	3.54 90	2.13 54	2.01 51		154,000	223,000	3.42		
4T-CRI-0992	1.81 46	3.03 77	1.77 45	1.61 41		79,500	124,000	1.76		
4T-CRI-0988	1.81 46	3.07 78	1.93 49	1.93 49	X	94,000	148,000	2.07		
4T-CRI-0994	1.81 46	3.15 80	1.69 43	1.57 40		94,000	148,000	2.01		
4T-CRI-1069	1.97 50	3.31 84	2.13 54	2.13 54	X	107,000	173,000	2.38		

**COMPONENT PARTS FOR
TAPERED ROLLER BEARING SETS**



Set Numbers	Cone/Cup
4T-SET 1	4T-LM11749/LM11710
4T-SET 2	4T-LM11949/LM11910
4T-SET 2L	4T-LM11949XJXL/LM11910XL
4T-SET 3	4T-M12649/M12610
4T-SET 4	4T-L44649/L44610
4T-SET 5	4T-LM48548/LM48510
4T-SET 5L	4T-LM48548XJXL/LM48510XL
4T-SET 6	4T-LM67048/LM67010
4T-SET 6L	4T-LM67048XJXL/LM67010XL
4T-SET 7	4T-M201047S/M201011+A *
4T-SET 12	4T-LM12749/LM12710
4T-SET 13	4T-L68149/L68110
4T-SET 14	4T-L44643/L44610
4T-SET 15	4T-L45449/L45410
4T-SET 16	4T-LM12749/LM12711
4T-SET 17	4T-L68149/L68111
4T-SET 18	4T-JL69349/JL69310
4T-SET 19	4T-07100/07196
4T-SET 21	4T-1988/1922
4T-SET 22	4T-JLM506848E/JLM506810DB
4T-SET 23	4T-LM104949E/LM104911DB
4T-SET 24	4T-CR-0659
4T-SET 28	4T-CR-0679PX1
4T-SET 29	4T-LM67045/LM67010
4T-SET 30	4T-CR-0580PX1
4T-SET 31	4T-JL68145/JL68111Z
4T-SET 32	4T-320/28XX1
4T-SET 33	4T-320/32XX1
4T-SET 34	4T-LM12748/LM12710
4T-SET 35	4T-LM501349/LM501310
4T-SET 36	4T-LM603049/LM603012
4T-SET 37	4T-LM603049/LM603011
4T-SET 38	4T-LM104949/LM104911
4T-SET 39	4T-JL26749/JL26710
4T-SET 40	4T-JLM104946/JLM104910Z
4T-SET 42	4T-JLM506849A/JLM506811
4T-SET 47	4T-LM102949/LM102910

* A - Retaining Ring (TKB1001)

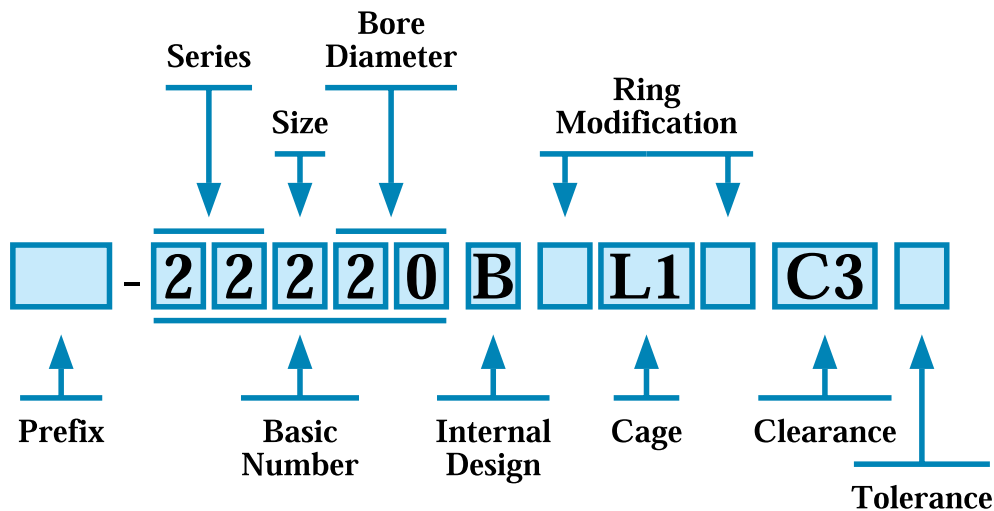
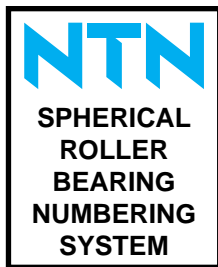

1. PREFIX

- TS2: Heat stabilization for up to 320° F (160° C)
- TS3: Heat stabilization for up to 390° F (200° C)
- TS4: Heat stabilization for up to 480° F (250° C)
- LH: STJ2 Material (Temp 250°C)
- MX: All components phosphate coated

2. SERIES

- 213: Standard series spherical roller bearings
- 222, 223: Standard series spherical roller bearings
- 230, 231, 232, 239: Standard series spherical roller bearings
- 240, 241: Standard series spherical roller bearings
- W: Wide series spherical roller bearing with integral seals

3. INTERNAL DESIGN

- B: One piece ribbed inner ring, asymmetrical rollers and center guided retainer
- C: Plain inner ring, center floating guide ring
- UA: Inner ring without center guide, asymmetrical rollers, and outer ring center-guided retainer (limited thrust capabilities)
- E: High capacity spherical roller bearings

4. CAGE

- No Symbol: Standard cage
- J: Pressed steel cage
- L1: Machined brass cage
- T2: Nylon cage

5. SEALS

- LL: Two integral garter seals with steel backing plates

6. RING MODIFICATION

- D1: Oil groove and holes
- K: 1:12 tapered bore

7. INTERNAL CLEARANCE

- C1: Radial clearance less than C2
- C2: Radial clearance less than normal
- No Suffix: Normal internal clearance
- C3: Radial clearance greater than normal
- C4: Radial clearance greater than C3
- C5: Radial clearance greater than C4
- CSXX: Special radial clearance; XX is mean value in 0.001 mm units

8. TOLERANCE

- No Symbol: Class 0 (equivalent to ABEC 1); standard
- PXn: Special tolerance, from 1 onward
- Vn: Special requirement, from 1 onward
- VS1: Special tolerance for shaker screen bearings (C3 clearance)
- VS2: Special tolerance for shaker screen bearings (C4 clearance)

SPHERICAL ROLLER BEARINGS

Units: INCHES
Millimeters



Bearing No.		Bore	O.D.	Width	Fillet Radius (minimum)	Basic Load Ratings (lbs)	
213	213K	<i>d</i>	<i>D</i>	<i>B</i>	<i>r</i>	Dynamic <i>C</i>	Static <i>C_o</i>
21308C	21308CK	1.5748 40	3.5433 90	.9055 23	.039 1.0	19,800	20,200
21309C	21309CK	1.7717 45	3.9370 100	.9843 25	.039 1.0	23,000	23,800
21310C	21310CK	1.9685 50	4.3307 110	1.0630 27	.059 1.5	26,400	28,500
21311	21311K	2.1654 55	4.7244 120	1.1417 29	.098 2.5	32,500	36,500
21312	21312K	2.3622 60	5.1181 130	1.2205 31	.098 2.5	37,500	43,000
21313	21313K	2.5591 65	5.5118 140	1.2992 33	.098 2.5	43,500	51,000
21314	21314K	2.7559 70	5.9055 150	1.3780 35	.098 2.5	49,500	59,000
21315	21315K	2.9528 75	6.2992 160	1.4567 37	.098 2.5	53,500	64,500
21316	21316K	3.1496 80	6.6929 170	1.5354 39	.098 2.5	58,500	71,000
21317	21317K	3.3465 85	7.0866 180	1.6142 41	.117 3.0	65,000	80,000
21318	21318K	3.5433 90	7.4803 190	1.6929 43	.117 3.0	72,000	90,000
21319	21319K	3.7402 95	7.8740 200	1.7717 45	.117 3.0	75,500	94,500
21320	21320K	3.9370 100	8.4646 215	1.8504 47	.117 3.0	83,000	105,000

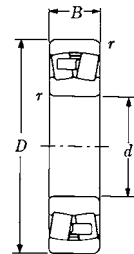

Cylindrical Bore
213

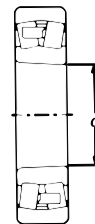

Tapered Bore
213K
Taper 1:12

Note: The *d* dimension for the tapered bore is measured from the side of the bearing with the smallest bore dimension.



Units: INCHES
Millimeters

In this series, machined brass cages are also available. When placing an order for them, put the suffix L1 on the bearing number.

Example: 22211EL1

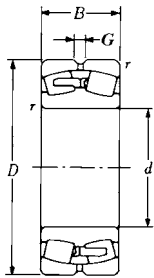

Cylindrical Bore
232

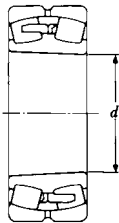

Tapered Bore
232K
Taper 1:12

SPHERICAL ROLLER BEARINGS

Bearing No.		Bore	O.D.	Width	Fillet Radius (minimum)	Oil Groove Width	Basic Load Ratings (lbs)	
222	222K	<i>d</i>	<i>D</i>	<i>B</i>	<i>r</i>	<i>G</i>	Dynamic <i>C</i>	Static <i>C₀</i>
22208CD1	22208CKD1	1.5748 40	3.1496 80	.9055 23	.043 1.1	—	17,800	19,900
22209CD1	22209CKD1	1.7717 45	3.3465 85	.9055 23	.043 1.1	—	18,600	21,400
22210CD1	22210CKD1	1.9685 50	3.5433 90	.9055 23	.043 1.1	—	19,300	23,000
22211ED1	22211EKD1	2.1654 55	3.9370 100	.9843 25	.079 2.0	—	26,460	32,413
22212ED1	22212EKD1	2.3622 60	4.3307 110	1.1024 28	.079 2.0	—	33,736	40,792
22213ED1	22213EKD1	2.5591 65	4.7244 120	1.2205 31	.079 2.0	—	39,690	48,951
22214ED1	22214EKD1	2.7559 70	4.9213 125	1.2205 31	.079 2.0	—	41,233	52,038
22215ED1	22215EKD1	2.9528 75	5.1181 130	1.2205 31	.079 2.0	—	42,777	55,345
22216ED1	22216EKD1	3.1496 80	5.5118 140	1.2992 33	.098 2.5	—	47,848	62,181
22217ED1	22217EKD1	3.3465 85	5.9055 150	1.4173 36	.098 2.5	—	56,448	71,662
22218ED1	22218EKD1	3.5433 90	6.2992 160	1.5748 40	.098 2.5	—	65,709	87,097
22219BD1	22219BKD1	3.7402 95	6.6920 170	1.6929 43	.098 2.5	—	65,500	86,500
22220BD1	22220BKD1	3.9370 100	7.0865 180	1.8110 46	.098 2.5	.31 8	70,000	92,500
22222BD1	22222BKD1	4.3307 110	7.8740 200	2.0866 53	.098 2.5	.39 10	92,500	128,000
22224BD1	22224BKD1	4.7244 120	8.4646 215	2.2835 58	.098 2.5	.39 10	109,000	158,000
22226BD1	22226BKD1	5.1181 130	9.0551 230	2.5197 64	.118 3.0	.39 10	127,000	176,000
22228BD1	22228BKD1	5.5118 140	9.8425 250	2.6772 68	.118 3.0	.39 10	153,000	218,000
22230BD1	22230BKD1	5.9055 150	10.6299 270	2.8740 73	.118 3.0	.47 12	174,000	262,000
22232BD1	22232BKD1	6.2992 160	11.4173 290	3.1496 80	.118 3.0	.47 12	195,000	290,000
22234BD1	22234BKD1	6.6929 170	12.2047 310	3.3858 86	.157 4.0	.47 12	225,000	340,000
22236B	22236BK	7.0866 180	12.5984 320	3.3858 86	.157 4.0	.47 12	233,000	360,000
22238B	22238BK	7.4803 190	13.3858 340	3.6220 92	.157 4.0	.47 12	260,000	410,000
22240B	22240BK	7.8740 200	14.1732 360	3.8583 98	.157 4.0	.47 12	295,000	450,000
22244B	22244BK	8.6614 220	15.7480 400	4.2520 108	.157 4.0	.47 12	350,000	545,000
22248B	22248BK	9.4488 240	17.3228 440	4.7244 120	.157 4.0	.63 16	430,000	680,000
22252B	22252BK	10.2362 260	18.8976 480	5.1181 130	.197 5.0	.63 16	500,000	805,000
22256B	22256BK	11.0236 280	19.6850 500	5.1181 130	.197 5.0	.63 16	520,000	855,000
22260B	22260BK	11.8110 300	21.2598 540	5.5118 140	.197 5.0	.79 20	600,000	975,000
22264B	22264BK	12.5984 320	22.8346 580	5.9055 150	.197 5.0	.79 20	695,000	1,140,000

The suffix D1 means the bearing has lubrication holes and an oil groove. However, for bearing numbers 22236B(K) and over, the suffix D1 is not needed as the lubrication holes and oil groove are standard.

For bearings with a blank G dimension, no lubrication holes and oil groove are provided. These features may be added upon request. (Add suffix D1.)

Note: 'E' type features higher load capacity and high temp. resin cages (40° C to 150° C); EP oil additives could effect cage material.

Note: The d dimension for the tapered bore is measured from the side of the bearing with the smallest bore dimension.

SPHERICAL ROLLER BEARINGS

Units: **INCHES**
Millimeters



Bearing No.		Bore <i>d</i>	O.D. <i>D</i>	Width <i>B</i>	Fillet Radius <i>r</i>	Oil Groove Width <i>G</i>	Basic Load Ratings (lbs)	
223	223K						Dynamic <i>C</i>	Static <i>C₀</i>
22308CD1	22308CKD1	1.5748 40	3.5433 90	1.2992 33	.039 1.0	— —	27,200	28,800
22309CD1	22309CKD1	1.7717 45	3.9370 100	1.4173 36	.059 1.5	— —	33,000	37,500
22310CD1	22310CKD1	1.9685 50	4.3307 110	1.5748 40	.059 1.5	— —	42,000	47,500
22311BD1	22311BKD1	2.1654 55	4.7244 120	1.6929 43	.098 2.5	— —	46,000	52,500
22312BD1	22312BKD1	2.3622 60	5.1181 130	1.8110 46	.098 2.5	— —	53,000	60,500
22313BD1	22313BKD1	2.5591 65	5.5118 140	1.8898 48	.098 2.5	— —	59,500	71,000
22314BD1	22314BKD1	2.7559 70	5.9055 150	2.0079 51	.098 2.5	— —	72,500	85,000
22315BD1	22315BKD1	2.9528 75	6.2992 160	2.1654 55	.098 2.5	— —	74,000	92,000
22316BD1	22316BKD1	3.1496 80	6.6929 170	2.2835 58	.098 2.5	— —	86,000	105,000
22317BD1	22317BKD1	3.3465 85	7.0866 180	2.3622 60	.118 3.0	.31 8	93,500	115,000
22318BD1	22318BKD1	3.5433 90	7.4803 190	2.5197 64	.118 3.0	.39 10	107,000	132,000
22319BD1	22319BKD1	3.7402 95	7.8740 200	2.6378 67	.118 3.0	.39 10	112,000	138,000
22320BD1	22320BKD1	3.9370 100	8.4646 215	2.8740 73	.118 3.0	.39 10	136,000	169,000
22322BD1	22322BKD1	4.3307 110	9.4488 240	3.1496 80	.118 3.0	.39 10	167,000	209,000
22324BD1	22324BKD1	4.7244 120	10.2362 260	3.3858 86	.118 3.0	.47 12	198,000	252,000
22326BD1	22326BKD1	5.1181 130	11.0236 280	3.6614 93	.157 4.0	.47 12	221,000	282,000
22328BD1	22328BKD1	5.5118 140	11.8110 300	4.0157 102	.157 4.0	.47 12	250,000	320,000
22330B	22330BK	5.9055 150	12.5984 320	4.2520 108	.157 4.0	.47 12	281,000	385,000
22332B	22332BK	6.2992 160	13.3858 340	4.4882 114	.157 4.0	.47 12	315,000	440,000
22334B	22334BK	6.6929 170	14.1732 360	4.7244 120	.157 4.0	.47 12	340,000	480,000
22336B	22336BK	7.0866 180	14.9606 380	4.9606 126	.157 4.0	.47 12	385,000	565,000
22338B	22338BK	7.4803 190	15.7480 400	5.1969 132	.197 5.0	.47 12	415,000	615,000
22340B	22340BK	7.8740 200	16.5354 420	5.4331 138	.197 5.0	.63 16	460,000	680,000
22344B	22344BK	8.6614 220	18.1102 460	5.7087 145	.197 5.0	.63 16	530,000	790,000
22348B	22348BK	9.4488 240	19.6850 500	6.1024 155	.197 5.0	.63 16	605,000	910,000
22352B	22352BK	10.2362 260	21.2598 540	6.4961 165	.197 5.0	.79 20	695,000	1,060,000
22356B	22356BK	11.0236 280	22.8346 580	6.8898 175	.236 6.0	.79 20	790,000	1,200,000
22360B	22360BK	11.8110 300	24.4094 620	7.2835 185	.295 7.5	.79 20	805,000	1,210,000

In this series, machined brass cages are also available. When placing an order for them, put the suffix L1 on the bearing number.

Example: 22311BL1

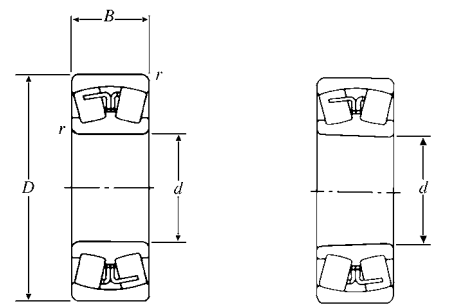

Cylindrical Bore
223B
223C

Tapered Bore
223BK
223CK
Taper 1:12

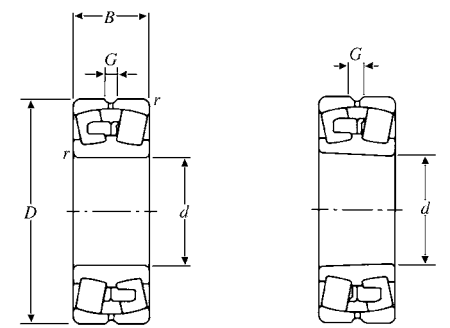

Cylindrical Bore
223B

Tapered Bore
223BK
Taper 1:12

The suffix D1 means the bearing has lubrication holes and an oil groove. However, for bearing numbers 22330B(K) and over, the suffix D1 is not needed as the lubrication holes and oil groove are standard.

For bearings with a blank G dimension, no lubrication holes and oil groove are provided. These features may be added upon request. (Add suffix D1.)

Note: The *d* dimension for the tapered bore is measured from the side of the bearing with the smallest bore dimension.



Units: **INCHES**
Millimeters

In this series, machined brass cages are also available. When placing an order for them, put the suffix L1 on the bearing number.

Example: 23024BL1D1

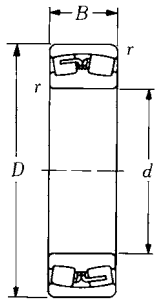

Cylindrical Bore
230

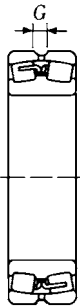

Cylindrical Bore
230

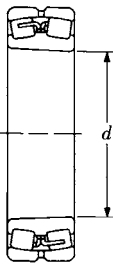

Tapered Bore
230K
Taper 1:12

SPHERICAL ROLLER BEARINGS

Bearing No.		Bore <i>d</i>	O.D. <i>D</i>	Width <i>B</i>	Fillet Radius <i>r</i>	Oil Groove Width <i>G</i>	Basic Load Ratings (lbs)	
230	230K						Dynamic <i>C</i>	Static <i>C₀</i>
23022BD1	23022BKD1	4.3307 110	6.6929 170	1.7717 45	.098 2.5	.31 8	63,500	102,000
23024BD1	23024BKD1	4.7244 120	7.0866 180	1.8110 46	.098 2.5	.31 8	66,500	111,000
23026BD1	23026BKD1	5.1181 130	7.8740 200	2.0472 52	.098 2.5	.31 8	84,500	139,000
23028BD1	23028BKD1	5.5118 140	8.2677 210	2.0866 53	.098 2.5	.31 8	90,500	156,000
23030BD1	23030BKD1	5.9055 150	8.8583 225	2.2047 56	.098 2.5	.31 8	100,000	174,000
23032BD1	23032BKD1	6.2992 160	9.4488 240	2.3622 60	.098 2.5	.31 8	114,000	199,000
23034BD1	23034BKD1	6.6929 170	10.2362 260	2.6378 67	.098 2.5	.39 10	141,000	242,000
23036BD1	23036BKD1	7.0866 180	11.0236 280	2.9134 74	.098 2.5	.39 10	166,000	291,000
23038BD1	23038BKD1	7.4803 190	11.4173 290	2.9528 75	.098 2.5	.39 10	170,000	305,000
23040BD1	23040BKD1	7.8740 200	12.2047 310	3.2283 82	.098 2.5	.39 10	205,000	365,000
23044B	23044BK	8.6614 220	13.3858 340	3.5433 90	.118 3.0	.47 12	238,000	430,000
23048B	23048BK	9.4488 240	14.1732 360	3.6220 92	.118 3.0	.47 12	255,000	480,000
23052B	23052BK	10.2362 260	15.7480 400	4.0945 104	.157 4.0	.47 12	320,000	590,000
23056B	23056BK	11.0236 280	16.5354 420	4.1732 106	.157 4.0	.47 12	340,000	655,000
23060B	23060BK	11.8110 300	18.1102 460	4.6457 118	.157 4.0	.47 12	425,000	800,000
23064B	23064BK	12.5984 320	18.8976 480	4.7638 121	.157 4.0	.47 12	440,000	870,000
23068B	23068BK	13.3858 340	20.4724 520	5.2362 133	.197 5.0	.63 16	505,000	990,000
23072B	23072BK	14.1732 360	21.2598 540	5.2756 134	.197 5.0	.63 16	535,000	1,060,000
23076B	23076BK	14.9606 380	22.0472 560	5.3150 135	.197 5.0	.63 16	550,000	1,120,000
23080B	23080BK	15.7480 400	23.6220 600	5.8268 148	.197 5.0	.63 16	655,000	1,320,000
23084B	23084BK	16.5354 420	24.4094 620	5.9055 150	.197 5.0	.63 16	680,000	1,400,000
23088B	23088BK	17.3228 440	25.5906 650	6.1811 157	.236 6.0	.79 20	735,000	1,540,000
23092B	23092BK	18.1102 460	26.7717 680	6.4173 163	.236 6.0	.79 20	805,000	1,680,000
23096B	23096BK	18.8976 480	27.5591 700	6.4961 165	.236 6.0	.79 20	835,000	1,770,000
230/500B	230/500BK	19.6850 500	28.3465 720	6.5748 167	.236 6.0	.79 20	860,000	1,870,000
230/530B	230/530BK	20.8661 530	30.7087 780	7.2835 185	.236 6.0	.79 20	985,000	2,110,000
230/560B	230/560BK	22.0472 560	32.2835 820	7.6772 195	.236 6.0	.79 20	1,080,000	2,360,000
230/600B	230/600BK	23.6220 600	34.2520 870	7.8740 200	.236 6.0	.79 20	1,160,000	2,640,000
230/630B	230/630BK	24.8031 630	36.2205 920	8.3465 212	.295 7.5	.79 20	1,320,000	2,920,000
230/670B	230/670BK	26.3780 670	38.5827 980	9.0551 230	.295 7.5	.79 20	1,470,000	3,300,000
230/710B	230/710BK	27.9528 710	40.5512 1030	9.2913 236	.295 7.5	.94 24	1,610,000	3,650,000
230/750B	230/750BK	29.5276 750	42.9134 1090	9.8425 250	.295 7.5	.94 24	1,840,000	4,100,000

The suffix D1 means the bearing has lubrication holes and an oil groove. However, for bearing numbers 23044B(K) and over, the suffix D1 is not needed as the lubrication holes and the oil groove are standard.

Note: The *d* dimension for the tapered bore is measured from the side of the bearing with the smallest bore dimension.

SPHERICAL ROLLER BEARINGS

Units: INCHES
Millimeters



Bearing No.		Bore <i>d</i>	O.D. <i>D</i>	Width <i>B</i>	Fillet Radius <i>r</i>	Oil Groove Width <i>G</i>	Basic Load Ratings (lbs)	
231	231K						Dynamic <i>C</i>	Static <i>C₀</i>
23122BD1	23122BKD1	4.3307 110	7.0866 180	2.2047 56	.098 2.5	.31 8	83,000	131,000
23124BD1	23124BKD1	4.7244 120	7.8740 200	2.4409 62	.098 2.5	.39 10	102,000	158,000
23126BD1	23126BKD1	5.1181 130	8.2677 210	2.5197 64	.098 2.5	.39 10	111,000	179,000
23128BD1	23128BKD1	5.5118 140	8.8583 225	2.6772 68	.098 2.5	.39 10	121,000	201,000
23130BD1	23130BKD1	5.9055 150	9.8425 250	3.1496 80	.098 2.5	.39 10	165,000	268,000
23132BD1	23132BKD1	6.2992 160	10.6299 270	3.3858 86	.098 2.5	.47 12	189,000	310,000
23134BD1	23134BKD1	6.6929 170	11.0236 280	3.4646 88	.098 2.5	.47 12	199,000	335,000
23136BD1	23136BKD1	7.0866 180	11.8110 300	3.7795 96	.118 3.0	.47 12	232,000	390,000
23138B	23138BK	7.4803 190	12.5984 320	4.0945 104	.118 3.0	.47 12	268,000	455,000
23140B	23140BK	7.8740 200	13.3858 340	4.4094 112	.118 3.0	.47 12	305,000	510,000
23144B	23144BK	8.6614 220	14.5669 370	4.7244 120	.157 4.0	.47 12	350,000	610,000
23148B	23148BK	9.4488 240	15.7480 400	5.0394 128	.157 4.0	.47 12	390,000	690,000
23152B	23152BK	10.2362 260	17.3228 440	5.6693 144	.157 4.0	.63 16	470,000	845,000
23156B	23156BK	11.0236 280	18.1102 460	5.7480 146	.197 5.0	.63 16	505,000	930,000
23160B	23160BK	11.8110 300	19.6850 500	6.2992 160	.197 5.0	.63 16	605,000	1,090,000
23164B	23164BK	12.5984 320	21.2598 540	6.9291 176	.197 5.0	.79 20	700,000	1,300,000
23168B	23168BK	13.3858 340	22.8346 580	7.4803 190	.197 5.0	.79 20	810,000	1,480,000
23172B	23172BK	14.1732 360	23.6220 600	7.5591 192	.197 5.0	.79 20	845,000	1,580,000
23176B	23176BK	14.9606 380	24.4094 620	7.6378 194	.197 5.0	.79 20	880,000	1,690,000
23180B	23180BK	15.7480 400	25.5906 650	7.8740 200	.236 6.0	.94 24	940,000	1,810,000
23184B	23184BK	16.5354 420	27.5591 700	8.8189 224	.236 6.0	.94 24	1,150,000	2,200,000
23188B	23188BK	17.3228 440	28.3465 720	8.8976 226	.236 6.0	.94 24	1,170,000	2,260,000
23192B	23192BK	18.1102 460	28.9212 760	9.4488 240	.295 7.5	.94 24	1,290,000	2,560,000
23196B	23196BK	18.8976 480	31.1024 790	9.7638 248	.295 7.5	.94 24	1,410,000	2,810,000
231/500B	231/500BK	19.6850 500	32.6772 830	10.3937 264	.295 7.5	.94 24	1,540,000	3,050,000
231/530B	231/530BK	20.8661 530	34.2520 870	10.7087 272	.295 7.5	.94 24	1,570,000	3,200,000
231/560B	231/560BK	22.0472 560	36.2205 920	11.0236 280	.295 7.5	.94 24	1,720,000	3,500,000
231/600B	231/600BK	23.6220 600	38.5827 980	11.8110 300	.295 7.5	.94 24	2,030,000	4,150,000
231/630B	231/630BK	24.8031 630	40.5512 1030	12.4016 315	.295 7.5	.94 24	2,150,000	4,450,000
231/670B	231/670BK	26.3780 670	42.9134 1090	13.2283 336	.295 7.5	.94 24	2,530,000	5,300,000
231/710B	231/710BK	27.9528 710	45.2756 1150	13.5827 345	.374 9.5	.94 24	2,620,000	5,600,000

In this series, machined brass cages are also available. When placing an order for them, put the suffix L1 on the bearing number.

Example: 23124BL1D1

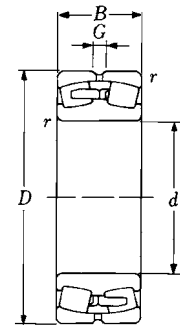

Cylindrical Bore
231

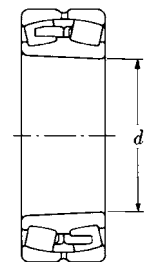

Tapered Bore
231K
Taper 1:12

The suffix D1 means the bearing has lubrication holes and an oil groove. However, for bearing numbers 23138B(K) and over, the suffix D1 is not needed as the lubrication holes and oil groove are standard.

Note: The *d* dimension for the tapered bore is measured from the side of the bearing with the smallest bore dimension.



Units: INCHES
Millimeters

Use Suffix L1 for brass cages.
Example: 23218BL1

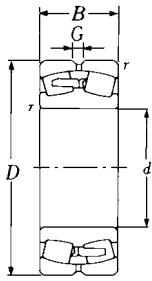

Cylindrical Bore
232

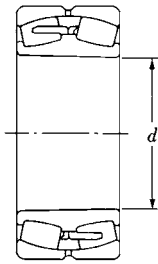

Tapered Bore
232K
Taper 1:12

SPHERICAL ROLLER BEARINGS

Bearing No.		Bore	O.D.	Width	Fillet Radius	Oil Groove Width	Basic Load Ratings (lbs)	
232	232K	<i>d</i>	<i>D</i>	<i>B</i>	<i>r</i>	<i>G</i>	Dynamic <i>C</i>	Static <i>C₀</i>
23218BD1	23218BKD1	3.5433 90	6.2992 160	2.0630 52.4	.039 1.0	—	71,500	103,000
23220BD1	23220BKD1	3.9370 100	7.0866 180	3.3740 60.3	.083 2.1	—	91,000	130,000
23222BD1	23222BKD1	4.3307 110	7.8740 200	2.7480 69.8	.079 2.0	.39 10	115,000	171,000
23224BD1	23224BKD1	4.7244 120	8.4646 215	2.9921 76	.079 2.0	.39 10	132,000	198,000
23226BD1	23226BKD1	5.1181 130	9.0551 230	3.1496 80	.098 2.5	.39 10	154,000	239,000
23228BD1	23228BKD1	5.5118 140	9.8425 250	3.4646 88	.098 2.5	.39 10	181,000	285,000
23230BD1	23230BKD1	5.9055 150	10.6299 270	3.7705 96	.098 2.5	.47 12	210,000	330,000
23232BD1	23232BKD1	6.2992 160	11.4173 290	4.0945 104	.098 2.5	.47 12	237,000	375,000
23234BD1	23234BKD1	6.6929 170	12.2047 310	4.3307 110	.118 3.0	.47 12	264,000	440,000
23236B	23236BK	7.0866 180	12.5984 320	4.4094 112	.118 3.0	.47 12	284,000	465,000
23238B	23238BK	7.4803 190	13.3858 340	4.7244 120	.118 3.0	.47 12	320,000	530,000
23240B	23240BK	7.8740 200	14.1732 360	5.0394 128	.118 3.0	.47 12	365,000	595,000
23244B	23244BK	8.6614 220	15.7480 400	5.6693 144	.118 3.0	.47 12	440,000	730,000
23248B	23248BK	9.4488 240	17.3228 440	6.2992 160	.118 3.0	.63 16	535,000	900,000
23252B	23252BK	10.2362 260	18.8976 480	6.8504 174	.157 4.0	.63 16	620,000	1,060,000
23256B	23256BK	11.0236 280	19.6850 500	6.9291 176	.157 4.0	.63 16	660,000	1,160,000
23260B	23260BK	11.8110 300	21.2598 540	7.5591 192	.157 4.0	.79 20	775,000	1,350,000
23264B	23264BK	12.5984 320	22.8346 580	8.1890 208	.157 4.0	.79 20	890,000	1,560,000
23268B	23268BK	13.3858 340	24.4094 620	8.8189 224	.197 5.0	.79 20	990,000	1,760,000
23272B	23272BK	14.1732 360	25.5906 650	9.1339 232	.197 5.0	.94 24	1,090,000	1,950,000
23276B	23276BK	14.9606 380	26.7717 680	9.4488 240	.197 5.0	.94 24	1,170,000	2,170,000
23280B	23280BK	15.7480 400	28.3465 720	10.0787 256	.197 5.0	.94 24	1,330,000	2,420,000
23284B	23284BK	16.5354 420	29.9213 760	10.7087 272	.295 7.5	.94 24	1,450,000	2,660,000
23288B	23288BK	17.3228 440	31.1024 790	11.0236 280	.295 7.5	.94 24	1,530,000	2,850,000
23292B	23292BK	18.1102 460	32.6772 830	11.6535 296	.295 7.5	.94 24	1,730,000	3,200,000
23296B	23296BK	18.8976 480	34.2520 870	12.2047 310	.295 7.5	.94 24	1,880,000	3,550,000
232/500B	232/500BK	19.6850 500	36.2205 920	13.2283 336	.295 7.5	.94 24	2,120,000	4,000,000
232/530B	232/530BK	20.8661 530	38.5826 980	13.9764 355	.295 7.5	1.65 42	2,330,000	4,450,000
232/560B	232/560BK	22.0472 560	40.5511 1,030	14.3701 365	.374 9.5	1.65 42	2,490,000	4,750,000
232/600B	232/600BK	23.6220 600	42.9133 1,090	15.2756 388	.374 9.5	1.65 42	2,740,000	5,350,000
232/630B	232/630BK	24.8031 630	45.2755 1,150	16.2204 412	.374 9.5	1.65 42	3,100,000	6,050,000
232/670B	232/670BK	26.3779 670	48.0314 1,220	17.2441 438	.374 9.5	1.65 42	3,600,000	7,150,000
232/710B	232/710BK	27.9527 710	50.3936 1,280	17.7165 450	.374 9.5	1.65 42	3,650,000	7,300,000
232/750B	232/750BK	29.5275 750	53.5432 1,360	18.7008 475	.374 9.5	1.65 42	4,100,000	8,250,000

The suffix D1 means the bearing has lubrication holes and an oil groove. However, for bearing numbers 23236B(K) and over, the suffix D1 is not needed as the lubrication holes and oil groove are standard.

Note: The *d* dimension for the tapered bore is measured from the side of the bearing with the smallest bore dimension.

SPHERICAL ROLLER BEARINGS

Bearing No.		Bore	O.D.	Width	Fillet Radius	Oil Groove Width	Basic Load Ratings (lbs)	
239	239K	<i>d</i>	<i>D</i>	<i>B</i>	<i>r</i>	<i>G</i>	Dynamic <i>C</i>	Static <i>C_o</i>
23926D1	23926KD1	5.1181 130	7.0866 180	1.4567 37	.079 2.0	.28 7	48,000	85,000
23932D1	23932KD1	6.2992 160	8.6614 220	1.7717 45	.098 2.5	.31 8	72,500	138,000
23934D1	23934KD1	6.6929 170	9.0551 230	1.7717 45	.098 2.5	.31 8	74,500	146,000
23936D1	23936KD1	7.0866 180	9.8425 250	2.0472 52	.098 2.5	.31 8	99,500	188,000
23938D1	23938KD1	7.4803 190	10.2362 260	2.0472 52	.098 2.5	.39 10	103,000	200,000
23940D1	23940KD1	7.8740 200	11.0236 280	2.3622 60	.098 2.5	.39 10	123,000	247,000
23944D1	23944KD1	8.6614 220	11.8110 300	2.3622 60	.098 2.5	.39 10	127,000	263,000
23948	23948K	9.4488 240	12.5984 320	2.3622 60	.098 2.5	.47 12	127,000	267,000
23952	23952K	10.2362 260	14.1732 360	2.9528 75	.098 2.5	.47 12	171,000	355,000
23956	23956K	11.0236 280	14.9606 380	2.9528 75	.098 2.5	.47 12	187,000	395,000
23960	23960K	11.8110 300	16.5354 420	3.5433 90	.118 3.0	.47 12	249,000	520,000
23964	23964K	12.5984 320	17.3228 440	3.5433 90	.118 3.0	.47 12	257,000	555,000
23968	23968K	13.3858 340	18.1102 460	3.5433 90	.118 3.0	.47 12	274,000	595,000
23972	23972K	14.1732 360	18.8976 480	3.5433 90	.118 3.0	.47 12	298,000	660,000
23976	23976K	14.9606 380	20.4724 520	4.1732 106	.157 4.0	.63 16	350,000	795,000
23980	23980K	15.7480 400	21.2598 540	4.1732 106	.157 4.0	.63 16	355,000	820,000
23984	23984K	16.5354 420	22.0472 560	4.1732 106	.157 4.0	.63 16	365,000	865,000
23988	23988K	17.3228 440	23.6220 600	4.6457 118	.157 4.0	.63 16	455,000	1,050,000
23992	23992K	18.1102 460	24.4094 620	4.6457 118	.157 4.0	.63 16	470,000	1,110,000
23996	23996K	18.8976 480	25.5906 650	5.0394 128	.197 5.0	.79 20	525,000	1,240,000
239/500	239/500K	19.6850 500	26.3780 670	5.0394 128	.197 5.0	.79 20	535,000	1,260,000
239/530	239/530K	20.8661 530	27.5928 710	5.3543 136	.197 5.0	.79 20	595,000	1,450,000
239/560	239/560K	22.0472 560	29.5276 750	5.5118 140	.197 5.0	.79 20	635,000	1,500,000
239/600	239/600K	23.6220 600	31.4961 800	5.9055 150	.197 5.0	.79 20	710,000	1,750,000
239/630	239/630K	24.8031 630	33.4646 850	6.4961 165	.236 6.0	.79 20	830,000	2,080,000
239/670	239/670K	26.3780 670	35.4331 900	6.6929 170	.236 6.0	.79 20	925,000	2,330,000
239/710	239/710K	27.9528 710	37.4016 950	7.0866 180	.236 6.0	.79 20	995,000	2,580,000
239/750	239/750K	29.5276 750	39.3701 1000	7.2835 185	.236 6.0	.79 20	1,130,000	2,930,000
239/800	239/800K	31.4961 800	41.7323 1060	7.6772 195	.236 6.0	.94 24	1,220,000	3,100,000
239/850	239/850K	33.4646 850	44.0945 1120	7.8740 200	.236 6.0	.94 24	1,310,000	3,400,000
239/900	239/900K	35.4331 900	46.4567 1180	8.1102 206	.236 6.0	.94 24	1,490,000	3,900,000

Units: INCHES
Millimeters



In this series, machined brass cages are also available. When placing an order for them, put the suffix L1 on the bearing number.

Example: 23932L1D1

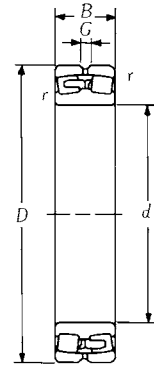

Cylindrical Bore
239

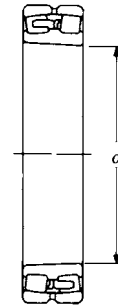

Tapered Bore
239K
Taper 1:12

The suffix D1 means the bearing has lubrication holes and an oil groove. However, for bearing numbers 23948(K) and over, the suffix D1 is not needed as the lubrication holes and oil groove are standard.

Note: The *d* dimension for the tapered bore is measured from the side of the bearing with the smallest bore dimension.



Units: **INCHES**
Millimeters

Bearing Numbers 24048B(K30) and under have machined brass cages. Machined brass cage are also available for bearing numbers 24052B(K30) and over. When placing an order for them, put the suffix L1 on the bearing number.

Example: 24052BL1

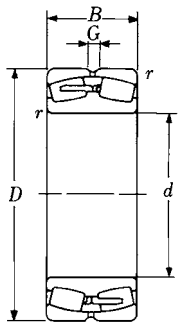

Cylindrical Bore
240

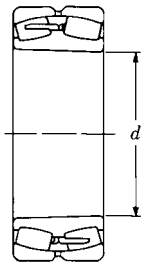

Tapered Bore
240K30
Taper 1:30

SPHERICAL ROLLER BEARINGS

Bearing No.		Bore <i>d</i>	O.D. <i>D</i>	Width <i>B</i>	Fillet Radius <i>r</i>	Oil Groove Width <i>G</i>	Basic Load Ratings (lbs)	
240	240K30						Dynamic <i>C</i>	Static <i>C₀</i>
24024BD1	24024BK30D1	4.7244 120	7.0866 180	2.3622 60	.098 2.5	.31 8	87,000	151,000
24026BD1	24026BK30D1	5.1181 130	7.8740 200	2.7165 69	.098 2.5	.31 8	114,000	201,000
24028BD1	24028BK30D1	5.5118 140	8.2677 210	2.7165 69	.098 2.5	.31 8	115,000	213,000
24030BD1	24030BK30D1	5.9055 150	8.8583 225	2.9528 75	.098 2.5	.31 8	131,000	238,000
24032BD1	24032BK30D1	6.2992 160	9.4488 240	3.1496 80	.098 2.5	.31 8	146,000	269,000
24034BD1	24034BK30D1	6.6929 170	10.2362 260	3.5433 90	.098 2.5	.39 10	180,000	330,000
24036BD1	24036BK30D1	7.0866 180	11.0236 280	3.9370 100	.098 2.5	.39 10	219,000	405,000
24038BD1	24038BK30D1	7.4803 190	11.4173 290	3.9370 100	.098 2.5	.39 10	224,000	415,000
24040BD1	24040BK30D1	7.8740 200	12.2047 310	4.2913 109	.098 2.5	.39 10	264,000	490,000
24044B	24044BK30	8.6614 220	13.3858 340	4.6457 118	.118 3.0	.47 12	305,000	580,000
24048B	24048BK30	9.4488 240	14.1732 360	4.6457 118	.118 3.0	.47 12	320,000	630,000
24052B	24052BK30	10.2362 260	15.7480 400	5.5118 140	.118 3.0	.47 12	410,000	800,000
24056B	24056BK30	11.0236 280	16.5354 420	5.5118 140	.118 3.0	.47 12	440,000	890,000
24060B	24060BK30	11.8110 300	18.1102 460	6.2992 160	.118 3.0	.47 12	550,000	1,120,000
24064B	24064BK30	12.5984 320	18.8976 480	6.2992 160	.118 3.0	.47 12	565,000	1,170,000
24068B	24068BK30	13.3858 340	20.4724 520	7.0866 180	.157 4.0	.63 16	675,000	1,390,000
24072B	24072BK30	14.1732 360	21.2598 540	7.0866 180	.157 4.0	.63 16	690,000	1,450,000
24076B	24076BK30	14.9606 380	22.0472 560	7.0866 180	.157 4.0	.63 16	715,000	1,560,000
24080B	24080BK30	15.7480 400	23.6220 600	7.8740 200	.157 4.0	.63 16	860,000	1,890,000
24084B	24084BK30	16.5354 420	24.4094 620	7.8740 200	.197 5.0	.63 16	870,000	1,900,000
24088B	24088BK30	17.3228 440	25.5906 650	8.3464 212	.236 6.0	.79 20	965,000	2,120,000
24092B	24092BK30	18.1102 460	26.7717 680	8.5827 218	.236 6.0	.79 20	1,030,000	2,280,000
24096B	24096BK30	18.8976 480	27.5591 700	8.5827 218	.236 6.0	.79 20	1,060,000	2,400,000
240/500B	240/500BK30	19.6850 500	28.3465 720	8.5827 218	.236 6.0	.79 20	1,090,000	2,500,000

The suffix D1 means the bearing has lubrication holes and an oil groove. However, for bearing numbers 24044B(K) and over, the suffix D1 is not needed as the lubrication holes and oil groove are standard.

Note: The *d* dimension for the tapered bore is measured from the side of the bearing with the smallest bore dimension.

SPHERICAL ROLLER BEARINGS

Bearing No.		Bore	O.D.	Width	Fillet Radius	Oil Groove Width	Basic Load Ratings (lbs)	
241	241K30	<i>d</i>	<i>D</i>	<i>B</i>	<i>r</i>	<i>G</i>	Dynamic <i>C</i>	Static <i>C_o</i>
24122BD1	24122BK30D1	4.3307 110	7.0866 180	2.7165 69	.098 2.5	.31 8	101,000	170,000
24124BD1	24124BK30D1	4.7244 120	7.8740 200	3.1496 80	.098 2.5	.31 8	129,000	213,000
24126BD1	24126BK30D1	5.1181 130	8.2677 210	3.1496 80	.098 2.5	.31 8	132,000	224,000
24128BD1	24128BK30D1	5.5118 140	8.8583 225	3.3465 85	.098 2.5	.31 8	151,000	257,000
24130BD1	24130BK30D1	5.9055 150	9.8425 250	3.9370 100	.098 2.5	.31 8	201,000	350,000
24132BD1	24132BK30D1	6.2992 160	10.6299 270	4.2913 109	.098 2.5	.39 10	234,000	400,000
24134BD1	24134BK30D1	6.6929 170	11.0236 280	4.2913 109	.098 2.5	.39 10	242,000	420,000
24136BD1	24136BK30D1	7.0866 180	11.8110 300	4.6457 118	.118 3.0	.39 10	280,000	495,000
24138B	24138BK30	7.4803 190	12.5984 320	5.0394 128	.118 3.0	.47 12	320,000	555,000
24140B	24140BK30	7.8740 200	13.3858 340	5.5118 140	.118 3.0	.47 12	365,000	650,000
24144B	24144BK30	8.6614 220	14.5669 370	5.9055 150	.157 4.0	.47 12	425,000	760,000
24148B	24148BK30	9.4488 240	15.7480 400	6.2992 160	.157 4.0	.47 12	475,000	860,000
24152B	24152BK30	10.2362 260	17.3228 440	7.0866 180	.157 4.0	.47 12	555,000	1,010,000
24156B	24156BK30	11.0236 280	18.1102 460	7.0866 180	.197 5.0	.47 12	605,000	1,150,000
24160B	24160BK30	11.8110 300	19.6850 500	7.8740 200	.197 5.0	.47 12	745,000	1,430,000
24164B	24164BK30	12.5984 320	21.2598 540	8.5827 218	.197 5.0	.63 16	865,000	1,640,000
24168B	24168BK30	13.3858 340	22.8346 580	9.5669 243	.197 5.0	.63 16	1,030,000	2,010,000
24172B	24172BK30	14.1732 360	23.6220 600	9.5669 243	.197 5.0	.63 16	1,040,000	2,090,000
24176B	24176BK30	14.9606 380	24.4094 620	9.5669 243	.197 5.0	.63 16	1,070,000	2,130,000
24180B	24180BK30	15.7480 400	25.5906 650	9.8425 250	.236 6.0	.79 20	1,140,000	2,330,000
24184B	24184BK30	16.5354 420	27.5591 700	11.0236 280	.236 6.0	.79 20	1,380,000	2,740,000
24188B	24188BK30	17.3228 440	28.3465 720	11.0236 280	.236 6.0	.79 20	1,450,000	2,940,000
24192B	24192BK30	18.1102 460	29.9213 760	11.8110 300	.295 7.5	.79 20	1,600,000	3,250,000
24196B	24196BK30	18.8976 480	31.1024 790	12.1260 308	.295 7.5	.79 20	1,690,000	3,500,000
241/500B	241/500BK30	19.6850 500	32.6772 830	12.7953 325	.295 7.5	.79 20	1,830,000	3,800,000

Units: INCHES
Millimeters



Bearing numbers 24144B(K30) and under have machined brass cages. Machined brass cages are also available for bearing numbers 24148B(K30) and over. When placing an order for them, put the suffix L1 on the bearing number.

Example: 24148BL1

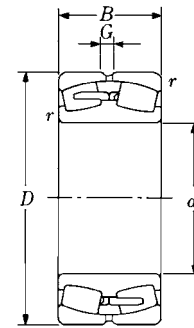

Cylindrical Bore
241

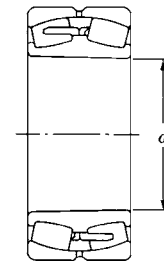

Tapered Bore
241K30
Taper 1:30

The suffix D1 means the bearing has lubrication holes and an oil groove. However, for bearing numbers 24138B(K30) and over, the suffix D1 is not needed as the lubrication holes and oil groove are standard.

Note: The *d* dimension for the tapered bore is measured from the side of the bearing with the smallest bore dimension.

NTN
SERIES
223 UAVS1
SHAKER
SCREEN
BEARINGS

Units: **INCHES**
 Millimeters

SPHERICAL ROLLER BEARINGS

Bearing No.	Bore d	O.D. D	Width B	Fillet Radius r	Oil Groove Width G	Basic Load Ratings (lbs)	
						Dynamic C	Static C_o
22314UAVS1	2.7559 70	5.9055 150	2.0079 51	.098 2.5	.31 8	77,000	92,500
22315UAVS1	2.9528 75	6.2992 160	2.1654 55	.098 2.5	.31 8	86,500	112,000
22316UAVS1	3.1496 80	6.6929 170	2.2835 58	.098 2.5	.31 8	94,500	118,000
22317UAVS1	3.3465 85	7.0866 180	2.3622 60	.118 3.0	.31 8	102,000	128,000
22318UAVS1	3.5433 90	7.4803 190	2.5197 64	.118 3.0	.39 10	116,000	146,000
22319UAVS1	3.7402 95	7.8740 200	2.6378 67	.118 3.0	.39 10	127,000	162,000
22320UAVS1	3.9370 100	8.4646 215	2.8740 73	.118 3.0	.39 10	151,000	194,000
22322UAVS1	4.3307 110	9.4488 240	3.1496 80	.118 3.0	.39 10	188,000	244,000
22324UAVS1	4.7244 120	10.2362 260	3.3858 86	.118 3.0	.47 12	212,000	276,000
22326UAVS1	5.1181 130	11.0236 280	3.6614 93	.157 4.0	.47 12	246,000	325,000
22328UAVS1	5.5118 140	11.8110 300	4.0157 102	.157 4.0	.47 12	287,000	385,000
22330UAVS1	5.9055 150	12.5984 320	4.2520 108	.157 4.0	.47 12	320,000	460,000
22332UAVS1	6.2992 160	13.3858 340	4.4882 114	.157 4.0	.47 12	345,000	495,000
22334UAVS1	6.6929 170	14.1732 360	4.7244 120	.157 4.0	.47 12	385,000	565,000
22336UAVS1	7.0866 180	14.9606 380	4.9606 126	.157 4.0	.47 12	435,000	655,000
22338UAVS1	7.4803 190	15.7480 400	5.1969 132	.197 5.0	.47 12	470,000	720,000
22340UAVS1	7.8740 200	16.5354 420	5.4331 138	.197 5.0	.63 16	500,000	765,000

The cage is made of machined brass.

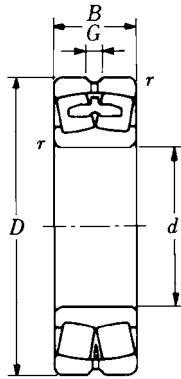

223

The suffix VS1 means the bearing has controlled O.D., bore and radial clearance for shaker screen application.

Note: Lubrication holes and oil groove provided as standard; suffix D1 not needed.

SPHERICAL ROLLER BEARINGS

Units: **Millimeters**
INCHES



Bearing No. MX-W222K	Bore <i>d</i>	O.D. <i>D</i>	Width <i>B</i>	Fillet Radius <i>r</i>	Oil Groove Width <i>G</i>	Basic Load Ratings (lbs)	
						Dynamic <i>C</i>	Static <i>C</i>
MX-W22211BLLKC3	55 2.1654	100 3.9370	40 1.5748	0.60 0.024	6 0.2362	21,000	24,700
MX-W22213BLLKC3	65 2.5591	120 4.7244	46.5 1.8307	0.60 0.024	6 0.2362	32,000	40,000
MX-W22215BLLKC3	75 2.9528	130 5.1181	46.5 1.8307	0.60 0.024	8 0.3150	37,500	50,000
MX-W22217BLLKC3	85 3.3465	150 5.9055	51.5 2.0276	0.60 0.024	8 0.3150	46,500	61,000
MX-W22220BLLKC3	100 3.9370	180 7.0866	64.5 2.5394	1.0 0.039	8 0.3150	69,500	92,000
MX-W22222BLLKC3	110 4.3307	200 7.8740	71 2.7953	1.0 0.039	8 0.3150	92,000	128,000
MX-W22224BLLKC3	120 4.7244	215 8.4646	76 2.9921	1.0 0.039	10 0.3937	109,000	157,000
MX-W22226BLLKC3	130 5.1181	230 9.0551	84 3.3071	1.0 0.039	10 0.3937	127,000	176,000
MX-W22228BLLKC3	140 5.5118	250 9.8425	88 3.4627	1.0 0.039	10 0.3937	153,000	218,000
MX-W22232BLLKC3	160 6.2992	290 11.4173	104 4.0945	1.0 0.039	12 0.4724	196,000	290,000



Tapered Bore
MX-W222K
Taper 1:12

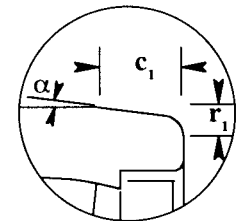

*Detail:

For outside diameter chamfer dimensions, contact NTN Engineering.

Note: The *d* dimensions for the tapered bore is measured from the side of the bearing with the smallest bore dimension. Lubrication holes and oil groove provided as standard, suffix D1 not needed.



Bearing Series →

213 SERIES

21308C.....

1.55 ←

Bearing Number

Weight (lbs)

SPHERICAL ROLLER BEARINGS

LBS.

213 SERIES		230 SERIES	
21308C.....	1.55	21308CK.....	1.53
21309C.....	2.04	21309CK.....	2.01
21310C.....	2.67	21310CK.....	2.62
21311.....	3.77	21311K.....	3.73
21312.....	4.63	21312K.....	4.56
21313.....	5.62	21313K.....	5.53
21314.....	7.01	21314K.....	6.92
21315.....	8.40	21315K.....	8.29
21316.....	9.99	21316K.....	9.85
21317.....	11.8	21317K.....	11.6
21318.....	13.9	21318K.....	13.7
21319.....	15.7	21319K.....	15.4
21320.....	19.6	21320K.....	19.4
222 SERIES		230 SERIES	
22208C.....	1.16	23022B.....	8.18
22209C.....	1.55	23024BD1.....	8.93
22210C.....	2.15	23026BD1.....	13.0
22211B.....	1.87	23028BD1.....	14.0
22212B.....	2.54	23030BD1.....	17.0
22213B.....	3.31	23032BD1.....	20.8
22214B.....	3.42	23034BD1.....	28.0
22215B.....	3.64	23036BD1.....	36.8
22216B.....	4.74	23038BD1.....	39.0
22217B.....	5.86	23040BD1.....	50.0
22218B.....	7.72	23044B.....	65.9
22219B.....	9.04	23048B.....	73.6
22220BD1.....	10.9	23052B.....	107
22222BD1.....	15.9	23056B.....	116
22224BD1.....	20.1	23060B.....	160
22226BD1.....	24.7	23064B.....	172
22228BD1.....	30.9	23068B.....	229
22230BD1.....	39.9	23072B.....	243
22232BD1.....	50.0	23076B.....	254
22234BD1.....	61.7	23080B.....	328
22236B.....	64.6	23084B.....	346
22238B.....	80.7	23088B.....	399
22240B.....	97.0	23092B.....	454
22244B.....	133	23096B.....	478
22248B.....	180	230/500B.....	498
22252B.....	234	230/530B.....	675
22256B.....	247	230/560B.....	778
22260B.....	311	230/600B.....	882
		230/630B.....	1060
		230/670B.....	1310
		230/710B.....	1460
		230/750B.....	1740
223 SERIES		231 SERIES	
22308C.....	2.15	23122BD1.....	11.9
22309C.....	2.93	23124BD1.....	17.0
22310C.....	3.95	23126BD1.....	18.7
22311B.....	5.07	23128BD1.....	22.5
22312B.....	6.39	23130BD1.....	34.4
22313B.....	7.61	23132BD1.....	43.7
22314B.....	9.30	23134BD1.....	47.4
22315B.....	11.6	23136BD1.....	55.3
22316B.....	13.3	23138B.....	77.8
22317BD1.....	15.7	23140B.....	95.5
22318BD1.....	18.4	23144B.....	118
22319BD1.....	21.5	23148B.....	145
22320BD1.....	27.3	23152B.....	202
22322BD1.....	37.7	23156B.....	215
22324BD1.....	47.4	23160B.....	289
22326BD1.....	59.1	23164B.....	368
22328BD1.....	74.5	23168B.....	463
22330B.....	94.1	23172B.....	489
22332B.....	112	23176B.....	518
22334B.....	132	23180B.....	582
22336B.....	154	23184B.....	780
22338B.....	179	23188B.....	816
22340B.....	205	23192B.....	977
22344B.....	258	23196B.....	1080
22348B.....	326	231/500B.....	1290
22352B.....	403	231/530B.....	1440
22356B.....	494	231/560B.....	1660
22360B.....	595	231/600B.....	2000
		231/630B.....	2310
		231/670B.....	2760
		231/710B.....	3130
		23122BKD1.....	11.5
		23124BKD1.....	16.4
		23126BKD1.....	18.1
		23128BKD1.....	21.7
		23130BKD1.....	33.3
		23132BKD1.....	42.3
		23134BKD1.....	45.9
		23136BKD1.....	53.4
		23138BK.....	75.4
		23140BK.....	92.6
		23144BK.....	114
		23148BK.....	141
		23152BK.....	195
		23156BK.....	209
		23160BK.....	280
		23164BK.....	357
		23168BK.....	450
		23172BK.....	474
		23176BK.....	503
		23180BK.....	564
		23184BK.....	756
		23188BK.....	789
		23192BK.....	946
		23196BK.....	1050
		231/500BK.....	1250
		231/530BK.....	1400
		231/560BK.....	1610
		231/600BK.....	1940
		231/630BK.....	2250
		231/670BK.....	2670
		231/710BK.....	3040



Bearing Series → **213 SERIES**

Bearing Number → 21308C 1.55 ← **Weight (lbs)**

SPHERICAL ROLLER BEARINGS **LBS.**

MX-W SERIES		240 SERIES	
MX-W22211BLLC3.....2.6	MX-W22211BLLKC3.....2.6	24024BD1.....12.1	24024BK30D1.....11.9
MX-W22213BLLC3.....4.2	MX-W22213BLLKC3.....4.2	24026BD1.....17.8	24026BK30D1.....17.5
MX-W22215BLLC3.....4.6	MX-W22215BLLKC3.....4.6	24028BD1.....18.9	24028BK30D1.....18.6
MX-W22217BLLC3.....6.2	MX-W22217BLLKC3.....6.2	24030BD1.....23.6	24030BK30D1.....23.1
MX-W22220BLLC3.....13.0	MX-W22220BLLKC3.....13.0	24032BD1.....28.7	24032BK30D1.....28.2
MX-W22222BLLC3.....18.7	MX-W22222BLLKC3.....18.7	24034BD1.....39.0	24034BK30D1.....38.4
MX-W22224BLLC3.....24.0	MX-W22224BLLKC3.....24.0	24036BD1.....51.4	24036BK30D1.....50.5
MX-W22226BLLC3.....28.4	MX-W22226BLLKC3.....28.4	24038BD1.....53.6	24038BK30D1.....52.7
MX-W22228BLLC3.....36.2	MX-W22228BLLKC3.....36.2	24040BD1.....68.3	24040BK30D1.....67.2
MX-W22232BLLC3.....59.5	MX-W22232BLLKC3.....59.5	24044B.....88.6	24044BK30.....87.3
		24048B.....94.8	24048BK30.....93.3
		24052B.....144	24052BK30.....141
		24056B.....152	24056BK30.....150
		24060B.....216	24060BK30.....213
		24064B.....227	24064BK30.....223
		24068B.....309	24068BK30.....304
		24072B.....324	24072BK30.....320
		24076B.....337	24076BK30.....331
		24080B.....445	24080BK30.....441
		24084B.....463	24084BK30.....456
		24088B.....540	24088BK30.....531
		24092B.....608	24092BK30.....600
		24096B.....628	24096BK30.....617
		240/500B.....650	240/500BK30.....639
232 SERIES		241 SERIES	
23218B.....9.81	23218BK.....9.52	24122BD1.....15.6	24122BK30D1.....15.3
23220B.....14.3	23220BK.....13.8	24124BD1.....22.7	24124BK30D1.....22.3
23222BD1.....21.4	23222BKD1.....20.8	24126BD1.....24.3	24126BK30D1.....23.8
23224BD1.....26.7	23224BKD1.....25.8	24128BD1.....29.3	24128BK30D1.....28.9
23226BD1.....31.5	23226BKD1.....30.6	24130BD1.....44.5	24130BK30D1.....44.1
23228BD1.....41.4	23228BKD1.....40.1	24132BD1.....57.3	24132BK30D1.....56.4
23230BD1.....53.1	23230BKD1.....51.6	24134BD1.....60.0	24134BK30D1.....59.1
23232BD1.....66.1	23232BKD1.....64.2	24136BD1.....75.6	24136BK30D1.....74.5
23234BD1.....81.1	23234BKD1.....78.7	24138B.....94.4	24138BK30.....93.0
23236B.....86.0	23236BK.....83.3	24140B.....118	24140BK30.....116
23238B.....105	23238BK.....102	24144B.....148	24144BK30.....146
23240B.....126	23240BK.....122	24148B.....181	24148BK30.....178
23244B.....176	23244BK.....171	24152B.....251	24152BK30.....247
23248B.....238	23248BK.....231	24156B.....265	24156BK30.....260
23252B.....311	23252BK.....302	24160B.....355	24160BK30.....351
23256B.....331	23256BK.....320	24164B.....567	24164BK30.....450
23260B.....425	23260BK.....412	24168B.....593	244168BK30.....584
23264B.....536	23264BK.....520	24172B.....619	24172BK30.....611
23268B.....661	23268BK.....642	24176B.....644	24176BK30.....633
23272B.....747	23272BK.....725	24180B.....725	24180BK30.....714
23276B.....838	23276BK.....814	24184B.....970	24184BK30.....955
23280B.....1010	23280BK.....977	24188B.....1010	24188BK30.....990
23284B.....1200	23284BK.....1160	24192B.....1210	24192BK30.....1190
23288B.....1320	23288BK.....1280	24196B.....1340	24196BK30.....1320
23292B.....1550	23292BK.....1510	241/500B.....1580	241/500BK30.....1550
23296B.....1790	23296BK.....1740		
232/500B.....2200	232/500BK.....2140	22314UAVS1 SERIES	
232/530B.....2650	232/530BK.....2580	22314UAVS1.....9.48	
232/560B.....3000	232/560BK.....2910	22315UAVS1.....11.6	
232/600B.....3400	232/600BK.....3280	22316UAVS1.....13.8	
232/630B.....4190	232/630BK.....4060	22317UAVS1.....16.0	
232/670B.....5000	232/670BK.....4850	22318UAVS1.....19.1	
232/710B.....5600	232/710BK.....5450	22319UAVS1.....21.9	
232/750B.....6720	232/750BK.....6530	22320UAVS1.....28.4	
		22322UAVS1.....39.9	
		22324UAVS1.....48.1	
		22326UAVS1.....62.4	
		22328UAVS1.....75.9	
		22330UAVS1.....91.1	
		22332UAVS1.....108	
		22334UAVS1.....132	
		22336UAVS1.....149	
		22338UAVS1.....174	
		22340UAVS1.....199	
239 SERIES			
23932D1.....12.1	23932KD1.....11.8		
23934D1.....12.8	23934KD1.....12.4		
23936D1.....18.1	23936KD1.....17.5		
23938D1.....19.0	23938KD1.....18.4		
23940D1.....26.7	23940KD1.....25.8		
23944D1.....28.9	23944KD1.....28.0		
23948.....30.9	23948K.....30.0		
23952.....52.9	23952K.....51.4		
23956.....58.2	23956K.....56.4		
23960.....88.2	23960K.....85.3		
23964.....94.8	23964K.....91.9		
23968.....98.5	23968K.....95.5		
23972.....104	23972K.....101		
23976.....154	23976K.....149		
23980.....161	23980K.....156		
23984.....168	23984K.....163		
23988.....223	23988K.....216		
23992.....236	23992K.....229		
23996.....271	23996K.....262		
239/500.....289	239/500K.....280		
239/530.....346	239/530K.....335		
239/560.....401	239/560K.....388		
239/600.....481	239/600K.....465		
239/630.....611	239/630K.....591		
239/670.....699	239/670K.....677		
239/710.....827	239/710K.....800		
239/750.....908	239/750K.....880		
239/800.....1070	239/800K.....1040		
239/850.....1210	239/850K.....1170		
239/900.....1370	239/900K.....1330		



- Accurate and finely ground tapered surface
- Minimal eccentricity

- Narrow slot type (Bore nos. -05 to 13)
- Precisely Machined screw thread

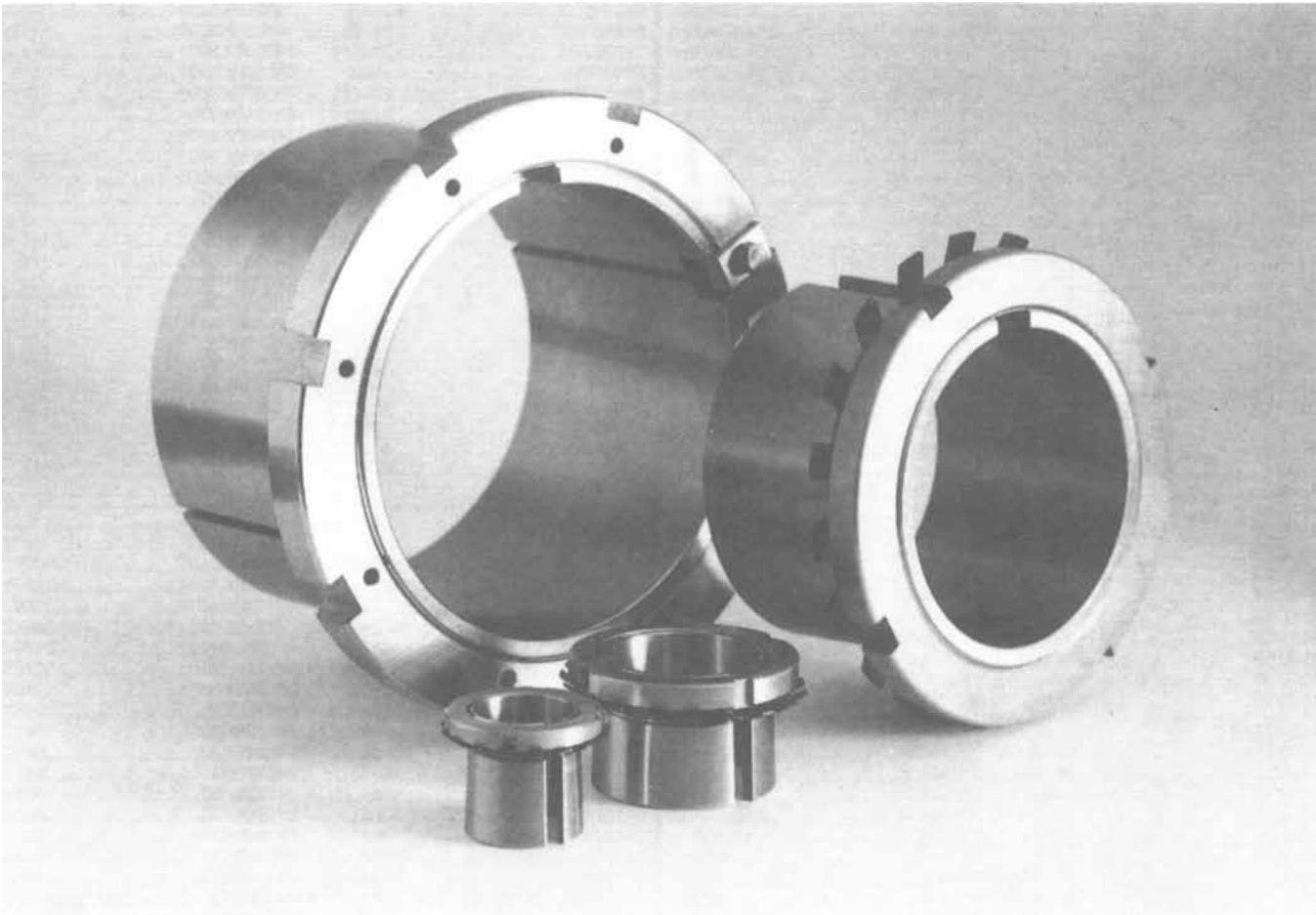

Note:



The Lockwasher with the straight inner tab must be used with the narrow slot type of adapter sleeve (suffix X)

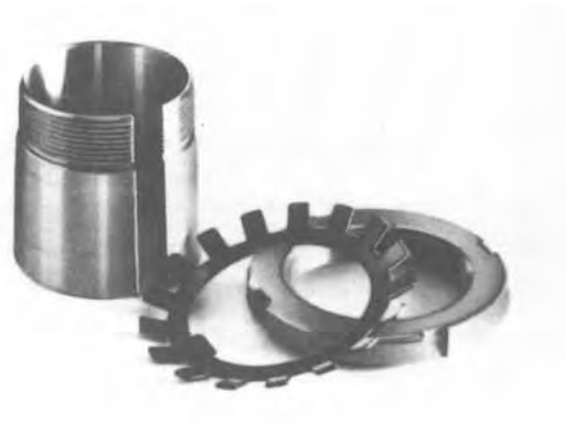

Either the bent tab or the strait tab type may be used with the wide slot type of adapter sleeve (without suffix X).

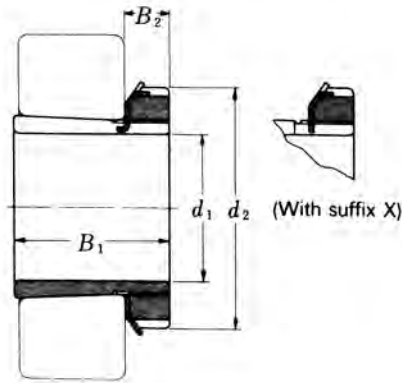

NTN
SERIES
H2, HE2,
HS2, HA2
H3, HE3,
HS3, HA3

Adapter No.				d_1				B_1		d_2	B_2	Weight	
H	HE	HS	HA	H mm	HE in.	HS in.	HA in.	mm	in.	mm	mm	kg	lbs.
H204	—	—	—	17	—	—	—	24	0.945	32	7	0.041	0.090
H205X	HE205	—	—	20	3/4	—	—	26	1.024	38	8	0.070	0.154
H206X	HE206	HS206	HA206	25	1	7/8	1 5/16	27	1.063	45	8	0.099	0.218
H207X	—	HS207	HA207X	30	—	1 1/8	1 3/16	29	1.142	52	9	0.125	0.276
H208X	HE208X	HS208X	HA208X	35	1 1/4	1 3/8	1 5/16	31	1.220	58	10	0.174	0.384
H209X	HE209X	HS209	HA209	40	1 1/2	1 5/8	1 7/16	33	1.299	65	11	0.227	0.500
H210X	HE210X	HS210	HA210	45	1 3/4	1 5/8	1 11/16	35	1.378	70	12	0.274	0.604
H211X	HE211XY	HS211	HA211	50	2	1 7/8	1 15/16	37	1.457	75	12	0.308	0.679
H213X	—	HS212	—	55	—	2 1/8	—	38	1.496	80	13	0.346	0.763
H213X	HE213X	HS213	HA213	60	2 1/4	2 3/8	2 3/16	40	1.575	85	14	0.401	0.884
H215X	HE215X	—	HA215	65	2 1/2	—	2 7/16	43	1.693	98	15	0.707	1.560
H216X	HE216X	—	HA216	70	2 3/4	—	2 11/16	46	1.811	105	17	0.882	1.940
H217X	HE217X	—	HA217X	75	3	—	2 15/16	50	1.969	110	18	1.020	2.250
H218X	—	—	HA218	80	—	—	3 3/16	52	2.047	120	18	1.190	2.620
H219X	HE219X	—	—	85	3 1/4	—	—	55	2.165	125	19	1.370	3.020
H220X	HE220X	—	HA220	90	3 1/2	—	3 7/16	58	2.283	130	20	1.490	3.280
H222X	HE222X	—	HA222X	100	4	—	3 15/16	63	2.480	145	21	1.930	4.250

Adapter No.				d_1				B_1		d_2	B_2	Weight	
H	HE	HS	HA	H mm	HE in.	HS in.	HA in.	mm	in.	mm	mm	kg	lbs.
H304	—	—	—	17	—	—	—	28	1.102	32	7	0.045	0.099
H305X	HE305	—	—	20	3/4	—	—	29	1.142	38	8	0.075	0.165
H306X	HE306X	HS306	HA306	25	1	7/8	1 5/16	31	1.220	45	8	0.109	0.240
H307X	—	HS307	HA307X	30	—	1 1/8	1 3/16	35	1.378	52	9	0.142	0.313
H308X	HE308X	HS308X	HA308X	35	1 1/4	1 3/8	1 5/16	36	1.417	58	10	0.189	0.417
H309X	HE309X	HS309	HA309	40	1 1/2	1 5/8	1 7/16	39	1.535	65	11	0.248	0.547
H310X	HE310X	HS310	HA310	45	1 3/4	1 5/8	1 11/16	42	1.654	70	12	0.303	0.668
H311X	HE311XY	HS311	HA311	50	2	1 7/8	1 15/16	45	1.772	75	12	0.345	0.761
H312X	—	HS312	HA312	55	—	2 1/8	—	47	1.850	80	13	0.394	0.869
H313X	HE313X	HS313	HA313	60	2 1/4	2 3/8	2 3/16	50	1.969	85	14	0.458	1.010
H315X	HE315X	—	HA315	65	2 1/2	—	2 7/16	55	2.165	98	15	0.831	1.830
H316X	HE316X	—	HA316	70	2 3/4	—	2 11/16	59	2.323	105	17	1.030	2.270
H317X	HE317X	—	HA317X	75	3	—	2 15/16	63	2.480	110	18	1.180	2.600
H318X	—	—	HA318	80	—	—	3 3/16	65	2.559	120	18	1.370	3.020
H319X	HE319X	—	—	85	3 1/4	—	—	68	2.677	125	19	1.560	3.440
H320X	HE320X	—	HA320	90	3 1/2	—	3 7/16	71	2.795	130	20	1.690	3.730
H322X	HE322X	—	HA322X	100	4	—	3 15/16	77	3.031	145	21	2.180	4.810

- Notes: 1. The adapter no. denotes the complete assembly of adapter sleeve, locknut and lockwasher or lockplate.
2. Suffix X denotes the narrow slot type of adapter sleeve. The straight inner tab type of lockwasher (also denoted by suffix X) should be used with sleeve.
3. Suffix Y denotes a non-standard thread. This is necessary in certain cases because of the thin section of the sleeve.
4. The weights given in above table are for adapters of type H. There is little difference in the weights of other types of the same size.

NTN
SERIES
H 23
HE23
HS23
HA23

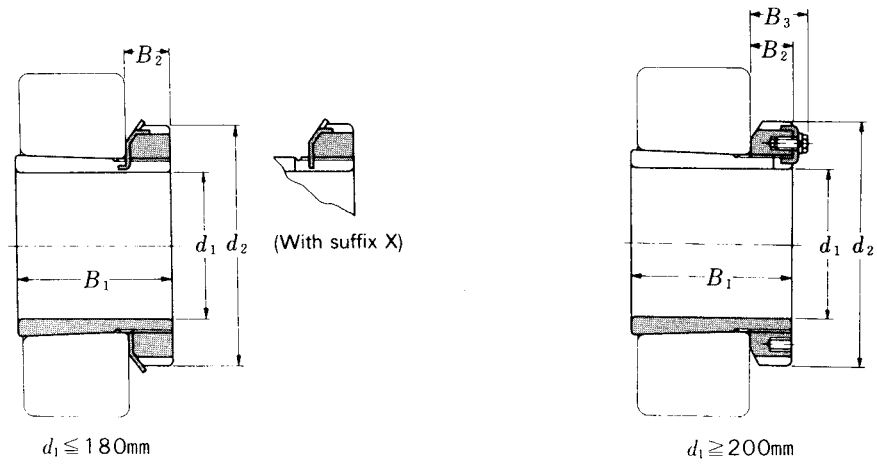

Adapter No.				d_1				B_1		d_2	B_2	B_3^*	Weight	
H	HE	HS	HA	H mm	HE in.	HS in.	HA in.	mm	in.	mm	mm	mm	kg	lbs.
H2304	—	—	—	17	—	—	—	31	1.102	32	7	—	0.049	0.108
H2305X	HE2305	—	—	20	3/4	—	—	35	1.142	38	8	—	0.087	0.192
H2306X	HE2306X	HS2306	—	25	1	7/8	—	38	1.220	45	8	—	0.126	0.278
H2307X	—	HS2307	—	30	—	1 1/8	—	43	1.378	52	9	—	0.165	0.364
H2308X	HE2308X	HS2308X	—	35	1 1/4	1 3/8	—	46	1.417	58	10	—	0.224	0.494
H2309X	HE2309X	HS2309X	HA2309	40	1 1/2	1 5/8	1 7/16	50	1.535	65	11	—	0.280	0.617
H2310X	HE2310X	HS2310	HA2310	45	1 3/4	1 5/8	1 11/16	55	1.654	70	12	—	0.362	0.798
H2311X	HE2311XY	HS2311	HA2311	50	2	1 7/8	1 15/16	59	1.772	75	12	—	0.420	0.926
H2312X	—	HS2312	—	55	—	2 1/8	—	62	1.850	80	13	—	0.481	1.06
H2313X	HE2313X	HS2313X	HA2313	60	2 1/4	2 3/8	2 3/16	65	1.969	85	14	—	0.557	1.23
H2315X	HE2315X	—	HA2315	65	2 1/2	—	2 7/16	73	2.165	98	15	—	1.050	2.31
H2316X	HE2316X	—	HA2316	70	2 3/4	—	2 11/16	78	2.323	105	17	—	1.280	2.82
H2317X	HE2317X	—	HA2317X	75	3	—	2 15/16	82	2.480	110	18	—	1.450	3.20
H2318X	—	—	HA2318	80	—	—	3 3/16	86	2.559	120	18	—	1.690	3.73
H2319X	HE2319X	—	—	85	3 1/4	—	—	90	2.677	125	19	—	1.920	4.23
H2320X	HE2320X	—	HA2320	90	3 1/2	—	3 7/16	97	2.795	130	20	—	2.150	4.74
H2322X	HE2322X	—	HA2322X	100	4	—	3 15/16	105	3.031	145	21	—	2.740	6.04
H2324X	HE2324	—	HA2324	110	4 1/4	—	4 3/16	112	4.409	155	22	—	3.190	7.03
H2326	HE2326	—	HA2326	115	4 1/2	—	4 7/16	121	4.764	165	23	—	4.600	10.1
H2328	HE2328	—	HA2328	125	5	—	4 15/16	131	5.157	180	24	—	5.550	12.2
H2330	HE2330	—	HA2330	135	5 1/4	—	5 3/16	139	5.472	195	26	—	6.630	14.6
H2332	HE2332	—	HA2332	140	5 1/2	—	5 7/16	147	5.787	210	28	—	9.140	20.2
H2334	HE2334	—	HA2334	150	6	—	5 15/16	154	6.063	220	29	—	10.200	22.5
H2336	HE2336	—	HA2336	160	6 1/4	—	6 7/16	161	6.339	230	30	—	11.300	24.9
H2338	HE2338	—	HA2338	170	6 1/2	—	6 15/16	169	6.654	240	31	—	12.600	27.8
H2340	HE2340	—	HA2340	180	7	—	7 3/16	176	6.929	250	32	—	13.900	30.6
H2344	—	—	—	200	—	—	—	183	7.205	280	32	44	16.700	36.8
H2348	—	—	—	220	—	—	—	196	7.717	300	34	46	19.700	43.4
H2352	—	—	—	240	—	—	—	208	8.189	330	36	49	24.200	53.4
H2356	—	—	—	260	—	—	—	221	8.701	350	38	51	27.800	61.3

* Adapters with the dimension B_3 have a locking device as shown in the right illustration.

- Notes: 1. The adapter no. denotes the complete assembly of adapter sleeve, locknut and lockwasher or lockplate.
 2. Suffix X denotes the narrow slot type of adapter sleeve. The straight inner tab type of lockwasher (also denoted by suffix X) should be used with sleeve.
 3. Suffix Y denotes a non-standard thread. This is necessary in certain cases because of the thin section of the sleeve.
 4. The weights given in above table are for adapters of type H. There is little difference in the weights of other types of the same size.

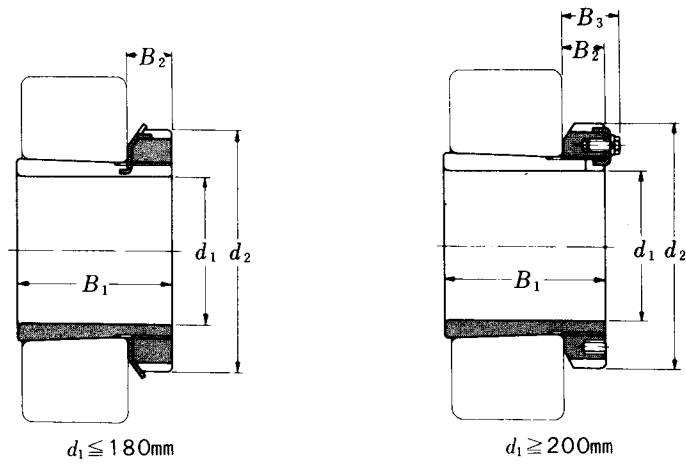

Adapter No.			d_1			B_1		d_2	B_2	B_3^*	Weight	
H	HE	HA	H mm	HE in.	HA in.	mm	in.	mm	mm	mm	kg	lbs.
H3122X	HE3122X	HA3122	100	4	3 15/16	81	3.189	145	21	—	2.250	4.96
H3124X	HE3124X	HA3124	110	4 1/4	4 3/16	88	3.465	155	22	—	2.640	5.82
H3126	HE3126	HA3126	115	4 1/2	4 7/16	92	3.622	165	23	—	3.660	8.07
H3128	HE3128	HA3128	125	5	4 15/16	97	3.819	180	24	—	4.340	9.57
H3130	HE3130	HA3130	135	5 1/4	5 3/16	111	4.370	195	26	—	5.520	12.2
H3132	HE3132	HA3132	140	5 1/2	5 7/16	119	4.685	210	28	—	7.670	16.9
H3134	HE3134	HA3134	150	6	5 15/16	122	4.803	220	29	—	8.380	18.5
H3136	HE3136	HA3136	160	6 1/2	6 7/16	131	5.157	230	30	—	9.500	20.9
H3138	HE3138	HA3138	170	6 3/4	6 15/16	141	5.551	240	31	—	10.800	23.8
H3140	HE3140	HA3140	180	7	7 3/16	150	5.906	250	32	—	12.100	26.7
H3144	—	HA3144	200	—	7 15/16	158	6.220	280	32	44	14.700	32.4
H3148	—	—	220	—	—	169	6.654	300	34	46	17.300	38.1
H3152	—	—	240	—	—	187	7.362	330	36	49	22.000	48.5
H3156	—	—	260	—	—	192	7.559	350	38	51	24.500	54.0
H3160	—	—	280	—	—	208	8.189	380	40	53	30.200	66.6
H3164	—	—	300	—	—	226	8.898	400	42	56	34.900	77.0
H3168	—	—	320	—	—	254	10.000	440	55	72	49.500	109
H3172	—	—	340	—	—	259	10.197	460	58	75	54.200	119
H3176	—	—	360	—	—	264	10.394	490	60	77	61.700	136
H3180	—	—	380	—	—	272	10.709	520	62	82	70.600	156
H3184	—	—	400	—	—	304	11.969	540	70	90	84.200	186
H3188	—	—	410	—	—	307	12.087	560	70	90	104.000	229
H3192	—	—	430	—	—	326	12.835	580	75	95	116.000	256
H3196	—	—	450	—	—	335	13.189	620	75	95	133.000	293
H31/500	—	—	470	—	—	356	14.016	630	80	100	143.000	315

* Adapters with the dimension B_3 have a locking device as shown in the right illustration.

Notes: The weights given in above table are for adapters of type H. There is little difference in the weights of other types of the same size.

NTN
LOCKNUTS
AND
LOCKWASHERS
INCH

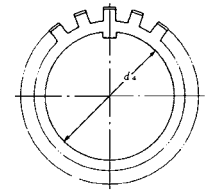
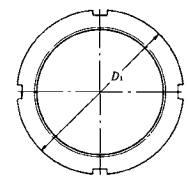
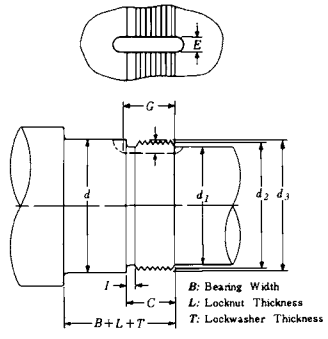

Locknut

Lockwasher

LOCKNUTS AND LOCKWASHERS

For Bearing with this Bore Number	LOCKNUT NUMBER	LOCKWASHER NUMBER	Shaft Dimensions											Locknut Dimensions		Lockwasher Dimensions		
			d Nominal		d ₃ Thread O. D.		d ₂ Thread Pitch Diameter		Threads per inch	d ₁ (inch) Extension Diameter Maximum	C (inch)	G (inch)	I (inch)	E (inch)	D ₁ (inch)	L (inch)	T (inch)	d ₄ (inch)
			(mm)	(inch)	Maximum	Tolerance +.0000	Maximum	Tolerance +.0000										
05	N05	W05	25	.9843	.969	-.0054	.9487	-.0034	32	7/8	15/32	19/32	1/16	3/16	1 9/16	1 3/32	.050	1.000
06	N06	W06	30	1.1811	1.173	-.0082	1.1369	-.0040	18	1 1/16	15/32	19/32	3/32	3/16	1 3/4	1 3/32	.050	1.199
07	N07	W07	35	1.3780	1.376	-.0082	1.3399	-.0040	18	1 1/4	1/2	5/8	3/32	3/16	2 1/16	7/16	.050	1.407
08	N08	W08	40	1.5748	1.563	-.0082	1.5269	-.0045	18	1 15/32	17/32	21/32	3/32	5/16	2 1/4	7/16	.058	1.593
09	N09	W09	45	1.7717	1.767	-.0082	1.7309	-.0045	18	1 11/16	17/32	11/16	1/8	5/16	2 17/32	7/16	.058	1 13/16
10	N10	W10	50	1.9685	1.967	-.0082	1.9309	-.0045	18	1 7/8	19/32	3/4	1/8	5/16	2 11/16	1/2	.058	2
11	N11	W11	55	2.1654	2.157	-.0082	2.1209	-.0051	18	2 1/16	19/32	3/4	1/8	5/16	2 31/32	1/2	.063	2 3/16
12	N12	W12	60	2.3622	2.360	-.0082	2.3239	-.0051	18	2 1/4	9/8	25/32	1/8	5/16	3 3/32	17/32	.063	2 13/32
13	N13	W13	65	2.5591	2.548	-.0082	2.5119	-.0051	18	2 7/16	21/32	13/16	1/8	5/16	3 3/8	9/16	.063	2 19/32
14	N14	W14	70	2.7559	2.751	-.0082	2.7149	-.0051	18	2 5/8	21/32	29/32	1/8	5/16	3 5/8	9/16	.063	2 13/16
15	AN15A	W15	75	2.9528	2.933	-.0112	2.8789	-.0054	12	2 25/32	11/16	15/16	5/32	5/16	3 7/8	19/32	.072	3
16	AN16A	W16	80	3.1496	3.137	-.0112	3.0829	-.0059	12	3	1 1/16	1 5/16	3/32	3/8	4 3/32	19/32	.072	3 3/16
17	AN17A	W17	85	3.3465	3.340	-.0112	3.2859	-.0074	12	3 3/16	23/32	31/32	5/32	3/8	4 13/32	5/8	.072	3 13/32
18	AN18A	W18	90	3.5433	3.527	-.0112	3.4729	-.0074	12	3 3/8	13/16	1 1/16	5/32	3/8	4 21/32	11/16	.094	3 19/32
19	AN19A	W19	95	3.7402	3.730	-.0112	3.6759	-.0074	12	3 9/16	27/32	1 3/32	5/32	3/8	4 15/16	23/32	.094	3 13/16
20	AN20A	W20	100	3.9370	3.918	-.0112	3.8639	-.0074	12	3 25/32	7/8	1 3/16	5/32	3/8	5 3/16	3/4	.094	4
21	AN21A	W21	105	4.1339	4.122	-.0112	4.0679	-.0083	12	3 15/16	7/8	1 3/16	5/32	3/8	5 1/16	3/4	.094	4 7/32
22	AN22A	W22	110	4.3307	4.325	-.0112	4.2709	-.0083	12	4 3/16	29/32	1 7/32	5/32	3/8	5 23/32	25/32	.125	4 13/32
24	AN24A	W24	120	4.7244	4.716	-.0112	4.6619	-.0083	12	4 9/16	1 5/16	1 1/4	5/32	3/8	6 1/8	13/16	.125	4 13/16
26	AN26A	W26	130	5.1181	5.106	-.0112	5.0519	-.0083	12	4 15/16	1	1 5/16	5/32	1/2	6 3/4	7/8	.125	5 7/32
28	AN28A	W28	140	5.5118	5.497	-.0112	5.4429	-.0083	12	5 5/16	1 1/16	1 3/8	3/32	5/8	7 3/32	1 5/16	.125	5 19/32
30	AN30A	W30	150	5.9055	5.888	-.0112	5.8339	-.0083	12	5 23/32	1 1/8	1 1/2	5/32	5/8	7 11/16	31/32	.156	6
32	AN32A	W32	160	6.2992	6.284	-.0152	6.2028	-.0091	8	6 1/8	1 3/16	1 9/16	1/4	5/8	8 1/16	1 1/32	.156	6 13/32
34	AN34A	W34	170	6.6929	6.659	-.0152	6.5778	-.0091	8	6 1/2	1 7/32	1 19/32	1/4	3/4	8 21/32	1 1/16	.156	6 25/32
36	AN36A	W36	180	7.0866	7.066	-.0152	6.9848	-.0091	8	6 29/32	1 1/4	1 5/8	1/4	3/4	9 1/16	1 3/32	.156	7 3/16
38	AN38A	W38	190	7.4803	7.472	-.0152	7.3908	-.0091	8	7 5/16	1 9/32	1 21/32	1/4	3/4	9 15/32	1 1/8	.156	7 19/32
40	AN40A	W40	200	7.8740	7.847	-.0152	7.7658	-.0114	8	7 11/16	1 11/32	1 23/32	1/4	7/8	9 27/32	1 3/16	.156	8
44	N44	W44	220	8.6614	8.628	-.0152	8.5468	-.0121	8	8 5/16	1 3/8	1 9/16	1/4	1 1/16	11	1 1/4	.156	8 45/64
22	N022	W022	110	4.3307	4.325	-.0112	4.2709	-.0083	12	4 3/16	29/32	1 7/32	5/32	3/8	5 5/16	25/32	.125	4 13/32
24	N024	W024	120	4.7244	4.716	-.0112	4.6619	-.0083	12	4 9/16	1 5/16	1 1/4	5/32	3/8	5 11/16	13/16	.125	4 13/16
26	N026	W026	130	5.1181	5.106	-.0112	5.0519	-.0083	12	4 15/16	1	1 5/16	5/32	1/2	6 1/8	7/8	.125	5 7/32
28	N028	W028	140	5.5118	5.497	-.0112	5.4429	-.0083	12	5 5/16	1 1/16	1 3/8	5/32	5/8	6 1/2	1 5/16	.125	5 19/32
30	N030	W030	150	5.9055	5.888	-.0112	5.8339	-.0083	12	5 23/32	1 1/8	1 1/2	5/32	5/8	7 1/8	31/32	.125	6
32	N032	W032	160	6.2992	6.284	-.0152	6.2028	-.0091	8	6 1/8	1 3/16	1 9/16	1/4	5/8	7 1/2	1 1/32	.125	6 13/32
34	N034	W034	170	6.6929	6.659	-.0152	6.5778	-.0091	8	6 1/2	1 7/32	1 19/32	1/4	3/4	7 7/8	1 1/16	.125	6 25/32
36	N036	W036	180	7.0866	7.066	-.0152	6.9848	-.0091	8	6 29/32	1 1/4	1 5/8	1/4	3/4	8 1/4	1 3/32	.125	7 3/16
38	N038	W038	190	7.4803	7.472	-.0152	7.3908	-.0091	8	7 5/16	1 9/32	1 21/32	1/4	3/4	8 11/16	1 1/8	.125	7 19/32
40	N040	W040	200	7.8740	7.847	-.0152	7.7658	-.0114	8	7 11/16	1 11/32	1 23/32	1/4	7/8	9 7/16	1 3/16	.125	8
44	N044	W044	220	8.6614	8.628	-.0152	8.5468	-.0121	8	8 5/16	1 3/8	1 9/16	1/4	1 1/16	10 1/4	1 1/4	.125	8 45/64

Threads are derived from the Screw Thread Standards for Federal services Handbook H-28.
Tolerance: + 1/64 to -0 inch

LOCKNUTS AND LOCKWASHERS

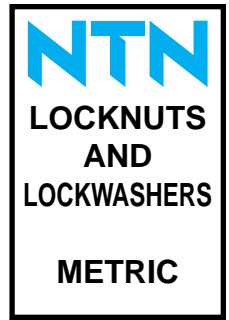

For Bearing with Bore Number	Locknut Number	Lockwasher Number	Thread Size	Threads per mm	Dimensions (mm)						Shaft Diameter (mm)
					<i>d</i>	<i>d</i> ₁	<i>d</i> ₂	<i>g</i>	<i>b</i>	<i>h</i>	
—	AN00	AW00	M10 X 75	.75	13	18	14	3	2	4	10
—	AN01	AW01	M12 X 1	1.0	17	22	18	3	2	4	12
—	AN02	AW02	M15 X 1	1.0	21	25	21	4	2	5	15
—	AN03	AW03	M17 X 1	1.0	24	28	24	4	2	5	17
04	AN04	AW04	M20 X 1	1.0	26	32	28	4	2	6	20
05	AN05	AW05	M25 X 1.5	1.5	32	38	34	5	2	7	25
06	AN06	AW06	M30 X 1.5	1.5	38	45	41	5	2	7	30
07	AN07	AW07	M35 X 1.5	1.5	44	52	48	5	2	8	35
08	AN08	AW08	M40 X 1.5	1.5	50	58	53	6	2.5	9	40
09	AN09	AW09	M45 X 1.5	1.5	56	65	60	6	2.5	10	45
10	AN10	AW10	M50 X 1.5	1.5	61	70	65	6	2.5	11	50
11	AN11	AW11	M55 X 2	2.0	67	75	69	7	3	11	55
12	AN12	AW12	M60 X 2	2.0	73	80	74	7	3	11	60
13	AN13	AW13	M65 X 2	2.0	79	85	79	7	3	12	65
14	AN14	AW14	M70 X 2	2.0	85	92	85	8	3.5	12	70
15	AN15	AW15	M75 X 2	2.0	90	98	91	8	3.5	13	75
16	AN16	AW16	M80 X 2	2.0	95	105	98	8	3.5	15	80
17	AN17	AW17	M85 X 2	2.0	102	110	103	8	3.5	16	85
18	AN18	AW18	M90 X 2	2.0	108	120	112	10	4	16	90
19	AN19	AW19	M95 X 2	2.0	113	125	117	10	4	17	95
20	AN20	AW20	M100 X 2	2.0	120	130	122	10	4	18	100
21	AN21	AW21	M105 X 2	2.0	126	140	130	12	5	18	105
22	AN22	AW22	M110 X 2	2.0	133	145	135	12	5	19	110
—	AN23	AW23	M115 X 2	2.0	137	150	140	12	5	19	115
24	AN24	AW24	M120 X 2	2.0	138	155	145	12	5	20	120
—	AN25	AW25	M125 X 2	2.0	148	160	150	12	5	21	125
26	AN26	AW26	M130 X 2	2.0	149	165	155	12	5	21	130
—	AN27	AW27	M135 X 2	2.0	160	175	163	14	6	22	135
28	AN28	AW28	M140 X 2	2.0	160	180	168	14	6	22	140
—	AN29	AW29	M145 X 2	2.0	171	190	178	14	6	24	145
30	AN30	AW30	M150 X 2	2.0	171	195	183	14	6	24	150
—	AN31	AW31	M155 X 3	3.0	182	200	186	16	7	25	155
32	AN32	AW32	M160 X 3	3.0	182	210	196	16	7	25	160
—	AN33	AW33	M165 X 3	3.0	193	210	196	16	7	26	165
34	AN34	AW34	M170 X 3	3.0	193	220	206	16	7	26	170
36	AN36	AW36	M180 X 3	3.0	203	230	214	18	8	27	180
38	AN38	AW38	M190 X 3	3.0	214	240	224	18	8	28	190
40	AN40	AW40	M200 X 3	3.0	226	250	234	18	8	29	200
44	AN44	AL44	Tr220 X 4	4.0	250	280	260	20	10	32	220
48	AN48	AL44	Tr240 X 4	4.0	270	300	280	20	10	34	240
52	AN52	AL52	Tr260 X 4	4.0	300	330	306	24	12	36	260
56	AN56	AL52	Tr280 X 4	4.0	320	350	326	24	12	38	280
60	AN60	AL60	Tr300 X 4	4.0	340	380	356	24	12	40	300
64	AN64	AL64	Tr320 X 5	5.0	360	400	376	24	12	42	320
68	AN68	AL68	Tr340 X 5	5.0	400	440	410	28	15	55	340
72	AN72	AL68	Tr360 X 5	5.0	420	460	430	28	15	58	360
76	AN76	AL76	Tr380 X 5	5.0	450	490	454	32	18	60	380
80	AN80	AL80	Tr400 X 5	5.0	470	520	484	32	18	62	400
84	AN84	AL80	Tr420 X 5	5.0	490	540	504	32	18	70	420
88	AN88	AL88	Tr440 X 5	5.0	510	560	520	36	20	70	440
92	AN92	AL88	Tr460 X 5	5.0	540	580	540	36	20	75	460
96	AN96	AL96	Tr480 X 5	5.0	560	620	580	36	20	75	480
/500	AN100	AL100	Tr500 X 5	5.0	580	630	584	40	23	80	800

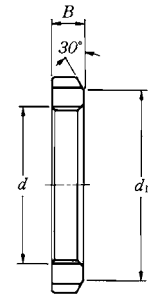
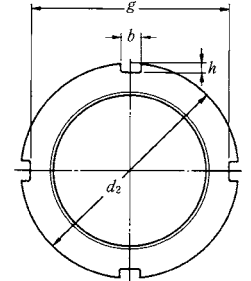



LOCKNUTS AND LOCKWASHERS							
— INCH SIZES —				— METRIC SIZES —			
Locknut Number	Weight (lbs)	Lockwasher Number	Weight (oz)	Locknut Number	Weight (lbs)	Lockwasher Number	Weight (oz)
N05	.12	W05	.16	AN00	.01	AW00	.05
N06	.14	W06	.18	AN01	.02	AW01	.07
N07	.22	W07	.26	AN02	.02	AW02	.09
N08	.24	W08	.39	AN03	.03	AW03	.11
N09	.31	W09	.48	AN04	.04	AW04	.12
N10	.36	W10	.49	AN05	.06	AW05	.23
N11	.44	W11	.59	AN06	.09	AW06	.28
N12	.49	W12	.61	AN07	.12	AW07	.37
N13	.59	W13	.71	AN08	.19	AW08	.43
N14	.67	W14	.81	AN09	.26	AW09	.54
AN15A	.83	W15	1.19	AN10	.33	AW10	.56
AN16A	.96	W16	1.37	AN11	.35	AW11	.69
AN17A	1.10	W17	1.42	AN12	.38	AW12	.89
AN18A	1.37	W18	2.21	AN13	.45	AW13	1.02
AN19A	1.63	W19	2.47	AN14	.53	AW14	1.18
AN20A	1.89	W20	2.76	AN15	.63	AW15	1.26
AN21A	1.99	W21	2.94	AN16	.88	AW16	1.64
AN22A	2.33	W22	4.60	AN17	.99	AW17	1.85
AN24A	2.55	W24	4.90	AN18	1.23	AW18	2.20
AN26A	3.53	W26	6.21	AN19	1.45	AW19	2.36
AN28A	3.92	W28	6.40	AN20	1.54	AW20	2.70
AN30A	4.89	W30	9.71	AN21	1.86	AW21	2.91
AN32A	5.55	W32	9.92	AN22	2.13	AW22	3.32
AN34A	6.93	W34	12.22	AN23	2.23	AW23	3.81
AN36A	7.35	W36	12.87	AN24	2.38	AW24	3.70
AN38A	7.99	W38	13.46	AN25	2.62	AW25	4.16
AN40A	8.86	W40	13.88	AN26	2.76	AW26	3.99
N44	11.85	W44	19.41	AN27	3.42	AW27	5.08
N022	1.62	W022	3.39	AN28	3.44	AW28	5.01
N024	1.82	W024	3.75	AN29	4.41	AW29	5.93
N026	2.21	W026	4.02	AN30	4.48	AW30	5.82
N028	2.50	W028	4.39	AN31	4.87	AW31	7.37
N030	3.42	W030	6.21	AN32	5.71	AW32	7.83
N032	3.89	W032	6.53	AN33	5.36	AW33	8.50
N034	4.25	W034	6.98	AN34	6.17	AW34	8.71
N036	4.50	W036	7.16	AN36	6.77	AW36	9.45
N038	5.02	W038	7.41	AN38	7.47	AW38	9.81
N040	7.10	W040	9.01	AN40	8.14	AW40	10.34
N044	8.20	W044	9.58	AN44	11.47	AL44	.92
				AN48	13.12	AL44	.92
				AN52	17.75	AL52	1.20
				AN56	19.96	AL52	1.20
				AN60	26.02	AL60	1.34
				AN64	28.89	AL64	1.89
				AN68	50.94	AL68	2.35
				AN72	55.35	AL68	2.35
				AN76	68.13	AL76	2.81
				AN80	81.36	AL80	2.89
				AN84	95.92	AL80	2.89
				AN88	99.89	AL88	3.17
				AN92	111.13	AL88	3.17
				AN96	137.15	AL96	3.67
				AN100	139.58	AL100	3.70

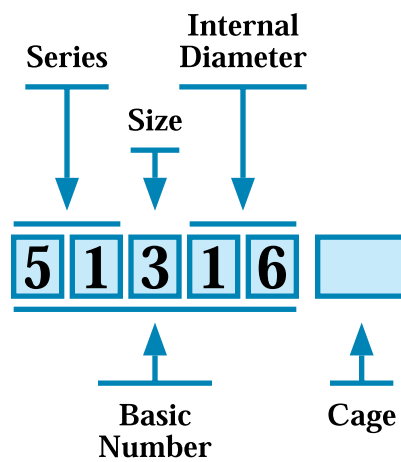

1. SERIES & SIZE

- 51, 53*: Single direction thrust ball bearing
- 52, 54*: Double direction thrust ball bearing
- 56: Angular contact thrust ball bearing
- 29: Spherical thrust roller bearing
- 29: Single direction thrust ball bearing
- 9: Single direction thrust ball bearing

2. CAGE

- No Symbol: Standard cage
- J: Pressed steel cage
- L1: Machined brass cage
- T2: Plastic cage, nylon or teflon

* Self-aligning outside diameter



Units: INCHES
Millimeters

SINGLE DIRECTION THRUST BALL BEARINGS

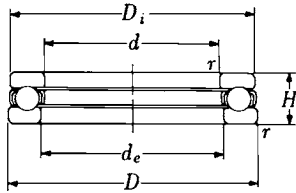

Bearing No.	d	d _e	D _i	D	H	r	Basic Load Ratings (lbs)		Weight (lbs)
							Dynamic C	Static C _o	
51100	.3937 10	.433 11	.945 24	.9449 24	.3543 9	.012 0.3	2,250	3,150	.046
51101	.4724 12	.512 13	1.024 26	1.0236 26	.3543 9	.012 0.3	2,320	3,450	.051
51102	.5906 15	.630 16	1.102 28	1.1024 28	.3543 9	.012 0.3	2,370	3,750	.053
51103	.6693 17	.709 18	1.181 30	1.1811 30	.3543 9	.012 0.3	2,430	4,100	.057
51104	.7874 20	.827 21	1.378 35	1.3780 35	.3937 10	.012 0.3	3,200	5,550	.088
51105	.9843 25	1.024 26	1.654 42	1.6535 42	.4331 11	.024 0.6	4,400	8,350	.132
51106	1.1811 30	1.260 32	1.850 47	1.8504 47	.4331 11	.024 0.6	4,600	9,500	.152
51107	1.3780 35	1.457 37	2.047 52	2.0472 52	.4724 12	.024 0.6	4,600	10,000	.187
51108	1.5748 40	1.654 42	2.362 60	2.3622 60	.5118 13	.024 0.6	6,050	14,100	.276
51109	1.7717 45	1.850 47	2.559 65	2.5591 65	.5512 14	.024 0.6	6,250	15,500	.326
51110	1.9685 50	2.047 52	2.756 70	2.7559 70	.5512 14	.024 0.6	6,450	17,000	.355
51111	2.1654 55	2.244 57	3.071 78	3.0709 78	.6299 16	.024 0.6	7,800	20,900	.498
51112	2.3622 60	2.441 62	3.346 85	3.3465 85	.6693 17	.039 1.0	9,300	25,300	.653
51113	2.5591 65	2.638 67	3.543 90	3.5433 90	.7087 18	.039 1.0	9,400	26,400	.745
51114	2.7559 70	2.835 72	3.740 95	3.7402 95	.7087 18	.039 1.0	9,700	28,500	.785
51115	2.9528 75	3.031 77	3.937 100	3.9370 100	.7480 19	.039 1.0	10,000	30,500	.880
51116	3.1496 80	3.228 82	4.134 105	4.1339 105	.7480 19	.039 1.0	10,000	31,500	.930
51117	3.3465 85	3.425 87	4.331 110	4.3307 110	.7480 19	.039 1.0	10,300	34,000	.979
51118	3.5433 90	3.622 92	4.724 120	4.7244 120	.8661 22	.039 1.0	13,400	42,500	1.51
51120	3.9370 100	4.016 102	5.315 135	5.3150 135	.9843 25	.039 1.0	19,100	60,500	2.16
51122	4.3307 110	4.409 112	5.709 145	5.7087 145	.9843 25	.039 1.0	19,600	64,500	2.36
51124	4.7244 120	4.803 122	6.102 155	6.1024 155	.9843 25	.039 1.0	20,000	69,000	2.45
51126	5.1181 130	5.197 132	6.693 170	6.6929 170	1.1811 30	.039 1.0	23,300	79,000	3.81
51128X	5.5113 140	5.591 142	7.008 178	7.0866 180	1.2205 31	.039 1.0	24,000	84,000	4.11
51130X	5.9055 150	5.984 152	7.402 188	7.4803 190	1.2205 31	.039 1.0	24,600	90,500	4.71
51132X	6.2992 160	6.378 162	7.795 198	7.8740 200	1.2205 31	.039 1.0	25,100	96,000	5.04
51134X	6.6929 170	6.772 172	8.386 213	8.4646 215	1.3386 34	.059 1.5	30,000	115,000	6.46
51136X	7.0866 180	7.205 183	8.740 222	8.8583 225	1.3386 34	.059 1.5	30,500	119,000	6.65
51138X	7.4803 190	7.598 193	9.331 237	9.4488 240	1.4567 37	.059 1.5	38,500	148,000	8.64
51140X	7.8740 200	7.992 203	9.724 247	9.8425 250	1.4567 37	.059 1.5	38,500	152,000	9.05
51144X	8.6614 220	8.780 223	10.512 267	10.6299 270	1.4567 37	.059 1.5	40,000	166,000	9.88
51148X	9.4488 240	9.567 243	11.693 297	11.8110 300	1.7717 45	.079 2.0	51,000	210,000	15.8
51152X	10.2362 260	10.354 263	12.480 317	12.5984 320	1.7717 45	.079 2.0	52,000	222,000	17.0

SINGLE DIRECTION THRUST BALL BEARINGS

Units: **INCHES**
Millimeters



Bearing No.	<i>d</i>	<i>d_e</i>	<i>D</i>	<i>H</i>	<i>r</i>	Basic Load Ratings (lbs)		Weight (lbs)
						<i>Dynamic C</i>	<i>Static C_o</i>	
51200	.3937 10	.472 12	1.0236 26	.4331 11	.024 0.6	2,850	3,850	.066
51201	.4724 12	.551 14	1.1024 28	.4331 11	.024 0.6	2,960	4,250	.075
51202	.5906 15	.669 17	1.2598 32	.4724 12	.024 0.6	3,750	5,600	.101
51203	.6693 17	.748 19	1.3780 35	.4724 12	.024 0.6	3,850	6,150	.119
51204	.7874 20	.866 22	1.5748 40	.5512 14	.024 0.6	5,000	8,500	.179
51205	.9843 25	1.063 27	1.8504 47	.5906 15	.024 0.6	6,250	11,300	.245
51206	1.1811 30	1.260 32	2.0472 52	.6299 16	.024 0.6	6,600	13,100	.306
51207	1.3780 35	1.457 37	2.4409 62	.7087 18	.039 1.0	8,800	17,600	.474
51208	1.5748 40	1.654 42	2.6772 68	.7480 19	.039 1.0	10,600	22,100	.608
51209	1.7717 45	1.850 47	2.8740 73	.7874 20	.039 1.0	10,700	23,600	.699
51210	1.9685 50	2.047 52	3.0709 78	.8661 22	.039 1.0	10,900	25,100	.833
51211	2.1654 55	2.244 57	3.5433 90	.9843 25	.039 1.0	15,600	35,500	1.34
51212	2.3622 60	2.441 62	3.7402 95	1.0236 26	.039 1.0	16,500	40,000	1.49
51213	2.5591 65	2.638 67	3.9370 100	1.0630 27	.039 1.0	16,800	42,500	1.69
51214	2.7559 70	2.835 72	4.1339 105	1.0630 27	.039 1.0	17,100	44,500	1.75
51215	2.9528 75	3.031 77	4.3307 110	1.0630 27	.039 1.0	17,400	47,000	1.93
51216	3.1496 80	3.228 82	4.5276 115	1.1024 28	.039 1.0	17,700	49,000	2.02
51217	3.3465 85	3.465 88	4.9213 125	1.2205 31	.039 1.0	21,400	59,500	2.76
51218	3.5433 90	3.661 93	5.3150 135	1.3780 35	.059 1.5	26,200	73,000	3.75
51220	3.9370 100	4.055 103	5.9055 150	1.4961 38	.059 1.5	33,000	92,000	5.05
51222	4.3307 110	4.449 113	6.2992 160	1.4961 38	.059 1.5	34,500	101,000	5.42
51224	4.7244 120	4.843 123	6.6929 170	1.5354 39	.059 1.5	34,500	106,000	5.97
51226	5.1181 130	5.236 133	7.4803 190	1.7717 45	.079 2.0	43,000	127,000	9.03
51228	5.5118 140	5.630 143	7.8740 200	1.8110 46	.079 2.0	43,500	133,000	10.2

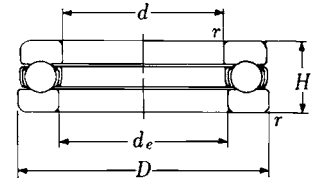



Units: INCHES
Millimeters

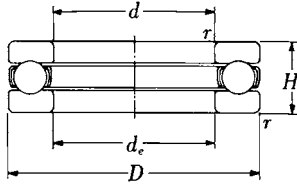

SINGLE DIRECTION THRUST BALL BEARINGS

Bearing No.	d	d _e	D	H	r	Basic Load Ratings (lbs)		Weight (lbs)
						Dynamic C	Static C _o	
2900	.3937 10	.402 10.2	1.0236 26	.4724 12	.024 0.6	2,850	3,850	.073
2901	.4724 12	.480 12.2	1.1024 28	.4724 12	.024 0.6	2,960	4,250	.082
2902	.5906 15	.598 15.2	1.2205 31	.4724 12	.024 0.6	3,200	5,150	.090
2903	.7087 18	.717 18.2	1.3780 35	.4724 12	.024 0.6	3,250	5,550	.099
2904 1/2	.7874 20	.795 20.2	1.4567 37	.4724 12	.024 0.6	3,350	6,000	.121
2904	.8661 22	.874 22.2	1.6535 42	.5512 14	.024 0.6	4,250	7,800	.185
2905	.9843 25	.992 25.2	1.7717 45	.5512 14	.024 0.6	4,350	8,350	.207
2906	1.1811 30	1.189 30.2	1.9685 50	.5512 14	.024 0.6	4,550	9,500	.238
2907	1.3780 35	1.386 35.2	2.1654 55	.6299 16	.024 0.6	6,700	14,000	.304
2908	1.5748 40	1.583 40.2	2.3622 60	.6299 16	.024 0.6	7,050	15,700	.340
2909	1.7717 45	1.780 45.2	2.6772 68	.6299 16	.024 0.6	7,250	17,400	.441
2910	1.9685 50	1.976 50.2	2.9134 74	.7087 18	.024 0.6	8,650	21,100	.567
2911	2.1654 55	2.173 55.2	3.0709 78	.7087 18	.024 0.6	9,000	23,200	.582
2912	2.3622 60	2.370 60.2	3.2283 82	.7087 18	.024 0.6	9,100	24,300	.595
2913	2.5591 65	2.567 65.2	3.5433 90	.7874 20	.024 0.6	10,600	28,900	.820
2914	2.7559 70	2.764 70.2	3.7402 95	.7874 20	.024 0.6	11,000	31,500	.873
2915	2.9528 75	2.961 75.2	3.9370 100	.7874 20	.024 0.6	11,400	34,000	.926
2916	3.1496 80	3.157 80.2	4.3307 110	.8661 22	.024 0.6	12,900	38,500	1.31
2917	3.3465 85	3.354 85.2	4.5276 115	.8661 22	.024 0.6	13,300	41,500	1.40
2918	3.5433 90	3.551 90.2	4.7244 120	.8661 22	.024 0.6	13,400	42,500	1.47
2919	3.7402 95	3.748 95.2	5.1181 130	.9843 25	.024 0.6	12,500	40,000	2.09
2920	3.9370 100	3.945 100.2	5.3150 135	.9843 25	.024 0.6	19,100	60,500	2.17
2922	4.3307 110	4.339 110.2	5.7087 145	.9843 25	.024 0.6	19,600	64,500	2.36
2924	4.7244 120	4.732 120.2	6.2992 160	1.0630 27	.024 0.6	22,100	75,500	3.20

SPHERICAL ROLLER THRUST BEARINGS

Units: **INCHES**
Millimeters

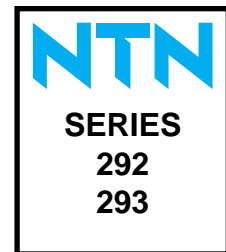

Bearing No.	<i>d</i>	<i>D</i>	<i>H</i>	<i>D</i> ₁	<i>d</i> ₁	<i>h</i> ₁	<i>h</i> ₂	<i>A</i>	<i>r</i>	Basic Load Ratings (lbs)		Weight (lbs)
										Dynamic <i>C</i>	Static <i>C</i> ₀	
29230	5.9055 150	8.4646 215	1.5354 39	8.1890 208	7.01 178	.551 14	.748 19.0	3.228 82	.079 2.0	76,500	300,000	9.85
29232	6.2992 160	8.8583 225	1.5354 39	8.6220 219	7.40 188	.551 14	.748 19.0	3.386 86	.079 2.0	80,500	325,000	10.4
29234	6.6929 170	9.4488 240	1.6535 42	9.1732 233	7.80 198	.591 15	.787 20.0	3.622 92	.079 2.0	95,500	395,000	12.8
29236	7.0866 180	9.8425 250	1.6535 42	9.5669 243	8.19 208	.591 15	.787 20.0	3.819 97	.079 2.0	101,000	430,000	13.5
29238	7.4803 190	10.6299 270	1.8898 48	10.3150 262	8.78 223	.591 15	.945 24.0	4.094 104	.098 2.5	119,000	500,000	18.8
29240	7.8740 200	11.0236 280	1.8898 48	10.6693 271	9.29 236	.591 15	.945 24.0	4.252 108	.098 2.5	120,000	515,000	19.6
29244	8.6614 220	11.8110 300	1.8898 48	11.4961 292	10.00 254	.591 15	.945 24.0	4.606 117	.098 2.5	125,000	560,000	22.0
29248	9.4488 240	13.3858 340	2.3622 60	12.9921 330	11.14 330	.748 19	1.181 30.0	5.118 130	.098 2.5	185,000	810,000	36.8
29252	10.2362 260	14.1732 360	2.3622 60	13.7795 350	11.89 302	.748 19	1.181 30.0	5.472 139	.098 2.5	195,000	885,000	40.8
29256	11.0236 280	14.9606 380	2.3622 60	14.5669 370	12.72 323	.748 19	1.181 30.0	5.906 150	.098 2.5	197,000	910,000	43.0
29317	3.3465 85	5.9055 150	1.5354 39	5.6496 143.5	4.49 114	.512 13	.748 19.0	1.969 50	.079 2.0	59,500	185,000	6.33
29218	3.5433 90	6.1024 155	1.5354 39	5.8465 148.5	4.61 117	.512 13	.748 19.0	2.047 52	.079 2.0	64,000	206,000	6.75
29220	3.9370 100	6.6929 170	1.6535 42	6.4173 163	5.08 129	.551 14	.819 20.8	2.283 58	.079 2.0	78,000	260,000	8.62
29322	4.3307 110	7.4803 190	1.8898 48	7.1654 182	5.63 143	.630 16	.906 23.0	2.520 64	.098 2.5	99,500	335,000	12.3
29224	4.7244 120	8.2677 210	2.1260 54	7.8740 200	6.26 159	.709 18	1.024 26.0	2.756 70	.098 2.5	120,000	400,000	16.9
29226	5.1181 130	8.8583 225	2.2835 58	8.4646 215	6.73 171	.748 19	1.102 28.0	2.992 76	.098 2.5	138,000	475,000	20.8
29328	5.5118 140	9.4488 240	2.3622 60	9.0551 230	7.20 183	.787 20	1.142 29.0	3.228 82	.098 2.5	154,000	530,000	24.5
29230	5.9055 150	9.8425 250	2.3622 60	9.4488 240	7.64 194	.787 20	1.142 29.0	3.425 87	.098 2.5	151,000	535,000	25.6
29232	6.2992 160	10.6299 270	2.6378 67	10.2362 260	8.19 208	.906 23	1.260 32.0	3.622 92	.118 3.0	185,000	645,000	34.0
29334	6.6929 170	11.0236 280	2.6378 67	10.6299 270	8.50 216	.906 23	1.260 32.0	3.780 96	.118 3.0	192,000	685,000	35.7
29236	7.0866 180	11.8110 300	2.8740 73	11.4173 290	9.13 232	.984 25	1.378 35.0	4.055 103	.118 3.0	224,000	805,000	45.6
29238	7.4803 190	12.5984 320	3.0709 78	12.1260 308	9.69 246	1.063 27	1.496 38.0	4.331 110	.157 4.0	258,000	955,000	55.3
29340	7.8740 200	13.3858 340	3.3465 85	12.7953 325	10.28 261	1.142 29	1.614 41.0	4.567 116	.157 4.0	288,000	1,030,000	68.8
29244	8.6614 220	14.1732 360	3.3465 85	13.5827 345	11.02 280	1.142 29	1.614 41.0	4.921 125	.157 4.0	310,000	1,170,000	73.4
29248	9.4488 240	14.9606 380	3.3465 85	14.3701 365	11.81 300	1.142 29	1.614 41.0	5.315 135	.157 4.0	310,000	1,180,000	78.3
29352	10.2362 260	16.5354 420	3.7402 95	15.9449 405	12.95 329	1.260 32	1.772 45.0	5.827 148	.197 5.0	385,000	1,530,000	115
29256	11.0236 280	17.3228 440	3.7402 95	16.6535 423	13.70 348	1.260 32	1.811 46.0	6.220 158	.197 5.0	405,000	1,630,000	120

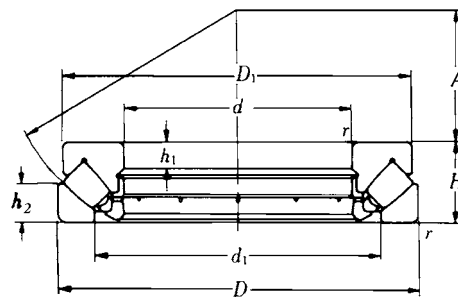



Units: INCHES
Millimeters

SPHERICAL ROLLER THRUST BEARINGS

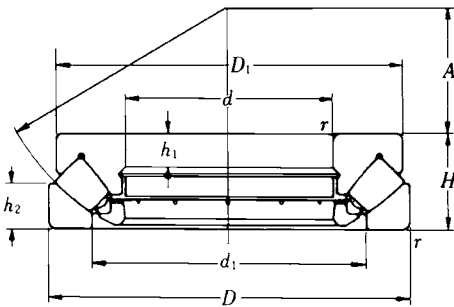

Bearing No.	d	D	H	D_1	d_1	h_1	h_2	A	r	Basic Load Ratings (lbs)		Weight (lbs)
										Dynamic C	Static C_o	
29412	2.3622	5.1181	1.6535	4.8425	3.50	.591	.787	1.496	.079	63,500	181,000	5.75
	60	130	42	123	89	15	20	38	2.0			
29413	2.5591	5.5118	1.7717	5.2362	3.78	.630	.827	1.654	.098	74,000	212,000	7.36
	65	140	45	133	96	16	21	42	2.5			
29414	2.7559	5.9055	1.8898	5.5906	4.06	.669	.906	1.732	.098	82,000	234,000	8.95
	70	150	48	142	103	17	23	44	2.5			
29415	2.9528	6.2992	2.0079	5.9843	4.29	.709	.945	1.850	.098	94,000	268,000	10.5
	75	160	51	152	109	18	24	47	2.5			
29416	3.1496	6.6929	2.1260	6.3780	4.61	.748	1.024	1.969	.098	103,000	310,000	13.0
	80	170	54	162	117	19	26	50	2.5			
29417	3.3465	7.0866	2.2835	6.6929	4.92	.827	1.102	2.126	.098	110,000	335,000	15.5
	85	180	58	170	125	21	28	54	2.5			
29418	3.5433	7.4803	2.3622	7.0866	5.20	.866	1.142	2.205	.098	123,000	380,000	18.0
	90	190	60	180	132	22	29	56	2.5			
29420	3.9370	8.2677	2.6378	7.8740	5.75	.945	1.260	2.441	.118	154,000	480,000	24.7
	100	210	67	200	146	24	32	62	3.0			
29422	4.3307	9.0551	2.8740	8.6614	6.38	1.024	1.378	2.717	.118	190,000	590,000	32.4
	110	230	73	220	162	26	35	69	3.0			
29424	4.7244	9.8425	3.0709	9.2913	6.85	1.142	1.457	2.913	.157	219,000	690,000	40.1
	120	250	78	236	174	29	37	74	4.0			
29426	5.1181	10.6299	3.3465	10.0394	7.44	1.220	1.614	3.189	.157	242,000	795,000	50.3
	130	270	85	255	189	31	41	81	4.0			
29428	5.5118	11.0236	3.3465	10.5512	7.83	1.220	1.614	3.386	.157	251,000	845,000	54.2
	140	280	85	268	199	31	41	86	4.0			
29430	5.9055	11.8110	3.5433	11.2205	8.43	1.260	1.732	3.622	.157	288,000	980,000	65.9
	150	300	90	285	214	32	44	92	4.0			
29432	6.2992	12.5984	3.7402	12.0472	9.02	1.339	1.772	3.898	.197	335,000	1,160,000	79.8
	160	320	95	306	229	34	45	99	5.0			
29434	6.6929	13.3858	4.0551	12.7559	9.57	1.457	1.969	4.094	.197	370,000	1,300,000	97.7
	170	340	103	324	243	37	50	104	5.0			
29436	7.0866	14.1732	4.2913	13.4646	10.04	1.535	2.047	4.331	.197	415,000	1,400,000	116
	180	360	109	342	255	39	52	110	5.0			
29438	7.4803	14.9606	4.5276	14.1732	10.67	1.614	2.165	4.606	.197	450,000	1,530,000	134
	190	380	115	360	271	41	55	117	5.0			
29440	7.8740	15.7480	4.8031	14.9606	11.26	1.693	2.323	4.803	.197	500,000	1,720,000	159
	200	400	122	380	286	43	59	122	5.0			
29444	8.6614	16.5354	4.8031	15.7480	12.13	1.693	2.283	5.197	.236	515,000	1,820,000	165
	220	420	122	400	308	43	58	132	6.0			
29448	9.4488	17.3228	4.8031	16.5354	12.83	1.693	2.323	5.591	.236	540,000	1,950,000	176
	240	440	122	420	326	43	59	142	6.0			
29452	10.2362	18.8976	5.1969	18.1102	14.06	1.890	2.520	6.063	.236	615,000	2,250,000	229
	260	480	132	460	357	48	64	154	6.0			
29456	11.0236	20.4724	5.7087	19.4882	15.24	2.047	2.677	6.535	.236	750,000	2,790,000	295
	280	520	145	495	387	52	68	166	6.0			

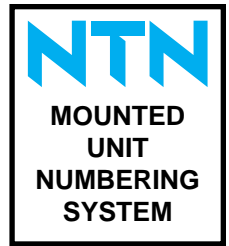

Metric Series

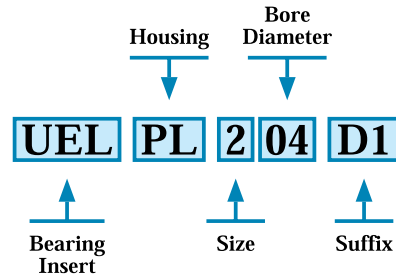

Ultra Class Series

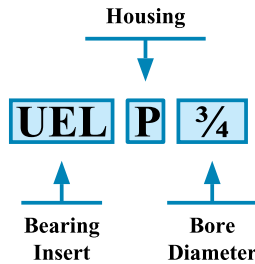

Inch Series

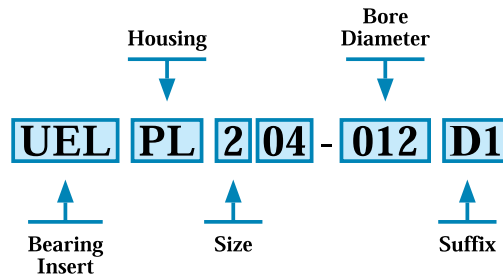

1. PREFIX

F:	Stainless
A:	Lube on non-locking mechanism side

2. BEARING INSERTS*

AEL:	Narrow inner ring, locking collar
AR:	Narrow inner ring, set screw type
AS:	Narrow inner ring, set screw type
JEL:	Narrow inner ring, locking collar
REL:	Wide inner ring, locking collar
UR:	Wide inner ring, set screw type
UC:	Wide inner ring, set screw type, with flinger
UEL:	Wide inner ring, locking collar, with flinger
UK:	Tapered bore, with flinger

3. HOUSINGS

F:	Flanged unit, cast - 4-bolt square housing
FA:	Flanged unit, cast - rhombus housing
FC:	Flanged piloted unit, cast - round housing
FD:	Flanged unit, cast - 2-bolt housing
FH:	Flanged unit, cast housing
FL:	Flanged unit, cast - 2-bolt housing
FS:	Flanged piloted unit, cast - 4-bolt square housing
FU:	Flanged unit, cast - 4-bolt square housing
PF:	Flanged unit, pressed steel - 3-bolt round housing
PFL:	Flanged unit, pressed steel - 2-bolt housing
RPF:	Flanged unit, pressed steel with rubber ring - 3-bolt round housing
HP:	Pillow Block, cast housing, high center height
P:	Pillow Block, cast housing
PL:	Pillow Block, cast housing, low center height

PP:	Pillow Block, pressed steel housing
RPP:	Pillow Block, pressed steel housing with rubber ring
UP:	Pillow Block, cast housing
C:	Cylindrical cartridge unit
HB:	Hanger unit, cast housing
PT:	Mini stretcher
T:	Take-up unit, cast housing

4. SIZE

2:	Light
X:	Medium
3:	Heavy

5. SUFFIX

D1:	Relube type
W3:	Cup Point Set Screw
N:	Snap Ring Groove
NR:	Snap Ring and Groove
R:	Meets ISO Series
HT1D1:	Heat stabilized for up to 284° F
HT2D1:	Heat stabilized for up to 392° F

* To order a bearing with a cylindrical O.D., add S to the part number (example: JELS).



**MOUNTED
UNIT
SELECTION
MATRIX**

Bearing Insert		Housing		High Base Pillow Block		Low Base Pillow Block		2-Bolt Flange		4-Bolt Square Flange		Pressed Steel Pillow Block		Pressed Steel Flanges		
		Page		Page		Page		Page		Page		Page		Page		
Ultra-Class	Setscrew Type	A-UC2	204	UCP-	135	UCPL-	136	UCFLU-	144	UCFU-	149					
		A-UCX	206	UCPX-	137			UCFLUX-	145	UCFUX-	150					
		A-AR2	208	ARP-	138	ARPL-	139	ARFLU-	146	ARFU-	152					
	Eccentric Locking Collar	A-UCL2	211	UCLP-	140	UCLPL-	141	UCLFLU-	147	UCLFU-	151					
		A-JEL2	214	JELP-	142	JELPL-	143	JELFLU-	148	JELFU-	153					
	Standard ISO Series	Setscrew Type	UC2	204	UCP2	156	UCPL2-	158	UCFL2	174	UCF2	191				
UC3			205	UCP3	159			UCFL3	175	UCF3	193					
UCX			206	UCPX	160			UCFLX	176	UCFX	195					
AS2			207			ASPL2	162	ASFD2	182		ASPP2	163	ASPF2	188	ASPFL2	185
Eccentric Locking Collar		UEL2	211	UELP2	164	UELPL2	165	UELFL2	177	UELF2	197					
		UEL3	212	UELP3	166			UELFL3	178	UELF3	198					
		AEL2	213	AELP2	168	AELPL2	169	AELFL2	180		AELPP2	170	AELPF2	189	AELPFL2	186
		JEL2	214			JELPL2	167	JELFL2	181				JELPF2	190	JELPFL2	187
Adapter Type		UK2	216	UKP2	171					UKF2	200					
Other Bearings				UCS3	210	AELS2	213	ASS2	207	UCS2	209	REL2	215	Farm Implement Bearings	222	

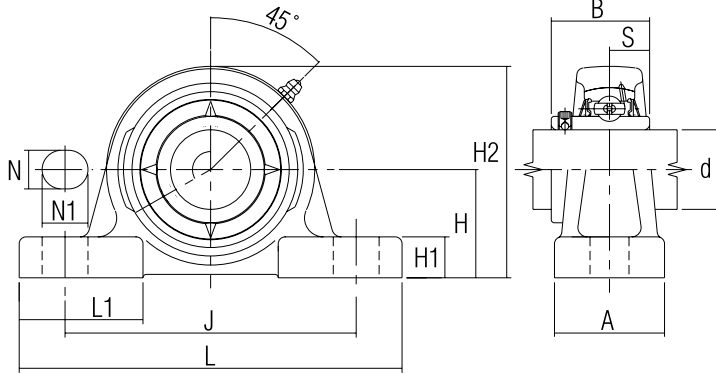

Units: **Millimeters**
INCHES

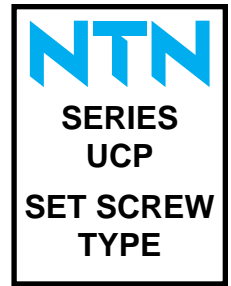

PILLOW BLOCKS - ULTRA CLASS

Part Number	Nominal Dimensions												Bolt Size	Lube Hole of Housing	Insert Bearing Number	Housing Number
	d	H	L	J	A	N	N1	H1	H2	L1	B	S				
UCP-1/2	0.5000	30.2	127	92.1	38	11.1	22.2	14	62	42	27.4	11.5	3/8	1/4-28UNF	A-UC201X-008D1 A-UC202X-009D1 A-UC202X-010D1 A-UC203X-011D1	P201D1V50
UCP-9/16	0.5625	1 3/16	5	3 5/8	1 1/2	7/16	7/8	9/16	2 7/16	1 21/32	1.0787	0.453				
UCP-5/8	0.6250															
UCP-11/16	0.6875															
UCP-3/4	0.7500	33.3	127	96	38	11.1	19.8	14	65	42	31	12.7	3/8	1/4-28UNF	A-UC204-012D1	P204D1V50
		1 5/16	5	3 25/32	1 1/2	7/16	25/32	9/16	2 9/16	1 21/32	1.2205	0.500				
UCP-13/16	0.8125	36.5	140	104.8	38	11.1	20.6	15	71	42	34.1	14.3	3/8	1/8-27NPT	A-UC205-013D1 A-UC205-014D1 A-UC205-015D1 A-UC205-100D1	P205D1V50
UCP-7/8	0.8750	1 7/16	5 1/2	4 1/8	1 1/2	7/16	13/16	19/32	2 25/32	1 21/32	1.3425	0.563				
UCP-15/16	0.9375															
UCP-1	1.0000															
UCP-1 1/16	1.0625	42.9	165	117.5	48	14.3	23.8	17	83	54	38.1	15.9	1/2	1/8-27NPT	A-UC206-101D1 A-UC206-102D1 A-UC206-103D1 A-UC206-104D1	P206D1V50
UCP-1 1/8	1.1250	1 11/16	6 1/2	4 5/8	1 7/8	9/16	15/16	21/32	3 3/32	2 1/8	1.5000	0.626				
UCP-1 3/16	1.1875															
UCP-1 1/4S	1.2500															
UCP-1 1/4	1.2500	47.6	167	130.2	48	14.3	24.6	18	93	54	42.9	17.5	1/2	1/8-27NPT	A-UC207-104D1 A-UC207-105D1 A-UC207-106D1 A-UC207-107D1	P207D1V50
UCP-1 5/16	1.3125	1 7/8	6 9/16	5 1/8	1 7/8	9/16	31/32	23/32	3 21/32	2 1/8	1.6890	0.689				
UCP-1 3/8	1.3750															
UCP-1 7/16	1.4375															
UCP-1 1/2	1.5000	49.2	184	136.5	54	14.3	26.2	18	98	52	49.2	19	1/2	1/8-27NPT	A-UC208-108D1 A-UC208-109D1	P208D1V50
UCP-1 9/16	1.5625	1 15/16	7 1/4	5 3/8	2 1/8	9/16	1 1/32	23/32	3 27/32	2 1/16	1.9370	0.748				
UCP-1 5/8	1.6250	54	190	149.2	54	14.3	28.6	20	106	60	49.2	19	1/2	1/8-27NPT	A-UC209-110D1 A-UC209-111D1 A-UC209-112D1	P209D1V50
UCP-1 11/16	1.6875	2 1/8	7 15/32	5 7/8	2 1/8	9/16	1 1/8	25/32	4 3/16	2 3/8	1.9370	0.748				
UCP-1 3/4	1.7500															
UCP-1 13/16	1.8125	57.2	206	158	60	17.5	23.8	21	114	65	51.6	19	5/8	1/8-27NPT	A-UC210-113D1 A-UC210-114D1 A-UC210-115D1 A-UC210-200D1	P210D1V50
UCP-1 7/8	1.8750	2 1/4	8 1/8	6 7/32	2 3/8	11/16	15/16	13/16	4 1/2	2 9/16	2.0315	0.748				
UCP-1 15/16	1.9375															
UCP-2S	2.0000															
UCP-2	2.0000	63.5	219	176.2	60	18.3	29.4	23	126	65	55.6	22.2	5/8	1/8-27NPT	A-UC211-200D1 A-UC211-201D1 A-UC211-202D1 A-UC211-203D1	P211D1V50
UCP-2 1/16	2.0625	2 1/2	8 5/8	6 15/16	2 3/8	23/32	1 5/32	29/32	4 3/32	2 9/16	2.1890	0.874				
UCP-2 1/8	2.1250															
UCP-2 3/16	2.1875															
UCP-2 1/4	2.2500	69.8	241	188.1	70	18.3	29.4	25	138	70	65.1	25.4	5/8	1/8-27NPT	A-UC212-204D1 A-UC212-205D1 A-UC212-206D1 A-UC212-207D1	P212D1V50
UCP-2 5/16	2.3125	2 3/4	9 1/2	7 13/32	2 3/4	23/32	1 5/32	31/32	5 7/16	2 3/4	2.5630	1.000				
UCP-2 3/8	2.3750															
UCP-2 7/16	2.4375															
UCP-2 1/2	2.5	76.2	265	203	70	25	28	27	151	77	65.1	25.4	3/4	1/8-27NPT	A-UC213-208D1 A-UC213-209D1	P213D1V50
UCP-2 9/16	2.5625	3	10 7/16	8	2 3/4	31/32	1 3/32	1 1/16	5 15/16	3 1/32	2.563	1				
UCP-2 5/8 R	2.625	79.4	266	210	72	25	28	27	157	77	74.6	30.2	3/4	1/8-27NPT	A-UC214-210D1 A-UC214-211D1 A-UC214-213D1	P214D1V50
UCP-2 11/16 R	2.6875	3 1/8	10 15/32	8 9/32	2 27/32	31/32	1 3/32	1 1/16	6 3/16	3 1/32	2.937	1.189				
UCP-2 3/4 R	2.75															
UCP-2 13/16	2.8125	82.6	275	215.9	74	22.2	31.8	28	163	80	77.8	33.3	3/4	1/8-27NPT	A-UC215-213D1 A-UC215-214D1 A-UC215-215D1 A-UC215-300D1	P215D1V50
UCP-2 7/8	2.8750	3 1/4	10 13/16	8 1/2	2 29/32	7/8	1 1/4	1 3/32	6 13/32	3 5/32	3.0630	1.311				
UCP-2 15/16	2.9375															
UCP-3	3.0000															

Note: Metric Sizes available. The production and shipment of black oxide coated inserts will be introduced as a rolling change. This is denoted with an M at the end of the current part number. Please consult NTN for availability.



Units: Millimeters
INCHES

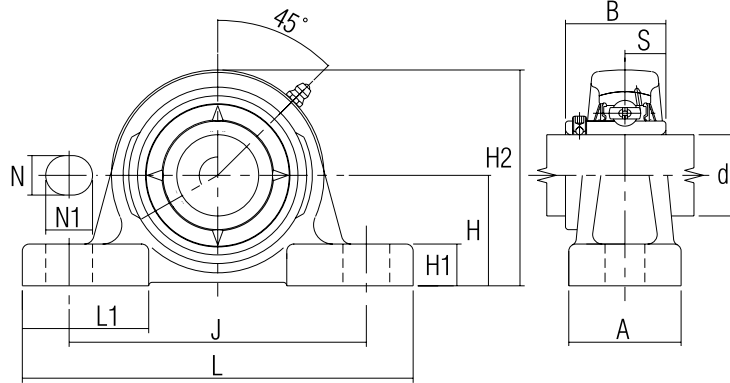

PILLOW BLOCKS - ULTRA CLASS

Part Number	Nominal Dimensions												Bolt Size	Lube Hole of Housing	Insert Bearing Number	Housing Number		
	d	H	L	J	A	N	N1	H1	H2	L1	B	S						
UCPL-1/2	0.5000	27	121	92.1	34.9	11.1	22.2	13	54	40	27.4	11.5	3/8	1/4-28UNF	A-UC201X-008D1	PL201D1V50		
UCPL-9/16	0.5625	1 1/16	4 3/4	3 5/8	1 3/8	7/16	7/8	1/2	2 1/8	1 9/16	1.0787	0.453			A-UC202X-009D1			
UCPL-5/8	0.6250														A-UC202X010D1			
UCPL-11/16	0.6875														A-UC203X-011D1			
UCPL-3/4	0.7500	31.75	127	96	38.1	11.1	19.8	14	64	42	31	12.7	3/8	1/4-28UNF	A-UC204-012D1	PL204D1V50		
		1 1/4	5	3 25/32	1 1/2	7/16	25/32	9/16	2 17/32	1 21/32	1.2205	0.500			A-UC205-013D1			
UCPL-13/16	0.8125	33.3	140	104.8	38.1	11.1	20.6	15	68	42	34.1	14.3			3/8		1/8-27NPT	A-UC205-014D1
UCPL-7/8	0.8750	1 3/16	5 1/2	4 1/8	1 1/2	7/16	13/16	19/32	2 11/16	1 21/32	1.3425	0.563						A-UC205-015D1
UCPL-15/16	0.9375												A-UC205-100D1					
UCPL-1	1.0000																	
UCPL-1 1/16	1.0625	39.7	165	117.5	47.6	14.3	23.8	17	80	54	38.1	15.9	1/2	1/8-27NPT	A-UC206-101D1	PL206D1V50		
UCPL-1 1/8	1.1250	1 9/16	6 1/2	4 5/8	1 7/8	9/16	15/16	21/32	3 5/32	2 1/8	1.5000	0.626			A-UC206-102D1			
UCPL-1 3/16	1.1875														A-UC206-103D1			
UCPL-1 1/4S	1.2500														A-UC206-104D1			
UCPL-1 1/4	1.2500	46	167	130.2	47.6	14.3	24.6	18	91	54	42.9	17.5	1/2	1/8-27NPT	A-UC207-104D1	PL207D1V50		
UCPL-1 5/16	1.3125	1 13/16	6 9/16	5 1/8	1 7/8	9/16	31/32	23/32	3 19/32	2 1/8	1.6890	0.689			A-UC207-105D1			
UCPL-1 3/8	1.3750														A-UC207-106D1			
UCPL-1 7/16	1.4375														A-UC207-107D1			
UCPL-1 1/2	1.5000	49.2	184	136.5	54	14.3	26.2	18	98	52	49.2	19	1/2	1/8-27NPT	A-UC208-108D1	P208D1V50		
UCPL-1 9/16	1.5625	1 15/16	7 1/4	5 3/8	2 1/8	9/16	1 1/32	23/32	3 27/32	2 1/16	1.9370	0.748			A-UC208-109D1			
UCPL-1 5/8	1.6250	54	190	149.2	54	14.3	28.6	20	104	60	49.2	19			1/2		1/8-27NPT	A-UC209-110D1
UCPL-1 11/16	1.6875	2 1/8	7 15/32	5 7/8	2 1/8	9/16	1 1/8	25/32	4 3/32	2 3/8	1.9370	0.748						A-UC209-111D1
UCPL-1 3/4	1.7500												A-UC209-112D1					
UCPL-1 13/16	1.8125	55.6	206	158	60.3	17.5	23.8	21	112	65	51.6	19	5/8	1/8-27NPT		A-UC210-113D1		
UCPL-1 7/8	1.8750	2 3/16	8 1/8	6 7/32	2 3/8	11/16	15/16	13/16	4 13/32	2 9/16	2.0315	0.748			A-UC210-114D1			
UCPL-1 15/16	1.9375														A-UC210-115D1			
UCPL-2S	2.0000														A-UC210-200D1			
UCPL-2	2.0000	61.9	219	176.2	60	18.3	29.4	23	124	65	55.6	22.2	5/8	1/8-27NPT	A-UC211-200D1	PL211D1V50		
UCPL-2 1/16	2.0625	2 7/16	8 5/8	6 15/16	2 3/8	23/32	1 5/32	29/32	4 7/8	2 9/16	2.1890	0.874			A-UC211-201D1			
UCPL-2 1/8	2.1250														A-UC211-202D1			
UCPL-2 3/16	2.1875														A-UC211-203D1			
UCPL-2 1/4	2.2500	68.3	241	188.1	69.9	17.5	29.4	25	136	70	65.1	25.4	5/8	1/8-27NPT	A-UC212-204D1	PL212D1V50		
UCPL-2 5/16	2.3125	2 11/16	9 1/2	7 13/32	2 3/4	11/16	1 5/32	31/32	5 11/32	2 3/4	2.5630	1.000			A-UC212-205D1			
UCPL-2 3/8	2.3750														A-UC212-206D1			
UCPL-2 7/16	2.4375														A-UC212-207D1			
UCPL-2 1/2	2.5000	76.2	265	203.2	70	25	28	27	151	77	65.1	25.4	3/4	1/8-27NPT	A-UC213-208D1	PL213D1V50		
UCPL-2 9/16	2.5625	3	10 7/16	8	2 3/4	31/32	1 3/32	1 1/16	5 15/16	3 1/32	2.563	1			A-UC213-209D1			
UCPL-2 5/8	2.6250	76.2	266	203.2	72.2	20.6	34.9	27	154	77	74.6	30.2			3/4		1/8-27NPT	A-UC214-210D1
UCPL-2 11/16	2.6875	3	10 15/32	8	2 27/32	13/16	1 3/8	1 1/16	6 1/16	3 1/32	2.9370	1.189						A-UC214-211D1
UCPL-2 3/4	3.7500												A-UC214-212D1					
UCPL-2 13/16	2.8125	84.1	305	241.3	73.8	22.2	31.8	28	165	80	77.8	33.3	3/4	1/8-27NPT		A-UC215-213D1		
UCPL-2 7/8	2.8750	3 5/16	12	9 1/2	2 29/32	7/8	1 1/4	1 3/32	6 1/2	3 5/32	3.0630	1.311			A-UC215-214D1			
UCPL-2 15/16	2.9375														A-UC215-215D1			
UCPL-3	3.0000														A-UC215-300D1			

Note: Metric Sizes available. The production and shipment of black oxide coated inserts will be introduced as a rolling change. This is denoted with an M at the end of the current part number. Please consult NTN for availability.

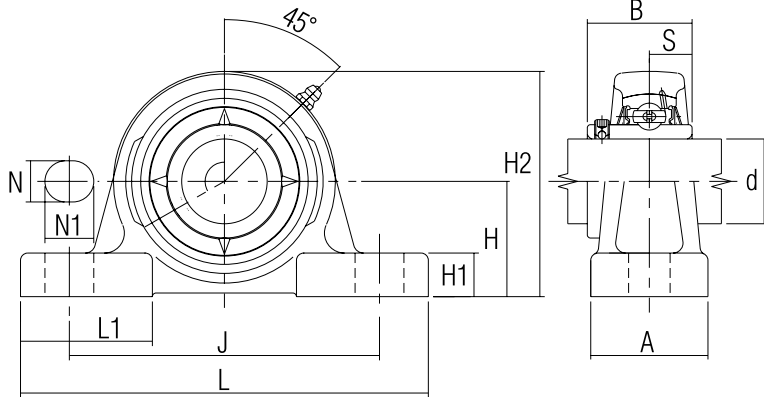

Units: Millimeters
INCHES

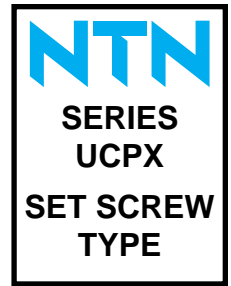

PILLOW BLOCKS - ULTRA CLASS

Part Number	Nominal Dimensions												Bolt Size	Lube Hole of Housing	Insert Bearing Number	Housing Number
	d	H	L	J	A	N	N1	H1	H2	L1	B	S				
UCPX-1 ³ / ₁₆	0.8125	42.9	165	117.5	48	14.3	23.8	17	83	54	38.1	15.9	1/2	1/8-27UNF	A-UCX05-013D1	P206D1V50
UCPX-7/8	0.8750	1 11/16	6 1/2	4 5/8	1 7/8	9/16	15/16	21/32	3 9/32	2 1/8	1.5000	0.626			A-UCX05-014D1	
UCPX-15/16	0.9375														A-UCX05-015D1	
UCPX-1	1.0000														A-UCX05-100D1	
UCPX-1 1/16	1.0625	47.6	167	130.2	48	14.3	24.6	18	93	54	42.9	17.5	1/2	1/8-27UNF	A-UCX06-101D1	P207D1V50
UCPX-1 1/8	1.1250	1 7/8	6 9/16	5 1/8	1 7/8	9/16	31/32	23/32	3 21/32	2 1/8	1.6890	0.689			A-UCX06-102D1	
UCPX-1 3/16	1.1875														A-UCX06-103D1	
UCPX-1 1/4	1.2500	54	179	136.5	48	14.3	26.2	23	105	60	49.2	19	1/2	1/8-27UNF	A-UC207-104D1	PX07D1V50
UCPX-1 5/16	1.3125	2 1/8	7 1/16	5 3/8	1 7/8	9/16	1 1/32	29/32	4 1/8	2 3/8	1.9370	0.748			A-UCX07-105D1	
UCPX-1 3/8	1.3750														A-UCX07-106D1	
UCPX-1 7/16	1.4375														A-UCX07-107D1	
UCPX-1 1/2	1.5000	54	190	149.2	54	14.3	28.6	20	106	60	49.2	19	1/2	1/8-27NPT	A-UCX08-108D1	P209D1V50
UCPX-1 9/16	1.5625	2 1/8	7 15/32	5 7/8	2 1/8	9/16	1 1/8	25/32	4 3/16	2 3/8	1.9370	0.748			A-UCX08-109D1	
UCPX-1 5/8	1.6250	57.2	206	158	60	17.5	23.8	21	114	65	51.6	19	5/8	1/8-27NPT	A-UCX09-110D1	P210D1V50
UCPX-1 11/16	1.6875	2 1/4	8 1/8	6 7/32	2 3/8	11/16	15/16	13/16	4 1/2	2 9/16	2.0315	0.748			A-UCX09-111D1	
UCPX-1 3/4	1.7500														A-UCX09-112D1	
UCPX-1 13/16	1.8125	63.5	219	176.2	60	18.3	29.4	23	126	65	55.6	22.2	5/8	1/8-27NPT	A-UC210-113D1	P211D1V50
UCPX-1 7/8	1.8750	2 1/2	8 5/8	6 15/16	2 3/8	23/32	1 9/32	29/32	4 31/32	2 9/16	2.1890	0.874			A-UCX10-114D1	
UCPX-1 15/16	1.9375														A-UCX10-115D1	
UCPX-2	2.0000														A-UC211-200D1	
UCPX-2 1/16	2.0625	69.8	241	188.1	70	18.3	29.4	25	138	70	65.1	25.4	5/8	1/8-27NPT	A-UCX11-201D1	P212D1V50
UCPX-2 1/8	2.1250	2 3/4	9 1/2	7 13/32	2 3/4	23/32	1 5/32	31/32	5 7/16	2 3/4	2.5630	1.000			A-UCX11-202D1	
UCPX-2 3/16	2.1875														A-UCX11-203D1	
UCPX-2 1/4	2.2500														A-UC212-204D1	
UCPX-2 7/16	2.4375	76.2	266	203.2	72	20.6	34.9	27	154	77	74.6	30.2	3/4	1/8-27NPT	A-UC214-207D1	PL214D1V50
UCPX-2 1/2	2.5000	3	10 15/32	8	2 27/32	13/16	1 3/8	1 1/16	6 1/16	3 1/32	2.9370	1.189			A-UCX13-208D1	
UCPX-2 9/16	2.5625														A-UCX13-209D1	
UCPX-2 5/8	2.6250	88.9	330	228.6	89	23.8	50.8	32	178	95	77.8	33.3	3/4	1/8-27NPT	A-UCX14-210D1	PX14D1V50
UCPX-2 11/16	2.6875	3 1/2	13	9	3 1/2	15/16	2	1 1/4	7	3 3/4	3.0630	1.311			A-UCX14-211D1	
UCPX-2 3/4	2.7500														A-UCX14-212D1	
UCPX-2 13/16	2.8125	88.9	330	228.9	89	23.8	50.8	32	178	95	82.6	33.3	3/4	1/8-27NPT	A-UCX15-213D1	PX15D1V50
UCPX-2 7/8	2.8750	3 1/2	13	9	3 1/2	15/16	2	1 1/4	7	3 3/4	3.2520	1.311			A-UCX15-214D1	
UCPX-2 15/16	2.9375														A-UCX15-215D1	
UCPX-3	3.0000														A-UCX15-300D1	
UCPX-3 3/16	2.1875	101.6	356	278.6	111	23.8	50.8	33	203	110	85.7	34.1	3/4	1/8-27NPT	A-UCX16-303D1	PX16D1V50
		4	14	10 31/32	4 3/8	15/16	2	1 5/16	8	4 11/32	3.3740	1.343				
UCPX-3 7/16	3.4375	101.6	356	278.6	111	23.8	50.8	33	203	110	104	42.9	3/4	1/8-27NPT	A-UCX18-307D1	PX18D1V50
UCPX-3 1/2	3.5000	4	14	10 31/32	4 3/8	15/16	2	1 5/16	8	4 11/32	4.0945	1.689			A-UCX18-308D1	

Note: Metric Sizes available. The production and shipment of black oxide coated inserts will be introduced as a rolling change. This is denoted with an M at the end of the current part number. Please consult NTN for availability.



Units: Millimeters
INCHES

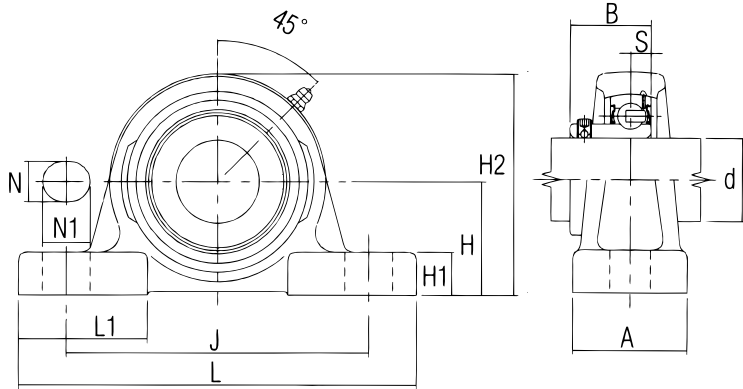

PILLOW BLOCKS - ULTRA CLASS HIGH BASE

Part Number	Nominal Dimensions												Bolt Size	Lube Hole of Housing	Insert Bearing Number	Housing Number	
	d	H	L	J	A	N	N1	H1	H2	L1	B	S					
ARP-1/2	0.5000		127	92.1	38.1	11.1	22.2	14		42				3/8	1/4-28UNF	A-AR201-008D1	P201D1V50
ARP-9/16	0.5625	1 3/16	5	3 5/8	1 1/2	7/16	7/8	9/16	2 7/16	1 21/32	0.8858	0.256				A-AR202-009D1	
ARP-5/8	0.6250															A-AR202-010D1	
ARP-11/16	0.6875															A-AR203-011D1	
ARP-3/4	0.7500	1 5/16	127	96	38.1	11.1	19.8	14	65	42				3/8	1/4-28UNF	A-AR204-012D1	P204D1V50
			5	3 25/32	1 1/2	7/16	25/32	9/16	2 9/16	1 21/32	1.0039	0.295					
ARP-13/16	0.8125	1 7/16	140	104.8	38.1	11.1	20.6	15		42				3/8	1/8-27NPT	A-AR205-013D1	P205D1V50
ARP-7/8	0.8750		5 1/2	4 1/8	1 1/2	7/16	13/16	15	2 25/32	1 21/32	1.0630	0.295				A-AR205-014D1	
ARP-15/16	0.9375															A-AR205-015D1	
ARP-1	1.0000															A-AR205-100D1	
ARP-1 1/16	1.0625	1 11/16	165	117.5	47.6	14.3	23.8	17		54				1/2	1/8-27NPT	A-AR206-101D1	P206D1V50
ARP-1 1/8	1.1250		6 1/2	4 5/8	1 7/8	9/16	15/16	17	3 9/32	2 1/8	1.1811	0.354				A-AR206-102D1	
ARP-1 3/16	1.1875															A-AR206-103D1	
ARP-1 1/4S	1.2500															A-AR206-104D1	
ARP-1 1/4	1.2500	1 7/8	167	130.2	47.6	14.3	24.6	18		54				1/2	1/8-27NPT	A-AR207-104D1	P207D1V50
ARP-1 5/16	1.3125		6 9/16	5 1/8	1 7/8	9/16	31/32	18	3 21/32	2 1/8	1.3780	0.374				A-AR207-105D1	
ARP-1 3/8	1.3750															A-AR207-106D1	
ARP-1 7/16	1.4375															A-AR207-107D1	
ARP-1 1/2	1.5000	1 15/16	184	136.5	54	14.3	26.2	18	98	52				1/2	1/8-27NPT	A-AR208-108D1	P208D1V50
ARP-1 9/16	1.5625		7 1/4	5 3/8	2 1/8	9/16	1 1/32	18	3 27/32	2 1/16	1.5748	0.433				A-AR208-109D1	
ARP-1 5/8	1.6250	2 1/8	190	149.2	54	14.3	28.6	20		60				1/2	1/8-27NPT	A-AR209-110D1	P209D1V50
ARP-1 11/16	1.6875		7 15/32	5 7/8	2 1/8	9/16	1 1/8	20	4 3/16	2 3/8	1.6339	0.433				A-AR209-111D1	
ARP-1 3/4	1.7500															A-AR209-112D1	
ARP-1 13/16	1.8125	2 1/4	206	158	60.3	17.5	23.8	21		65				5/8	1/8-27NPT	A-AR210-113D1	P210D1V50
ARP-1 7/8	1.8750		8 1/8	6 7/32	2 3/8	11/16	19/16	21	4 1/2	2 9/16	1.6929	0.433				A-AR210-114D1	
ARP-1 15/16	1.9375															A-AR210-115D1	
ARP-2S	2.0000															A-AR210-200D1	
ARP-2	2.0000	2 1/2	219	176.2	60	18.3	29.4	23		65				5/8	1/8-27NPT	A-AR211-200D1	P211D1V50
ARP-2 1/16	2.0625		8 5/8	6 15/16	2 3/8	23/32	1 5/32	23	4 31/32	2 9/16	1.6929	0.472				A-AR211-201D1	
ARP-2 1/8	2.1250															A-AR211-202D1	
ARP-2 3/16	2.1875															A-AR211-203D1	

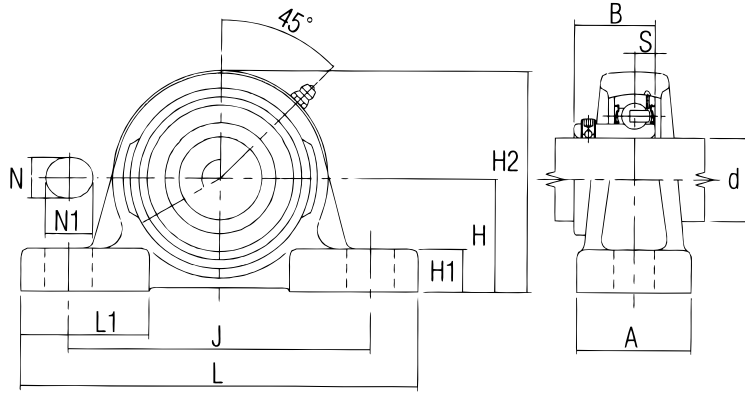

Units: Millimeters
INCHES

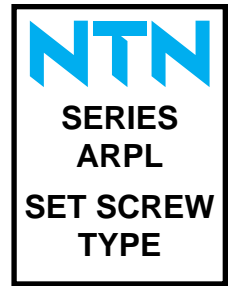

PILLOW BLOCKS - ULTRA CLASS LOW BASE

Part Number	Nominal Dimensions												Bolt Size	Lube Hole of Housing	Insert Bearing Number	Housing Number
	d	H	L	J	A	N	N1	H1	H2	L1	B	S				
ARPL-1/2	0.5000	27	121	92.1	34.9	11.1	22.2	13	54	40			3/8	1/4-28UNF	A-AR201-008D1	PL201D1V50
ARPL-9/16	0.5625	1 1/16	4 3/4	3 5/8	1 3/8	7/16	7/8	1/2	2 1/8	1 9/16	0.8858	0.256	3/8		A-AR202-009D1	
ARPL-5/8	0.6250														A-AR202-010D1	
ARPL-11/16	0.6875														A-AR203-011D1	
ARPL-3/4	0.7500	31.75	127	96	38.1	11.1	19.8	14	64	42			3/8	1/4-28UNF	A-AR204-012D1	PL204D1V50
		1 1/4	5	3 29/32	1 1/2	7/16	29/32	9/16	2 17/32	1 21/32	1.0039	0.295				
ARPL-13/16	0.8125	33.3	140	104.8	38.1	11.1	20.6	15	68	42			3/8	1/8-27NPT	A-AR205-013D1	PL205D1V50
ARPL-7/8	0.8750	1 5/16	5 1/2	4 1/8	1 1/2	7/16	13/16	19/32	2 11/16	1 21/32	1.0630	0.295			A-AR205-014D1	
ARPL-15/16	0.9375														A-AR205-015D1	
ARPL-1	1.0000														A-AR205-100D1	
ARPL-1 1/16	1.0625	39.7	165	117.5	47.6	14.3	23.8	17	80	54			1/2	1/8-27NPT	A-AR206-101D1	PL206D1V50
ARPL-1 1/8	1.1250	1 9/16	6 1/2	4 5/8	1 7/8	9/16	15/16	21/32	3 5/32	2 1/8	1.1811	0.354			A-AR206-102D1	
ARPL-1 3/16	1.1875														A-AR206-103D1	
ARPL-1 1/4	1.2500														A-AR206-104D1	
ARPL-1 1/4	1.2500	46	167	130.2	47.6	14.3	24.6	18	91	54			1/2	1/8-27NPT	A-AR207-104D1	PL207D1V50
ARPL-1 5/16	1.3125	1 13/16	6 9/16	5 1/8	1 7/8	9/16	31/32	23/32	3 19/32	2 1/8	1.3780	0.374			A-AR207-105D1	
ARPL-1 3/8	1.3750														A-AR207-106D1	
ARPL-1 7/16	1.4375														A-AR207-107D1	
ARPL-1 1/2	1.5000	49.2	184	136.5	54	14.3	26.2	18	98	52			1/2	1/8-27NPT	A-AR208-108D1	P208D1V50
ARPL-1 9/16	1.5625	1 15/16	7 1/4	5 3/8	2 1/8	9/16	1 1/32	23/32	3 27/32	2 1/16	1.5748	0.374			A-AR208-109D1	
ARPL-1 5/8	1.6250	52.4	190	149.2	54	14.3	28.6	20	104	60			1/2	1/8-27NPT	A-AR209-110D1	PL209D1V50
ARPL-1 11/16	1.6875	2 1/16	7 15/32	5 7/8	2 1/8	9/16	1 1/8	25/32	4 3/32	2 3/8	1.6339	0.433			A-AR209-111D1	
ARPL-1 3/4	1.7500														A-AR209-112D1	
ARPL-1 13/16	1.8125	55.6	206	158	60.3	17.5	23.8	21	112	65			5/8	1/8-27NPT	A-AR210-113D1	PL210D1V50
ARPL-1 7/8	1.8750	2 3/16	8 1/8	6 7/32	2 3/8	11/16	15/16	13/16	4 13/32	2 9/16	1.6929	0.433			A-AR210-114D1	
ARPL-1 15/16	1.9375														A-AR210-115D1	
ARPL-2S	2.0000														A-AR210-200D1	
ARPL-2	2.0000	61.9	219	176.2	60	18.3	29.4	23	124	65			5/8	1/8-27NPT	A-AR211-200D1	PL211D1V50
ARPL-2 1/16	2.0625	2 7/16	8 5/8	6 15/16	2 3/8	23/32	1 5/32	29/32	4 7/8	2 9/16	1.6929	0.472			A-AR211-201D1	
ARPL-2 1/8	2.1250														A-AR211-202D1	
ARPL-2 3/16	2.1875														A-AR211-203D1	

NTN
SERIES
UELP
ECCENTRIC
LOCKING
COLLAR
TYPE

Units: **Millimeters**
INCHES

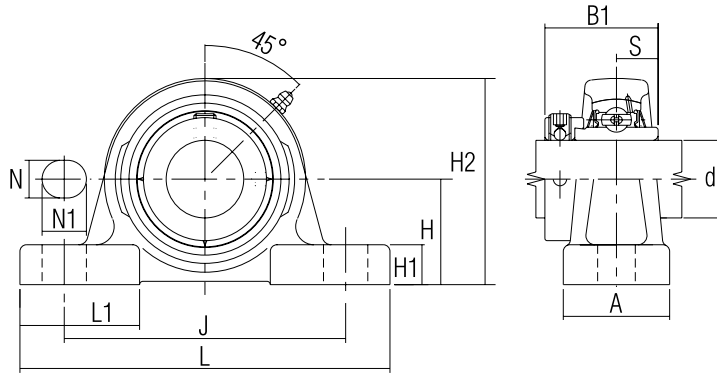

PILLOW BLOCKS - ULTRA CLASS

Part Number	Nominal Dimensions												Bolt Size	Lube Hole of Housing	Insert Bearing Number	Housing Number
	d	H	L	J	A	N	N1	H1	H2	L1	B1	S				
UELP-1/2	0.5000	30.2	127	92.1	38	11.1	22.2	14	62	42	37.3	12.4	3/8	1/4-28UNF	A-UEL201-008D1	P201D1V50
UELP-9/16	0.5625	1 3/16	5	3 5/8	1 1/2	7/16	7/8	9/16	2 7/16	1 21/32	1.469	0.488			A-UEL202-009D1	
UELP-5/8	0.6250														A-UEL202-010D1	
UELP-11/16	0.6875														A-UEL203-011D1	
UELP-3/4	0.7500	33.3	127	96	38	11.1	19.8	14	65	42	43.7	17.1	3/8	1/4-28UNF	A-UEL204-012D1	P204D1V50
		1 5/16	5	3 25/32	1 1/2	7/16	25/32	9/16	2 9/16	1 21/32	1.720	0.673				
UELP-13/16	0.8125	36.5	140	104.8	38	11.1	20.6	15	71	42	44.4	17.5	3/8	1/8-27NPT	A-UEL205-013D1	P205D1V50
UELP-7/8	0.8750	1 7/16	5 1/2	4 1/8	1 1/2	7/16	13/16	19/32	2 25/32	1 21/32	1.748	0.689			A-UEL205-014D1	
UELP-15/16	0.9375														A-UEL205-015D1	
UELP-1	1.0000														A-UEL205-100D1	
UELP-1 1/16	1.0625	42.9	165	117.5	48	14.3	23.8	17	83	54	48.4	18.3	1/2	1/8-27NPT	A-UEL206-101D1	P206D1V50
UELP-1 1/8	1.1250	1 11/16	6 1/2	4 5/8	1 7/8	9/16	15/16	21/32	3 9/32	2 1/8	1.906	0.720			A-UEL206-102D1	
UELP-1 3/16	1.1875														A-UEL206-103D1	
UELP-1 1/4S	1.2500														A-UEL206-104D1	
UELP-1 1/4	1.2500	47.6	167	130.2	48	14.3	24.6	18	93	54	51.1	18.8	1/2	1/8-27NPT	A-UEL207-104D1	P207D1V50
UELP-1 5/16	1.3125	1 7/8	6 9/16	5 1/8	1 7/8	9/16	31/32	23/32	3 21/32	2 1/8	2.012	0.740			A-UEL207-105D1	
UELP-1 3/8	1.3750														A-UEL207-106D1	
UELP-1 7/16	1.4375														A-UEL207-107D1	
UELP-1 1/2	1.5000	49.2	184	136.5	54	14.3	26.2	18	98	52	56.3	21.4	1/2	1/8-27NPT	A-UEL208-108D1	P208D1V50
UELP-1 9/16	1.5625	1 15/16	7 1/4	5 3/8	2 1/8	9/16	1 1/32	23/32	3 27/32	2 1/16	2.217	0.843			A-UEL208-109D1	
UELP-1 5/8	1.6250	54	190	149.2	54	14.3	28.6	20	106	60	56.3	21.4	1/2	1/8-27NPT	A-UEL209-110D1	P209D1V50
UELP-1 11/16	1.6875	2 1/8	7 15/32	5 7/8	2 1/8	9/16	1 1/8	25/32	4 3/16	2 3/8	2.217	0.843			A-UEL209-111D1	
UELP-1 3/4	1.7500														A-UEL209-112D1	
UELP-1 13/16	1.8125	57.2	206	158	60	17.5	23.8	21	114	65	62.7	24.6	5/8	1/8-27NPT	A-UEL210-113D1	P210D1V50
UELP-1 7/8	1.8750	2 1/4	8 1/8	6 7/32	2 3/8	11/16	15/16	13/16	4 1/2	2 9/16	2.469	0.969			A-UEL210-114D1	
UELP-1 15/16	1.9375														A-UEL210-115D1	
UELP-2S	2.0000														A-UEL210-200D1	
UELP-2	2.0000	63.5	219	176.2	60	18.3	29.4	23	126	65	71.4	27.8	5/8	1/8-27NPT	A-UEL211-200D1	P211D1V50
UELP-2 1/16	2.0625	2 1/2	8 5/8	6 15/16	2 3/8	23/32	1 5/32	29/32	4 31/32	2 9/16	2.811	1.094			A-UEL211-201D1	
UELP-2 1/8	2.1250														A-UEL211-202D1	
UELP-2 3/16	2.1875														A-UEL211-203D1	
UELP-2 1/4	2.2500	69.8	241	188.1	70	18.3	29.4	25	138	70	77.8	31.0	5/8	1/8-27NPT	A-UEL212-204D1	P212D1V50
UELP-2 5/16	2.3125	2 3/4	9 1/2	7 13/32	2 3/4	23/32	1 5/32	31/32	5 7/16	2 3/4	3.063	1.220			A-UEL212-205D1	
UELP-2 3/8	2.3750														A-UEL212-206D1	
UELP-2 7/16	2.4375														A-UEL212-207D1	
UELP-2 1/2	2.5	76.2	265	203	70	25	28	27	151	77	85.7	34.15	3/4	1/8-27NPT	A-UEL213-208D1	P213D1V50
UELP-2 9/16	2.5625	3	10 7/16	8	2 3/4	31/32	1 3/32	1 1/16	5 5/16	3 1/32	3.374	1.344			A-UEL213-209D1	
UELP-2 5/8R	2.625	79.4	266	210	72	25	28	27	157	77	85.7	34.15	3/4	1/8-27NPT	A-UEL214-210D1	P214D1V50
UELP-2 11/16R	2.6875	3 1/8	10 15/32	8 9/32	2 5/8	31/32	1 3/32	1 1/16	6 3/16	3 1/32	3.374	1.344			A-UEL214-211D1	
UELP-2 3/4R	2.75														A-UEL214-212D1	
UELP-2 13/16	2.8125	82.6	275	215.9	74	22.2	31.8	28	163	80	92	37.3	3/4	1/8-27NPT	A-UEL215-213D1	P215D1V50
UELP-2 7/8	2.8750	3 1/4	10 13/16	8 1/2	2 29/32	7/8	1 1/4	1 3/32	6 13/32	3 5/32	3.622	1.469			A-UEL215-214D1	
UELP-2 15/16	2.9375														A-UEL215-215D1	
UELP-3	3.0000														A-UEL215-300D1	

Note: Metric Sizes available. The production and shipment of black oxide coated inserts will be introduced as a rolling change. This is denoted with an M at the end of the current part number. Please consult NTN for availability.

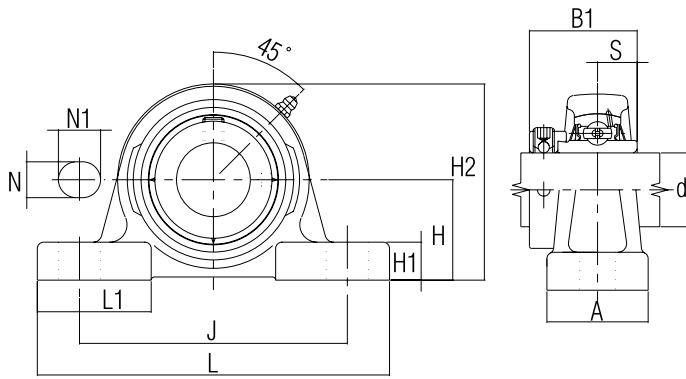

Units: Millimeters
INCHES



PILLOW BLOCKS - ULTRA CLASS

Part Number	Nominal Dimensions												Bolt Size	Lube Hole of Housing	Insert Bearing Number	Housing Number
	d	H	L	J	A	N	N1	H1	H2	L1	B1	S				
UELPL-1/2	0.5000	27	121	92.1	34.9	11.1	22.2	13	54	40	37.3	12.4	3/8	1/4-28UNF	A-UEL201-008D1 A-UEL202-009D1 A-UEL202-010D1 A-UEL203-011D1	PL201D1V50
UELPL-9/16	0.5625	1 1/16	4 3/4	3 5/8	1 3/8	7/16	7/8	1/2	2 1/8	1 9/16	1.469	0.488				
UELPL-5/8	0.6250															
UELPL-11/16	0.6875															
UELPL-3/4	0.7500	31.75	127	96	38.1	11.1	19.8	14	64	42	43.7	17.1	3/8	1/4-28UNF	A-UEL204-012D1	PL204D1V50
UELPL-13/16	0.8125	33.3	140	104.8	38.1	11.1	20.6	15	68	42	44.4	17.5				
UELPL-7/8	0.8750	1 5/16	5 1/2	4 1/8	1 1/2	7/16	13/16	19/32	2 11/16	1 21/32	1.748	0.689				
UELPL-15/16	0.9375															
UELPL-1	1.0000															
UELPL-1 1/16	1.0625	39.7	165	117.5	47.6	14.3	23.8	17	80	54	48.4	18.3	1/2	1/8-27NPT	A-UEL206-101D1 A-UEL206-102D1 A-UEL206-103D1 A-UEL206-104D1	PL206D1V50
UELPL-1 1/8	1.1250	1 9/16	6 1/2	4 5/8	1 7/8	9/16	15/16	21/32	3 5/32	2 1/8	1.906	0.720				
UELPL-1 3/16	1.1875															
UELPL-1 1/4	1.2500															
UELPL-1 1/4	1.2500	46	167	130.2	47.6	14.3	24.6	18	91	54	51.1	18.8	1/2	1/8-27NPT	A-UEL207-104D1 A-UEL207-105D1 A-UEL207-106D1 A-UEL207-107D1	PL207D1V50
UELPL-1 5/16	1.3125	1 13/16	6 9/16	5 1/8	1 7/8	9/16	31/32	23/32	3 19/32	2 1/8	2.012	0.740				
UELPL-1 3/8	1.3750															
UELPL-1 7/16	1.4375															
UELPL-1 1/2	1.5000	49.2	184	136.5	54	14.3	26.2	18	98	52	56.3	21.4	1/2	1/8-27NPT	A-UEL208-108D1 A-UEL208-109D1	P208D1V50
UELPL-1 9/16	1.5625	1 15/16	7 1/4	5 3/8	2 1/8	9/16	1 1/32	23/32	3 27/32	2 1/16	2.217	0.843				
UELPL-1 5/8	1.6250	54	190	149.2	54	14.3	28.6	20	104	60	56.3	21.4	1/2	1/8-27NPT	A-UEL209-110D1 A-UEL209-111D1 A-UEL209-112D1	PL209D1V50
UELPL-1 11/16	1.6875	2 1/8	7 15/32	5 7/8	2 1/8	9/16	1 1/8	25/32	4 3/32	2 3/8	2.217	0.843				
UELPL-1 3/4	1.7500															
UELPL-1 13/16	1.8125	55.6	206	158	60.3	17.5	23.8	21	112	65	62.7	24.6	5/8	1/8-27NPT	A-UEL210-113D1 A-UEL210-114D1 A-UEL210-115D1 A-UEL210-200D1	PL210D1V50
UELPL-1 7/8	1.8750	2 3/16	8 1/8	6 7/32	2 3/8	11/16	15/16	13/16	4 13/32	2 9/16	2.469	0.969				
UELPL-1 15/16	1.9375															
UELPL-2S	2.0000															
UELPL-2	2.0000	61.9	219	176.2	60	18.3	29.4	23	124	65	71.4	27.8	5/8	1/8-27NPT	A-UEL211-200D1 A-UEL211-201D1 A-UEL211-202D1 A-UEL211-203D1	PL211D1V50
UELPL-2 1/16	2.0625	2 7/16	8 5/8	6 15/16	2 3/8	23/32	1 5/32	29/32	4 7/8	2 9/16	2.811	1.094				
UELPL-2 1/8	2.1250															
UELPL-2 3/16	2.1875															
UELPL-2 1/4	2.2500	68.3	241	188.1	69.9	17.5	29.4	25	136	70	77.8	31.0	5/8	1/8-27NPT	A-UEL212-204D1 A-UEL212-205D1 A-UEL212-206D1 A-UEL212-207D1	PL212D1V50
UELPL-2 5/16	2.3125	2 11/16	9 1/2	7 13/32	2 3/4	1 1/16	1 5/32	31/32	5 11/32	2 3/4	3.063	1.220				
UELPL-2 3/8	2.3750															
UELPL-2 7/16	2.4375															
UELPL-2 1/2	2.5000	76.2	265	203.2	70	25	28	27	151	77	85.7	34.15	3/4	1/8-27NPT	A-UEL213-208D1 A-UEL213-209D1	PL213D1V50
UELPL-2 9/16	2.5625	3	10 15/32	8	2 3/4	31/32	1 3/32	1 1/16	5 15/16	3 1/32	3.374	1.344				
UELPL-2 5/8	2.6250	76.2	266	203.2	72.2	20.6	34.9	27	154	77	85.7	34.1	3/4	1/8-27NPT	A-UEL214-210D1 A-UEL214-211D1 A-UEL214-212D1	PL214D1V50
UELPL-2 11/16	2.6875	3	10 15/32	8	2 27/32	13/16	1 3/8	1 1/16	6 1/16	3 1/32	3.374	1.344				
UELPL-2 3/4	2.7500															
UELPL-2 13/16	2.8125	84.1	305	241.3	73.8	22.2	31.8	28	165	80	92	37.3	3/4	1/8-27NPT	A-UEL215-213D1 A-UEL215-214D1 A-UEL215-215D1 A-UEL215-300D1	PL215D1V50
UELPL-2 7/8	2.8750	3 3/16	12	9 1/2	2 29/32	7/8	1 1/4	1 3/32	6 1/2	3 5/32	3.622	1.469				
UELPL-2 15/16	2.9375															
UELPL-3	3.0000															

Note: Metric Sizes available. The production and shipment of black oxide coated inserts will be introduced as a rolling change. This is denoted with an M at the end of the current part number. Please consult NTN for availability.

NTN
SERIES
JELP
ECCENTRIC
LOCKING
COLLAR
TYPE

Units: Millimeters
 INCHES

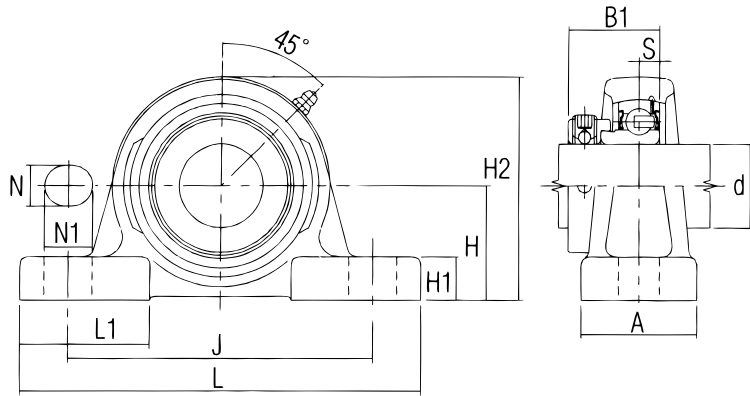

PILLOW BLOCKS - ULTRA CLASS HIGH BASE

Part Number	Nominal Dimensions												Bolt Size	Lube Hole of Housing	Insert Bearing Number	Housing Number
	d	H	L	J	A	N	N1	H1	H2	L1	B1	S				
JELP-1/2	0.5000		127	92.1	38.1	11.1	22.2	14		42	1.126	0.256	3/8	1/4-28UNF	A-JEL201-008D1	PL201D1V50
JELP-9/16	0.5625	1 3/16	5	3 5/8	1 1/2	7/16	7/8	9/16	2 7/16	1 21/32					A-JEL202-009D1	
JELP-5/8	0.6250														A-JEL202-010D1	
JELP-11/16	0.6875														A-JEL203-011D1	
JELP-3/4	0.7500	1 5/16	127	96	38.1	11.1	19.8	14		42	1.220	0.295	3/8	1/4-28UNF	A-JEL204-012D1	PL204D1V50
JELP-13/16	0.8125	1 7/16	140	104.8	38.1	11.1	20.6	15		42	1.220	0.295	3/8	1/8-27NPT	A-JEL205-013D1	
JELP-7/8	0.8750		5 1/2	4 1/8	1 1/2	7/16	13/16	19/32	2 25/32	1 21/32					A-JEL205-014D1	
JELP-15/16	0.9375														A-JEL205-015D1	
JELP-1	1.0000														A-JEL205-100D1	
JELP-1 1/16	1.0625	1 11/16	165	117.5	47.6	14.3	23.8	17		54	1.406	0.354	1/2	1/8-27NPT	A-JEL206-101D1	PL206D1V50
JELP-1 1/8	1.1250		6 1/2	4 5/8	1 7/8	9/16	15/16	21/32	3 9/32	2 1/8					A-JEL206-102D1	
JELP-1 3/16	1.1875														A-JEL206-103D1	
JELP-1 1/4S	1.2500														A-JEL206-104D1	
JELP-1 1/4	1.2500	1 7/8	167	130.2	47.6	14.3	24.6	18		54	1.531	0.374	1/2	1/8-27NPT	A-JEL207-104D1	PL207D1V50
JELP-1 5/16	1.3125		6 9/16	5 1/8	1 7/8	9/16	31/32	23/32	3 21/32	2 1/8					A-JEL207-105D1	
JELP-1 3/8	1.3750														A-JEL207-106D1	
JELP-1 7/16	1.4375														A-JEL207-107D1	
JELP-1 1/2	1.5000	1 15/16	184	136.5	54	14.3	26.2	18		52	1.720	0.433	1/2	1/8-27NPT	A-JEL208-108D1	PL208D1V50
JELP-1 9/16	1.5625		7 1/4	5 3/8	2 1/8	9/16	1 1/32	23/32	3 27/32	2 1/16					A-JEL208-109D1	
JELP-1 5/8	1.6250	2 1/8	190	149.2	54	14.3	28.6	20		60	1.720	0.433	1/2	1/8-27NPT	A-JEL209-110D1	PL209D1V50
JELP-1 11/16	1.6875		7 15/32	5 7/8	2 1/8	9/16	1 1/8	25/32	4 3/16	2 3/8					A-JEL209-111D1	
JELP-1 3/4	1.7500														A-JEL209-112D1	
JELP-1 13/16	1.8125	2 1/4	206	158	60.3	17.5	23.8	21		65	1.720	0.433	5/8	1/8-27NPT	A-JEL210-113D1	PL210D1V50
JELP-1 7/8	1.8750		8 1/8	6 7/32	2 3/8	11/16	19/16	13/16	4 1/2	2 9/16					A-JEL210-114D1	
JELP-1 15/16	1.9375														A-JEL210-115D1	
JELP-2S	2.0000														A-JEL210-200D1	
JELP-2	2.0000	2 1/2	219	176.2	60	18.3	29.4	23		65	1.906	0.472	5/8	1/8-27NPT	A-JEL211-200D1	PL211D1V50
JELP-2 1/16	2.0625		8 5/8	6 15/16	2 3/8	23/32	1 5/32	29/32	4 31/32	2 9/16					A-JEL211-201D1	
JELP-2 1/8	2.1250														A-JEL211-202D1	
JELP-2 3/16	2.1875														A-JEL211-203D1	

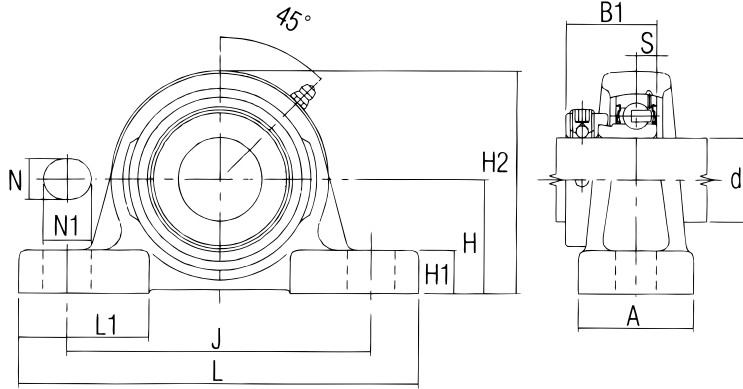

Units: Millimeters
INCHES



PILLOW BLOCKS - ULTRA CLASS LOW BASE

Part Number	Nominal Dimensions												Bolt Size	Lube Hole of Housing	Insert Bearing Number	Housing Number
	d	H	L	J	A	N	N1	H1	H2	L1	B1	S				
JELPL-1/2	0.5000	27	121	92.1	34.9	11.1	22.2	13	54	40			3/8	1/4-28UNF	A-JEL201-008D1	PL201D1V50
JELPL-9/16	0.5625	1 1/16	4 3/4	3 5/8	1 3/8	7/16	7/8	1/2	2 1/8	1 9/16	1.126	0.256			A-JEL202-009D1	
JELPL-5/8	0.6250														A-JEL202-010D1	
JELPL-11/16	0.6875														A-JEL203-011D1	
JELPL-3/4	0.7500	31.75	127	96	38.1	11.1	19.8	14	64	42			3/8	1/4-28UNF	A-JEL204-012D1	PL204D1V50
		1 1/4	5	3 29/32	1 1/2	7/16	29/32	9/16	2 17/32	1 21/32	1.220	0.295				
JELPL-13/16	0.8125	33.3	140	104.8	38.1	11.1	20.6	15	68	42			3/8	1/8-27NPT	A-JEL205-013D1	PL205D1V50
JELPL-7/8	0.8750	1 5/16	5 1/2	4 1/8	1 1/2	7/16	13/16	19/32	2 11/16	1 21/32	1.220	0.295			A-JEL205-014D1	
JELPL-15/16	0.9375														A-JEL205-015D1	
JELPL-1	1.0000														A-JEL205-100D1	
JELPL-1 1/16	1.0625	39.7	165	117.5	47.6	14.3	23.8	17	80	54			1/2	1/8-27NPT	A-JEL206-101D1	PL206D1V50
JELPL-1 1/8	1.1250	1 9/16	6 1/2	4 5/8	1 7/8	9/16	15/16	21/32	3 5/32	2 1/8	1.406	0.354			A-JEL206-102D1	
JELPL-1 3/16	1.1875														A-JEL206-103D1	
JELPL-1 1/4	1.2500														A-JEL206-104D1	
JELPL-1 1/4	1.2500	46	167	130.2	47.6	14.3	24.6	18	91	54			1/2	1/8-27NPT	A-JEL207-104D1	PL207D1V50
JELPL-1 5/16	1.3125	1 13/16	6 9/16	5 1/8	1 7/8	9/16	31/32	23/32	3 19/32	2 1/8	1.531	0.374			A-JEL207-105D1	
JELPL-1 3/8	1.3750														A-JEL207-106D1	
JELPL-1 7/16	1.4375														A-JEL207-107D1	
JELPL-1 1/2	1.5000	49.2	184	136.5	54	14.3	26.2	18	98	52			1/2	1/8-27NPT	A-JEL208-108D1	P208D1V50
JELPL-1 9/16	1.5625	1 15/16	7 1/4	5 3/8	2 1/8	9/16	1 1/2	23/32	3 27/32	2 1/16	1.720	0.374			A-JEL208-109D1	
JELPL-1 5/8	1.6250	52.4	190	149.2	54	14.3	28.6	20	104	60			1/2	1/8-27NPT	A-JEL209-110D1	PL209D1V50
JELPL-1 11/16	1.6875	2 1/16	7 15/32	5 7/8	2 1/8	9/16	1 1/8	25/32	4 3/32	2 3/8	1.720	0.433			A-JEL209-111D1	
JELPL-1 3/4	1.7500														A-JEL209-112D1	
JELPL-1 13/16	1.8125	55.6	206	158	60.3	17.5	23.8	21	112	65			5/8	1/8-27NPT	A-JEL210-113D1	PL210D1V50
JELPL-1 7/8	1.8750	2 3/16	8 1/8	6 7/32	2 3/8	11/16	15/16	13/16	4 13/32	2 9/16	1.720	0.433			A-JEL210-114D1	
JELPL-1 15/16	1.9375														A-JEL210-115D1	
JELPL-2S	2.0000														A-JEL210-200D1	
JELPL-2	2.0000	61.9	219	176.2	60	18.3	29.4	23	124	65			5/8	1/8-27NPT	A-JEL211-200D1	PL211D1V50
JELPL-2 1/16	2.0625	2 7/16	8 5/8	6 15/16	2 3/8	23/32	1 5/32	29/32	4 7/8	2 9/16	1.906	0.472			A-JEL211-201D1	
JELPL-2 1/8	2.1250														A-JEL211-202D1	
JELPL-2 3/16	2.1875														A-JEL211-203D1	

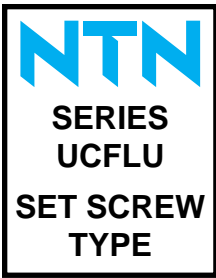

Units: Millimeters
INCHES

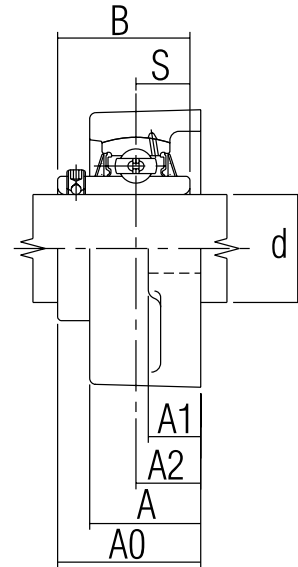
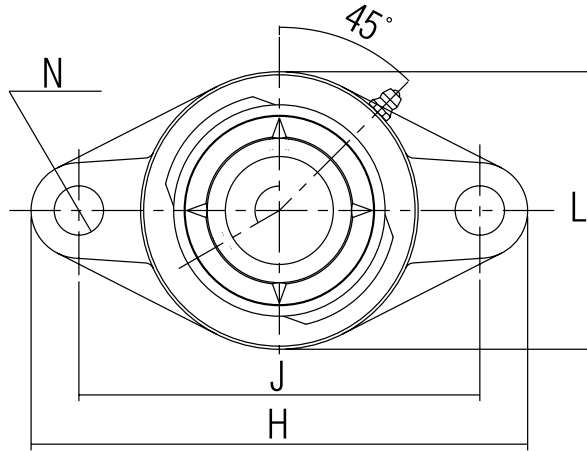

FLANGED UNITS - ULTRA CLASS CAST IRON HOUSING (2 BOLT)

Part Number	Nominal Dimensions											Lube Hole of Housing	Insert Bearing Number	Housing Number		
	d	H	J	A2	A1	A	N	L	A0	B	S					
UCFLU-1/2	0.5000	98	76	17	13	28	9.9	61	32.9	27.4	11.5	1/4-28UNF	A-UC201X-008D1	FLU201D1V50		
UCFLU-9/16	0.5625	3 27/32	3	21/32	33/64	1 7/64	25/64	2 13/32	1 19/64	1.0787	0.453		A-UC202X-009D1			
UCFLU-5/8	0.6250												A-UC202X-010D1			
UCFLU-11/16	0.6875												A-UC203X-011D1			
UCFLU-3/4	0.7500	113	90	19	15	29.5	10.7	61	37.3	31	12.7	1/4-28UNF	A-UC204-012D1	FLU204D1V50		
		4 7/16	3 17/32	3/4	19/32	1 5/32	27/64	2 13/32	1 15/32	1.2205	0.500					
UCFLU-13/16	0.8125	125	99	19	15	30	11.9	70	38.9	34.1	14.3		1/8-27NPT		A-UC205-013D1	FLU205D1V50
UCFLU-7/8	0.8750	4 29/32	3 57/64	3/4	19/32	1 3/16	15/32	2 3/4	1 17/32	1.3425	0.563				A-UC205-014D1	
UCFLU-15/16	0.9375											A-UC205-015D1				
UCFLU-1	1.0000											A-UC205-100D1				
UCFLU-1 1/16	1.0625	142	116.5	20	16	33	11.5	83	42.1	38.1	15.9	1/8-27NPT	A-UC206-101D1	FLU206D1V50		
UCFLU-1 1/8	1.1250	5 19/32	4 19/32	25/32	5/8	1 5/16	29/64	3 9/32	1 21/32	1.5000	0.626		A-UC206-102D1			
UCFLU-1 3/16	1.1875												A-UC206-103D1			
UCFLU-1 1/4S	1.2500												A-UC206-104D1			
UCFLU-1 1/4	1.2500	156	130	21	17	36	14.3	96	46.4	42.9	17.5	1/8-27NPT	A-UC207-104D1	FLU207D1V50		
UCFLU-1 5/16	1.3125	6 5/32	5 1/8	53/64	21/32	1 13/32	9/16	3 25/32	1 53/64	1.6890	0.689		A-UC207-105D1			
UCFLU-1 3/8	1.3750												A-UC207-106D1			
UCFLU-1 7/16	1.4375												A-UC207-107D1			
UCFLU-1 1/2	1.5000	172	143.5	24	17	39	13.1	105	54.4	49.2	19	1/8-27NPT	A-UC208-108D1	FLU208D1V50		
UCFLU-1 9/16	1.5625	6 25/32	5 21/32	15/16	21/32	1 13/32	33/64	4 1/8	2 9/64	1.9370	0.748		A-UC208-109D1			
UCFLU-1 5/8	1.6250	183	148.5	24	18	40	13.1	111	54.4	49.2	19	1/8-27NPT	A-UC208-110D1	FLU209D1V50		
UCFLU-1 11/16	1.6875	7 3/32	5 27/32	15/16	23/32	1 9/16	33/64	4 3/8	2 9/64	1.9370	0.748		A-UC209-111D1			
UCFLU-1 3/4	1.7500												A-UC209-112D1			
UCFLU-1 13/16	1.8125	190	157	28	20	46	17.1	116	60.7	51.6	19	1/8-27NPT	A-UC210-113D1	FLU209D1V50		
UCFLU-1 7/8	1.8750	7 15/32	6 3/16	1 7/64	25/32	1 13/16	43/64	4 9/16	2 25/64	2.0315	0.748		A-UC210-114D1			
UCFLU-1 15/16	1.9375												A-UC210-115D1			
UCFLU-2S	2.0000												A-UC210-200D1			
UCFLU-2	2.0000	217	184	31	20.5	49	17.1	134	64.3	55.6	22.2	1/8-27NPT	A-UC211-200D1	FLU211D1V50		
UCFLU-2 1/16	2.0625	8 17/32	7 1/4	1 1/32	13/16	1 15/16	43/64	5 5/32	2 17/32	2.1890	0.874		A-UC211-201D1			
UCFLU-2 1/8	2.1250												A-UC211-202D1			
UCFLU-2 3/16	2.1875												A-UC211-203D1			

Note: Metric Sizes available. The production and shipment of black oxide coated inserts will be introduced as a rolling change. This is denoted with an M at the end of the current part number. Please consult NTN for availability.

Units: Millimeters
INCHES

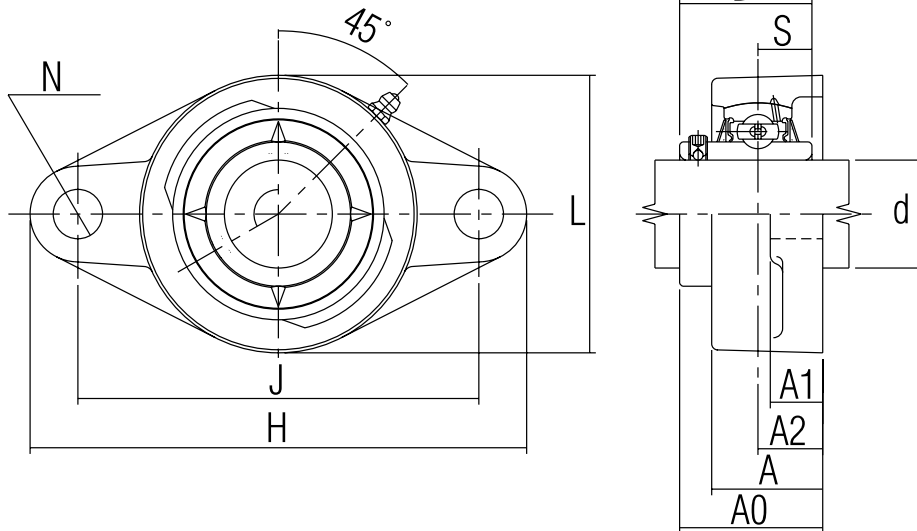
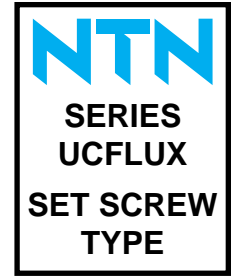

FLANGED UNITS - ULTRA CLASS CAST IRON HOUSING (2 BOLT)

Part Number	Nominal Dimensions											Lube Hole of Housing	Insert Bearing Number	Housing Number
	d	H	J	A2	A1	A	N	L	A0	B	S			
UCFLUX-1 ³ / ₁₆	0.8125	142	116.5	20	16	33	11.5	83	42.1	38.1	15.9	1/8-27NPT	A-UCX05-013D1	FLU206D1V50
UCFLUX-7/8	0.8750	5 19/32	4 19/32	25/32	5/8	1 5/16	29/64	3 3/32	1 21/32	1.5000	0.626		A-UCX05-014D1	
UCFLUX-15/16	0.9375												A-UCX05-015D1	
UCFLUX-1	1.0000												A-UCX05-100D1	
UCFLUX-1 1/16	1.0625	156	130	21	17	36	13.1	96	46.4	42.9	17.5	1/8-27NPT	A-UCX06-101D1	FLU207D1V50
UCFLUX-1 1/8	1.1250	6 5/32	5 1/8	53/64	21/32	1 13/32	33/64	3 25/32	1 53/64	1.6890	0.689		A-UCX06-102D1	
UCFLUX-1 3/16	1.1875												A-UCX06-103D1	
UCFLUX-1 1/4	1.2500												A-UCX07-104D1	
UCFLUX-1 5/16	1.3125	172	143.5	24	17	39	13.1	105	54.4	49.2	19	1/8-27NPT	A-UCX07-105D1	FLU208D1V50
UCFLUX-1 3/8	1.3750	6 25/32	5 21/32	15/16	21/32	1 13/32	33/64	4 1/8	2 9/64	1.9370	0.748		A-UCX07-106D1	
UCFLUX-1 7/16	1.4375												A-UCX07-107D1	
UCFLUX-1 1/2	1.5000	183	148.5	24	18	40	13.1	111	54.4	49.2	19	1/8-27NPT	A-UCX08-108D1	FLU209D1V50
UCFLUX-1 9/16	1.5625	7 3/32	5 27/32	15/16	23/32	1 9/16	33/64	4 3/8	2 9/64	1.9370	0.748		A-UCX08-109D1	
UCFLUX-1 5/8	1.6250	190	157	28	20	46	17.1	116	60.7	51.6	19	1/8-27NPT	A-UCX09-110D1	FLU210D1V50
UCFLUX-1 11/16	1.6875	7 15/32	6 3/16	1 7/64	25/32	1 13/16	43/64	4 9/16	2 25/64	2.0315	0.748		A-UCX09-111D1	
UCFLUX-1 3/4	1.7500												A-UCX09-112D1	
UCFLUX-1 13/16	1.8125												A-UCX10-113D1	
UCFLUX-1 7/8	1.8750	217	184	31	20.5	49	17.1	134	64.3	55.6	22.2	1/8-27NPT	A-UCX10-114D1	FLU211D1V50
UCFLUX-1 15/16	1.9375	8 17/32	7 1/4	1 7/32	13/16	1 15/16	43/64	5 9/32	2 17/32	2.1890	0.874		A-UCX10-115D1	
UCFLUX-2	2.0000												A-UCX11-200D1	

Note: Metric Sizes available. The production and shipment of black oxide coated inserts will be introduced as a rolling change. This is denoted with an M at the end of the current part number. Please consult NTN for availability.

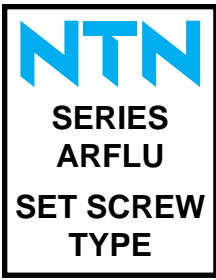

Units: Millimeters
INCHES

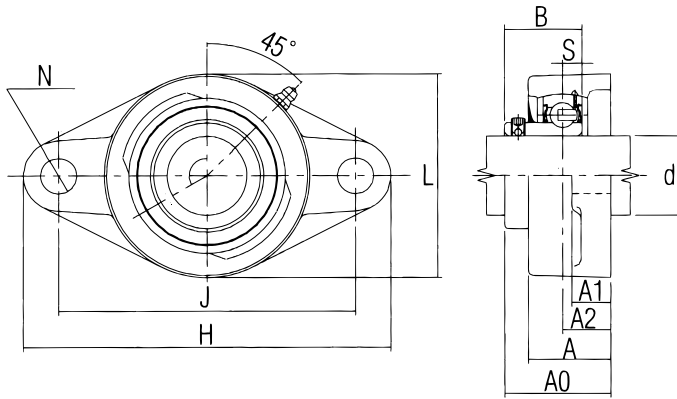

FLANGED UNITS - ULTRA CLASS CAST IRON HOUSING (2 BOLT)

Part Number	Nominal Dimensions											Lube Hole of Housing	Insert Bearing Number	Housing Number
	d	H	J	A2	A1	A	N	L	A0	B1	S			
ARFLU-1/2	0.5000	98	76	17	13	28	9.9	61	1 19/64	1.8858	0.256	1/4-28UNF	A-AR201-008D1	FLU201D1V50
ARFLU-9/16	0.5625	3 27/32	3	21/32	33/64	1 7/64	25/64	2 13/32	1 29/64				A-AR202-009D1	
ARFLU-5/8	0.6250												A-AR202-010D1	
ARFLU-11/16	0.6875												A-AR203-011D1	
ARFLU-3/4	0.7500	113	90	19	15	29.5	10.7	61	1 29/64	1.0039	0.295	1/4-28UNF	A-AR204-012D1	FLU204D1V50
ARFLU-13/16	0.8125	125	99	19	15	30	11.9	70	1 33/64	1.0630	0.295	1/8-27NPT	A-AR205-013D1	FLU205D1V50
ARFLU-7/8	0.8750	4 29/32	3 57/64	3/4	19/32	1 3/16	15/32	2 3/4					A-AR205-014D1	
ARFLU-15/16	0.9375												A-AR205-015D1	
ARFLU-1	1.0000												A-AR205-100D1	
ARFLU-1 1/16	1.0625	142	116.5	20	16	33	11.5	83	1 39/64	1.1811	0.354	1/8-27NPT	A-AR206-101D1	FLU206D1V50
ARFLU-1 1/8	1.1250	5 19/32	4 19/32	25/32	5/8	1 5/16	29/64	3 9/32					A-AR206-102D1	
ARFLU-1 3/16	1.1875												A-AR206-103D1	
ARFLU-1 1/4S	1.2500												A-AR206-104D1	
ARFLU-1 1/4	1.2500	156	130	21	17	36	13.1	96	1 53/64	1.3780	0.374	1/8-27NPT	A-AR207-104D1	FLU207D1V50
ARFLU-1 5/16	1.3125	6 5/32	5 1/8	53/64	21/32	1 13/32	33/64	3 25/32					A-AR207-105D1	
ARFLU-1 3/8	1.3750												A-AR207-106D1	
ARFLU-1 7/16	1.4375												A-AR207-107D1	
ARFLU-1 1/2	1.5000	172	143.5	24	17	39	13.1	105	2 3/32	1.5748	0.433	1/8-27NPT	A-AR208-108D1	FLU208D1V50
ARFLU-1 9/16	1.5625	6 25/32	5 21/32	15/16	21/32	1 17/32	33/64	4 1/8					A-AR208-109D1	
ARFLU-1 5/8	1.6250	183	148.5	24	18	40	13.1	111	2 9/64	1.6339	0.433	1/8-27NPT	A-AR209-110D1	FLU209D1V50
ARFLU-1 11/16	1.6875	7 3/32	5 27/32	15/16	23/32	1 9/16	33/64	4 3/8					A-AR209-111D1	
ARFLU-1 3/4	1.7500												A-AR209-112D1	
ARFLU-1 13/16	1.8125	190	157	28	20	46	17.1	116	2 23/64	1.6929	0.433	1/8-27NPT	A-AR210-113D1	FLU210D1V50
ARFLU-1 7/8	1.8750	7 15/32	6 3/16	1 7/64	25/32	1 13/16	43/64	4 9/16					A-AR210-114D1	
ARFLU-1 15/16	1.9375												A-AR210-115D1	
ARFLU-2S	2.0000												A-AR210-200D1	
ARFLU-2	2.0000	217	184	31	20.5	49	17.1	134	2 7/16	1.6929	0.472	1/8-27NPT	A-AR211-200D1	FLU211D1V50
ARFLU-2 1/16	2.0625	8 17/32	7 1/4	1 7/32	13/16	1 15/16	43/64	5 9/32					A-AR211-201D1	
ARFLU-2 1/8	2.1250												A-AR211-202D1	
ARFLU-2 3/16	2.1875												A-AR211-203D1	

Units: Millimeters
INCHES

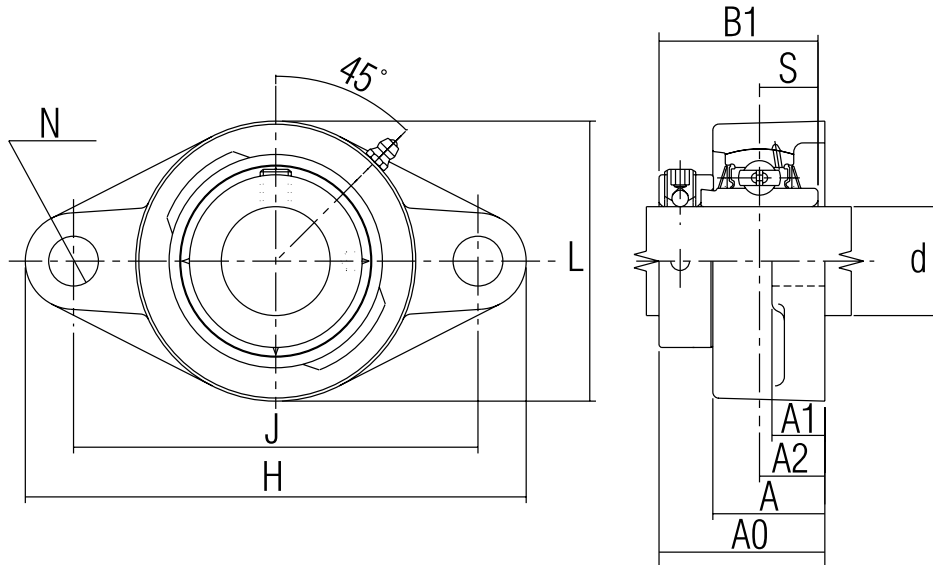

FLANGED UNITS - ULTRA CLASS CAST IRON HOUSING (2 BOLT)

Part Number	Nominal Dimensions											Lube Hole of Housing	Insert Bearing Number	Housing Number	
	d	H	J	A2	A1	A	N	L	A0	B1	S				
UELFLU-1/2	0.5000	98	76	17	13	28	9.9	61	42	37.3	12.4	1/4-28UNF	A-UEL201-008D1	FLU201D1V50	
UELFLU-9/16	0.5625	3 27/32	3	21/32	33/64	1 7/64	25/64	2 13/32	1 21/32	1.469	0.488		A-UEL202-009D1		
UELFLU-5/8	0.6250												A-UEL202-010D1		
UELFLU-11/16	0.6875												A-UEL203-011D1		
UELFLU-3/4	0.7500	113	90	19	15	29.5	10.7	61	45.6	43.7	17.1	1/4-28UNF	A-UEL204-012D1	FLU204D1V50	
		4 7/16	3 17/32	3/4	19/32	1 5/32	27/64	2 13/32	1 51/64	1.720	0.673		A-UEL205-013D1		
UELFLU-13/16	0.8125	125	99	19	15	30	11.9	70	45.9	44.4	17.5		1/8-27NPT		A-UEL205-014D1
UELFLU-7/8	0.8750	4 29/32	3 57/64	3/4	19/32	1 3/16	15/32	2 3/4	1 13/16	1.748	0.689				A-UEL205-015D1
UELFLU-15/16	0.9375											A-UEL205-100D1			
UELFLU-1	1.0000														
UELFLU-1 1/16	1.0625	142	116.5	20	16	33	11.5	83	50.1	48.4	18.3	1/8-27NPT	A-UEL206-101D1	FLU206D1V50	
UELFLU-1 1/8	1.1250	5 19/32	4 19/32	25/32	5/8	1 3/16	29/64	3 9/32	1 31/32	1.906	0.720		A-UEL206-102D1		
UELFLU-1 3/16	1.1875												A-UEL206-103D1		
UELFLU-1 1/4S	1.2500												A-UEL206-104D1		
UELFLU-1 1/4	1.2500	156	130	21	17	36	13.1	96	53.3	51.1	18.8	1/8-27NPT	A-UEL207-104D1	FLU207D1V50	
UELFLU-1 5/16	1.3125	6 5/32	5 1/8	53/64	21/32	1 13/32	33/64	3 25/32	2 3/32	2.012	0.740		A-UEL207-105D1		
UELFLU-1 3/8	1.3750												A-UEL207-106D1		
UELFLU-1 7/16	1.4375												A-UEL207-107D1		
UELFLU-1 1/2	1.5000	172	143.5	24	17	39	13.1	105	58.9	56.3	21.4	1/8-27NPT	A-UEL208-108D1	FLU208D1V50	
UELFLU-1 9/16	1.5625	6 25/32	5 21/32	15/16	21/32	1 13/32	33/64	4 1/8	2 5/16	2.217	0.843		A-UEL208-109D1		
UELFLU-1 5/8	1.6250	183	148.5	24	18	40	13.1	111	58.9	56.3	21.4	1/8-27NPT	A-UEL208-110D1	FLU209D1V50	
UELFLU-1 11/16	1.6875	7 3/32	5 27/32	15/16	23/32	1 9/16	33/64	4 3/8	2 5/16	2.217	0.843		A-UEL209-111D1		
UELFLU-1 3/4	1.7500												A-UEL209-112D1		
UELFLU-1 13/16	1.8125	190	157	28	20	46	17.1	116	66.1	62.7	24.6	1/8-27NPT	A-UEL210-113D1	FLU209D1V50	
UELFLU-1 7/8	1.8750	7 15/32	6 3/16	1 7/64	25/32	1 13/16	43/64	4 9/16	2 39/64	2.469	0.969		A-UEL210-114D1		
UELFLU-1 15/16	1.9375												A-UEL210-115D1		
UELFLU-2S	2.0000												A-UEL210-200D1		
UELFLU-2	2.0000	217	184	31	20.5	49	17.1	134	64.3	55.6	22.2	1/8-27NPT	A-UEL211-200D1	FLU211D1V50	
UELFLU-2 1/16	2.0625	8 17/32	7 1/4	1 7/32	13/16	1 15/16	43/64	5 9/32	2 17/32	2.1890	0.874		A-UEL211-201D1		
UELFLU-2 1/8	2.1250												A-UEL211-202D1		
UELFLU-2 3/16	2.1875												A-UEL211-203D1		

Note: Metric Sizes available. The production and shipment of black oxide coated inserts will be introduced as a rolling change. This is denoted with an M at the end of the current part number. Please consult NTN for availability.

NTN
SERIES
JELFLU
ECCENTRIC
LOCKING
COLLAR
TYPE

Units: Millimeters
 INCHES

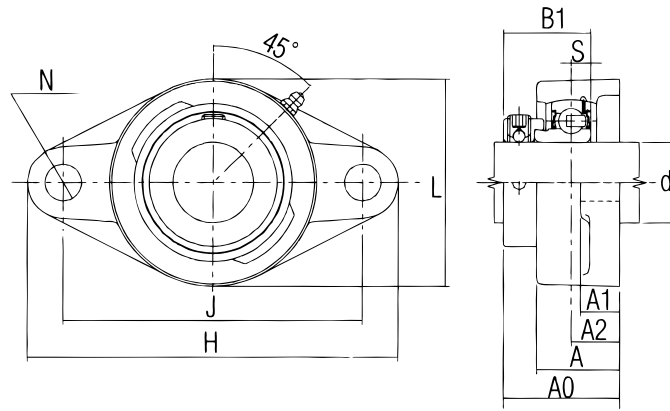

FLANGED UNITS - ULTRA CLASS CAST IRON HOUSING (2 BOLT)

Part Number	Nominal Dimensions											Lube Hole of Housing	Insert Bearing Number	Housing Number
	d	H	J	A2	A1	A	N	L	A0	B1	S			
JELFLU-1/2	0.5000	98	76	17	13	28	9.9	61	1 35/64	1.126	0.256	1/4-28UNF	A-JEL201-008D1	FLU201D1V50
JELFLU-9/16	0.5625	3 27/32	3	21/32	33/64	1 7/64	25/64	2 13/32	1 35/64	1.126	0.256		A-JEL202-009D1	
JELFLU-5/8	0.6250												A-JEL202-010D1	
JELFLU-11/16	0.6875												A-JEL203-011D1	
JELFLU-3/4	0.7500	113	90	19	15	29.5	10.7	61	1 43/64	1.220	0.295	1/4-28UNF	A-JEL204-012D1	FLU204D1V50
JELFLU-13/16	0.8125	4 7/16	3 17/32	3/4	19/32	1 5/32	27/64	2 13/32	1 43/64	1.220	0.295		A-JEL205-013D1	
JELFLU-7/8	0.8750												A-JEL205-014D1	
JELFLU-15/16	0.9375												A-JEL205-015D1	
JELFLU-1	1.0000												A-JEL205-100D1	
JELFLU-1 1/16	1.0625	142	116.5	20	16	33	11.5	83	1 27/32	1.406	0.354	1/8-27NPT	A-JEL206-101D1	FLU206D1V50
JELFLU-1 1/8	1.1250	5 19/32	4 19/32	25/32	5/8	1 5/16	29/64	3 9/32	1 27/32	1.406	0.354		A-JEL206-102D1	
JELFLU-1 3/16	1.1875												A-JEL206-103D1	
JELFLU-1 1/4S	1.2500												A-JEL206-104D1	
JELFLU-1 1/4	1.2500	156	130	21	17	36	13.1	96	1 63/64	1.531	0.374	1/8-27NPT	A-JEL207-104D1	FLU207D1V50
JELFLU-1 5/16	1.3125	6 5/32	5 1/8	53/64	21/32	1 13/32	33/64	3 25/32	1 63/64	1.531	0.374		A-JEL207-105D1	
JELFLU-1 3/8	1.3750												A-JEL207-106D1	
JELFLU-1 7/16	1.4375												A-JEL207-107D1	
JELFLU-1 1/2	1.5000	172	143.5	24	17	39	13.1	105	2 15/64	1.720	0.433	1/8-27NPT	A-JEL208-108D1	FLU208D1V50
JELFLU-1 9/16	1.5625	6 25/32	5 21/32	15/16	21/32	1 17/32	33/64	4 1/8	2 15/64	1.720	0.433		A-JEL208-109D1	
JELFLU-1 5/8	1.6250	183	148.5	24	18	40	13.1	111	2 15/64	1.720	0.433	1/8-27NPT	A-JEL209-110D1	FLU209D1V50
JELFLU-1 11/16	1.6875	7 3/32	5 27/32	15/16	23/32	1 9/16	33/64	4 3/8	2 15/64	1.720	0.433		A-JEL209-111D1	
JELFLU-1 3/4	1.7500												A-JEL209-112D1	
JELFLU-1 13/16	1.8125	190	157	28	20	46	17.1	116	2 25/64	1.720	0.433	1/8-27NPT	A-JEL210-113D1	FLU210D1V50
JELFLU-1 7/8	1.8750	7 15/32	6 3/16	1 7/64	25/32	1 13/16	43/64	4 9/16	2 25/64	1.720	0.433		A-JEL210-114D1	
JELFLU-1 15/16	1.9375												A-JEL210-115D1	
JELFLU-2S	2.0000												A-JEL210-200D1	
JELFLU-2	2.0000	217	184	31	20.5	49	17.1	134	2 21/32	1.906	0.472	1/8-27NPT	A-JEL211-200D1	FLU211D1V50
JELFLU-2 1/16	2.0625	8 17/32	7 1/4	1 7/32	13/16	1 15/16	43/64	5 9/32	2 21/32	1.906	0.472		A-JEL211-201D1	
JELFLU-2 1/8	2.1250												A-JEL211-202D1	
JELFLU-2 3/16	2.1875												A-JEL211-203D1	

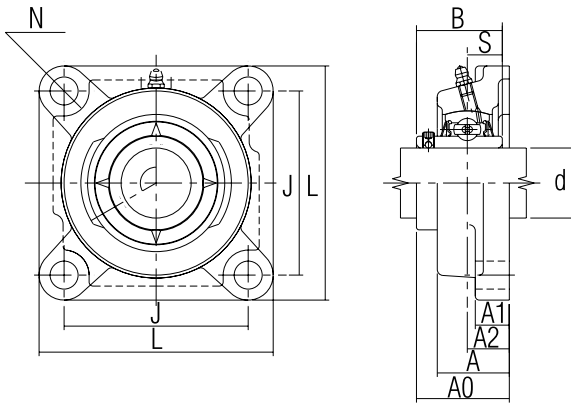

Units: **Millimeters**
INCHES

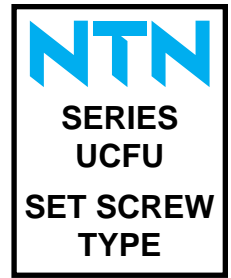

FLANGED UNITS - ULTRA CLASS CAST IRON HOUSING (4 BOLT)

Part Number	Nominal Dimensions										Lube Hole of Housing	Insert Bearing Number	Housing Number		
	d	L	J	A2	A1	A	N	A0	B	S					
UCFU-1/2	0.5000	76	54	17	13	28	10.7	32.9	27.4	11.5	1/4-28UNF	A-UC201X-008D1	FU201D1V50		
UCFU-9/16	0.5625	3	2 1/8	2 1/32	1/2	1 1/64	27/64	1 19/64	1.0787	0.453		A-UC202X-009D1			
UCFU-5/8	0.6250											A-UC202X-010D1			
UCFU-11/16	0.6875											A-UC203X-011D1			
UCFU-3/4	0.7500	86	63.5	19	15	29.5	10.7	37.3	31	12.7	1/4-28UNF	A-UC204-012D1	FU204D1V50		
		3 3/8	2 1/2	3/4	19/32	1 5/32	27/64	1 15/32	1.2205	0.500					
UCFU-13/16	0.8125	96	70	19	15	30	11.5	38.9	34.1	14.3		1/8-27NPT		A-UC205-013D1	FU205D1V50
UCFU-7/8	0.8750	3 25/32	2 3/4	3/4	19/32	1 3/16	29/64	1 17/32	1.3425	0.563				A-UC205-014D1	
UCFU-15/16	0.9375										A-UC205-015D1				
UCFU-1	1.0000										A-UC205-100D1				
UCFU-1 1/16	1.0625	109	82.5	20	16	33	11.5	42.1	38.1	15.9	1/8-27NPT	A-UC206-101D1	FU206D1V50		
UCFU-1 1/8	1.1250	4 9/32	3 1/4	25/32	9/8	1 9/16	29/64	1 21/32	1.5000	0.626		A-UC206-102D1			
UCFU-1 3/16	1.1875											A-UC206-103D1			
UCFU-1 1/4S	1.2500											A-UC206-104D1			
UCFU-1 1/4	1.2500	118	92	21	17	36	13.1	46.4	42.9	17.5	1/8-27NPT	A-UC207-104D1	FU207D1V50		
UCFU-1 5/16	1.3125	4 21/32	3 5/8	53/64	21/32	1 13/32	33/64	1 53/64	1.6890	0.689		A-UC207-105D1			
UCFU-1 3/8	1.3750											A-UC207-106D1			
UCFU-1 7/16	1.4375											A-UC207-107D1			
UCFU-1 1/2	1.5000	131	101.5	24	17	39	13.1	54.3	49.2	19	1/8-27NPT	A-UC208-108D1	FU208D1V50		
UCFU-1 9/16	1.5625	5 3/32	4	15/16	21/32	1 17/32	33/64	2 9/64	1.9370	0.748		A-UC208-109D1			
UCFU-1 5/8	1.6250	137	105	24	17	40	13.1	54.3	49.2	19		1/8-27NPT		A-UC209-110D1	FU209D1V50
UCFU-1 11/16	1.6875	5 13/32	4 1/8	15/16	23/32	1 9/16	33/64	2 9/64	1.9370	0.748				A-UC209-111D1	
UCFU-1 3/4	1.7500										A-UC209-112D1				
UCFU-1 13/16	1.8125	144	111	28	20	46	17.1	60.7	51.6	19	1/8-27NPT	A-UC210-113D1	FU210D1V50		
UCFU-1 7/8	1.8750	5 21/32	4 3/8	1 7/64	25/32	1 13/16	43/64	2 25/64	2.0315	0.748		A-UC210-114D1			
UCFU-1 15/16	1.9375											A-UC210-115D1			
UCFU-2S	2.0000											A-UC210-200D1			
UCFU-2	2.0000	163	130	31	21	49	17.1	64.3	55.6	22.2	1/8-27NPT	A-UC211-200D1	FU211D1V50		
UCFU-2 1/16	2.0625	6 13/32	5 1/8	1 7/32	13/16	1 15/16	43/64	2 17/32	2.1890	0.874		A-UC211-201D1			
UCFU-2 1/8	2.1250											A-UC211-202D1			
UCFU-2 3/16	2.1875											A-UC211-203D1			
UCFU-2 1/4	2.2500	175	143	34	21	53	17.1	73.8	65.1	25.4	1/8-27NPT	A-UC212-204D1	FU212D1V50		
UCFU-2 5/16	2.3125	6 7/8	5 5/8	1 11/32	13/16	2 3/32	43/64	2 29/32	2.5630	1.000		A-UC212-205D1			
UCFU-2 3/8	2.3750											A-UC212-206D1			
UCFU-2 7/16	2.4375											A-UC212-207D1			
UCFU-2 1/2R	2.5000	187	149	38	22	59	19	77.7	65.1	25.4	1/8-27NPT	A-UC213-208D1	FU213D1V50		
UCFU-2 9/16R	2.5625	7 3/8	5 55/64	1 1/2	7/8	2 5/16	3/4	3 1/16	2.563	1		A-UC213-209D1			
UCFU-2 5/8R	2.6250	193	149	38	22	62	16.3	82.6	74.6	30.2	1/8-27NPT	A-UC214-210D1	FU214D1V50		
UCFU-2 11/16R	2.6875	7 19/32	5 7/8	1 1/2	7/8	2 7/16	41/64	3 1/4	2.9370	1.189		A-UC214-211D1			
UCFU-2 3/4R	2.7500											A-UC214-212D1			
UCFU-2 13/16	2.8125	200	152	41	22	65	19.8	85.3	77.8	33.3	1/8-27NPT	A-UC215-213D1	FU215D1V50		
UCFU-2 7/8	2.8750	7 7/8	6	1 39/64	7/8	2 9/16	25/32	3 23/64	3.0630	1.311		A-UC215-214D1			
UCFU-2 15/16	2.9375											A-UC215-215D1			
UCFU-3	3.0000											A-UC215-300D1			

Note: Metric Sizes available. The production and shipment of black oxide coated inserts will be introduced as a rolling change. This is denoted with an M at the end of the current part number. Please consult NTN for availability.

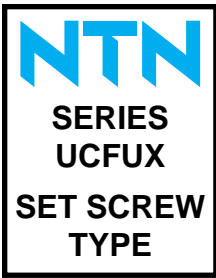

Units: **Millimeters**
INCHES

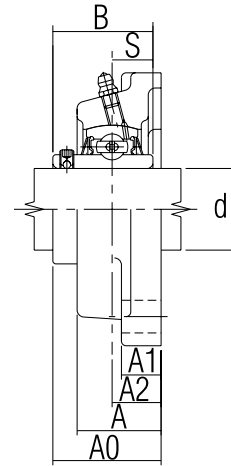
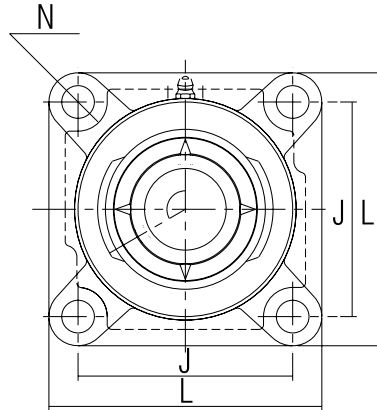

FLANGED UNITS - ULTRA CLASS CAST IRON HOUSING (4 BOLT)

Part Number	Nominal Dimensions										Lube Hole of Housing	Insert Bearing Number	Housing Number
	d	L	J	A2	A1	A	N	A0	B	S			
UCFUX-1 ³ / ₁₆	0.8125	109	82.5	20	16	33	11.5	42.1	38.1	15.9	1/8-27NPT	A-UCX05-013D1	FU206D1V50
UCFUX-7/8	0.8750	4 9/32	3 1/4	25/32	5/8	1 5/16	29/64	1 21/32	1.5000	0.626		A-UCX05-014D1	
UCFUX-15/16	0.9375											A-UCX05-015D1	
UCFUX-1	1.0000											A-UCX05-100D1	
UCFUX-1 1/16	1.0625	118	92	21	17	36	13.1	46.4	42.9	17.5	1/8-27NPT	A-UCX06-101D1	FU207D1V50
UCFUX-1 1/8	1.1250	4 21/32	3 5/8	53/64	21/32	1 13/32	33/64	1 53/64	1.6890	0.689		A-UCX06-102D1	
UCFUX-1 3/16	1.1875											A-UCX06-103D1	
UCFUX-1 1/4	1.2500											A-UCX07-104D1	
UCFUX-1 5/16	1.2500	131	101.5	24	17	39	13.1	54.3	49.2	19	1/8-27NPT	A-UCX07-105D1	FU208D1V50
UCFUX-1 3/8	1.3750	5 3/32	4	15/16	21/32	1 17/32	33/64	2 9/64	1.9370	0.748		A-UCX07-106D1	
UCFUX-1 7/16	1.4375											A-UCX07-107D1	
UCFUX-1 1/2	1.5000	137	105	24	18	40	13.1	54.3	49.2	19	1/8-27NPT	A-UCX08-108D1	FU209D1V50
UCFUX-1 9/16	1.5625	5 13/32	4 1/8	15/16	23/32	1 9/16	33/64	2 9/64	1.9370	0.748		A-UCX08-109D1	
UCFUX-1 5/8	1.6250	144	111	28	20	46	17.1	60.7	51.6	19	1/8-27NPT	A-UCX09-110D1	FU210D1V50
UCFUX-1 11/16	1.6875	5 21/32	4 3/8	1 7/64	29/32	1 13/16	43/64	2 29/64	2.0315	0.748		A-UCX09-111D1	
UCFUX-1 3/4	1.7500											A-UCX09-112D1	
UCFUX-1 13/16	1.8125											A-UCX10-113D1	
UCFUX-1 7/8	1.8750	163	130	31	21	49	17.1	64.3	55.6	22.2	1/8-27NPT	A-UCX10-114D1	FU211D1V50
UCFUX-1 15/16	1.9375	6 13/32	5 1/8	1 7/32	13/16	1 15/16	43/64	2 17/32	2.1890	0.874		A-UCX10-115D1	
UCFUX-2	2.0000											A-UCX11-200D1	
UCFUX-2 1/16	2.0000	175	143	34	21	53	17.1	73.8	65.1	25.4	1/8-27NPT	A-UCX11-201D1	FU212D1V50
UCFUX-2 1/8	2.1250	6 7/8	5 5/8	1 11/32	13/16	2 3/32	43/64	2 29/32	2.5630	1.000		A-UCX11-202D1	
UCFUX-2 3/16	2.1875											A-UCX11-203D1	
UCFUX-2 1/4	2.2500											A-UCX12-204D1	
UCFUX-2 5/16	2.3125											A-UCX12-205D1	
UCFUX-2 7/16	2.4375	193	143	38	22	62	16.3	82.6	74.6	30.2	1/8-27NPT	A-UCX14-207D1	FU214D1V50
UCFUX-2 1/2	2.5000	7 19/32	5 7/8	1 1/2	7/8	2 7/16	41/64	3 1/4	2.9370	1.189		A-UCX13-208D1	
UCFUX-2 9/16	2.5625											A-UCX13-209D1	
UCFUX-2 5/8	2.6250	200	152	41	22	65	19.8	85.3	77.8	33.3	1/8-27NPT	A-UCX14-210D1	FU215D1V50
UCFUX-2 11/16	2.6875	7 7/8	6	1 39/64	7/8	2 9/16	25/32	3 23/64	3.0630	1.311		A-UCX14-211D1	
UCFUX-2 3/4	2.7500											A-UCX14-212D1	
UCFUX-2 13/16	2.8125	200	152.5	40.9	22	65	19.8	90.5	82.6	33.3	1/8-27NPT	A-UCX15-213D1	FU215D1V50
UCFUX-2 7/8	2.8750	7 7/8	6	1 39/64	7/8	2 9/16	25/32	3 9/16	3.2520	1.311		A-UCX15-214D1	
UCFUX-2 15/16	2.9375											A-UCX15-215D1	
UCFUX-3	3.0000											A-UCX15-300D1	

Note: Metric Sizes available. The production and shipment of black oxide coated inserts will be introduced as a rolling change. This is denoted with an M at the end of the current part number. Please consult NTN for availability.

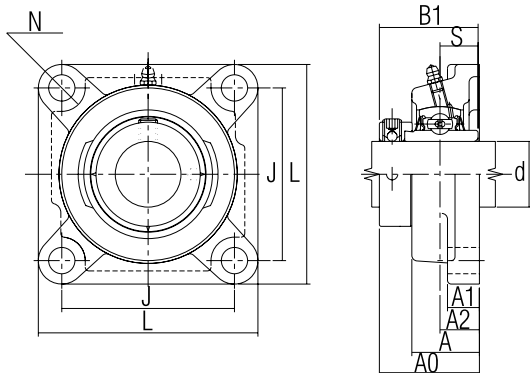

Units: **Millimeters**
INCHES



FLANGED UNITS - ULTRA CLASS CAST IRON HOUSING (4 BOLT)

Part Number	Nominal Dimensions										Lube Hole of Housing	Insert Bearing Number	Housing Number		
	d	L	J	A2	A1	A	N	A0	B1	S					
UEL FU-1/2	0.5000	76	54	17	13	28	10.7	42.1	37.3	12.4	1/4-28UNF	A-UEL201-008D1	FU201D1V50		
UEL FU-9/16	0.5625	3	2 1/8	2 1/32	1/2	1 7/64	27/64	1 2 1/32	1.469	0.488		A-UEL202-009D1			
UEL FU-5/8	0.6250											A-UEL202-010D1			
UEL FU-11/16	0.6875											A-UEL203-011D1			
UEL FU-3/4	0.7500	86	63.5	19	15	29.5	10.7	45.6	43.7	17.1	1/4-28UNF	A-UEL204-012D1	FU204D1V50		
		3 3/8	2 1/2	3/4	19/32	1 5/32	27/64	1 51/64	1.720	0.673					
UEL FU-13/16	0.8125	96	70	19	15	30	11.5	46	44.4	17.5		1/8-27NPT		A-UEL205-013D1	FU205D1V50
UEL FU-7/8	0.8750	3 25/32	2 3/4	3/4	19/32	1 3/16	29/64	1 13/16	1.748	0.689				A-UEL205-014D1	
UEL FU-15/16	0.9375										A-UEL205-015D1				
UEL FU-1	1.0000										A-UEL205-100D1				
UEL FU-1 1/16	1.0625	109	82.5	20	16	33	11.5	50	48.4	18.3	1/8-27NPT	A-UEL206-101D1	FU206D1V50		
UEL FU-1 1/8	1.1250	4 9/32	3 1/4	25/32	9/8	1 5/16	29/64	1 31/32	1.906	0.720		A-UEL206-102D1			
UEL FU-1 3/16	1.1875											A-UEL206-103D1			
UEL FU-1 1/4S	1.2500											A-UEL206-104D1			
UEL FU-1 1/4	1.2500	118	92	21	17	36	13.1	53.2	51.1	18.8	1/8-27NPT	A-UEL207-104D1	FU207D1V50		
UEL FU-1 5/16	1.3125	4 21/32	3 5/8	53/64	21/32	1 13/32	33/64	2 3/32	2.012	0.740		A-UEL207-105D1			
UEL FU-1 3/8	1.3750											A-UEL207-106D1			
UEL FU-1 7/16	1.4375											A-UEL207-107D1			
UEL FU-1 1/2	1.5000	131	101.5	24	17	39	13.1	58.7	56.3	21.4	1/8-27NPT	A-UEL208-108D1	FU208D1V50		
UEL FU-1 9/16	1.5625	5 3/32	4	15/16	21/32	1 17/32	33/64	2 5/16	2.217	0.843		A-UEL208-109D1			
UEL FU-1 5/8	1.6250	137	105	24	17	40	13.1	58.7	56.3	21.4	1/8-27NPT	A-UEL209-110D1	FU209D1V50		
UEL FU-1 11/16	1.6875	5 13/32	4 1/8	15/16	23/32	1 9/16	33/64	2 5/16	2.217	0.843		A-UEL209-111D1			
UEL FU-1 3/4	1.7500											A-UEL209-112D1			
UEL FU-1 13/16	1.8125	144	111	28	20	46	17.1	66.3	62.7	24.6	1/8-27NPT	A-UEL210-113D1	FU210D1V50		
UEL FU-1 7/8	1.8750	5 21/32	4 3/8	1 7/64	25/32	1 13/16	43/64	2 39/64	2.469	0.969		A-UEL210-114D1			
UEL FU-1 15/16	1.9375											A-UEL210-115D1			
UEL FU-2S	2.0000											A-UEL210-200D1			
UEL FU-2	2.0000	163	130	31	21	49	17.1	74.6	71.4	27.8	1/8-27NPT	A-UEL211-200D1	FU211D1V50		
UEL FU-2 1/16	2.0625	6 13/32	5 1/8	1 7/32	13/16	1 15/16	43/64	2 15/16	2.811	1.094		A-UEL211-201D1			
UEL FU-2 1/8	2.1250											A-UEL211-202D1			
UEL FU-2 3/16	2.1875											A-UEL211-203D1			
UEL FU-2 1/4	2.2500	175	143	34	21	53	17.1	81	77.8	31	1/8-27NPT	A-UEL212-204D1	FU212D1V50		
UEL FU-2 5/16	2.3125	6 7/8	5 5/8	1 11/32	13/16	2 3/32	43/64	3 3/16	3.063	1.220		A-UEL212-205D1			
UEL FU-2 3/8	2.3750											A-UEL212-206D1			
UEL FU-2 7/16	2.4375											A-UEL212-207D1			
UEL FU-2 1/2R	2.5000	187	149	38	22	59	19	89.55	85.7	34.15	1/8-27NPT	A-UEL213-208D1M	FU213D1V50		
UEL FU-2 9/16R	2.5625	7 3/8	5 55/64	1 1/2	7/8	2 5/16	3/4	3 1/2	3.374	1.344		A-UEL213-209D1M			
UEL FU-2 5/8R	2.6250	193	149	38	22	62	16.3	89.7	85.7	34.1	1/8-27NPT	A-UEL214-210D1	FU214D1V50		
UEL FU-2 11/16R	2.6875	7 19/32	5 7/8	1 1/2	7/8	2 7/16	41/64	3 17/32	3.374	1.344		A-UEL214-211D1			
UEL FU-2 3/4R	2.7500											A-UEL214-212D1			
UEL FU-2 13/16	2.8125	200	152	41	22	65	19.8	95.6	92	37.3	1/8-27NPT	A-UEL215-213D1	FU215D1V50		
UEL FU-2 7/8	2.8750	7 7/8	6	1 39/64	7/8	2 9/16	25/32	3 49/64	3.622	1.469		A-UEL215-214D1			
UEL FU-2 15/16	2.9375											A-UEL215-215D1			
UEL FU-3	3.0000											A-UEL215-300D1			

Note: Metric Sizes available. The production and shipment of black oxide coated inserts will be introduced as a rolling change. This is denoted with an M at the end of the current part number. Please consult NTN for availability.



Units: **Millimeters**
INCHES

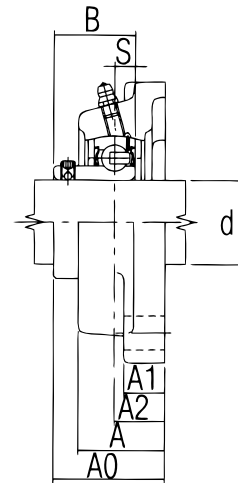
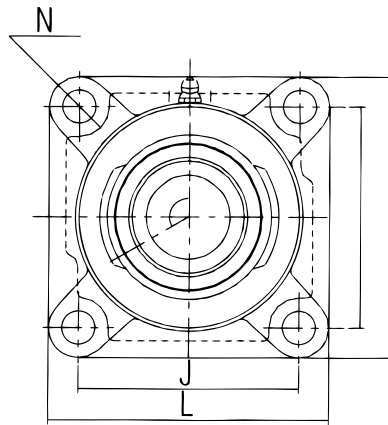

FLANGED UNITS - ULTRA CLASS CAST IRON HOUSING (4 BOLT)

Part Number	Nominal Dimensions										Lube Hole of Housing	Insert Bearing Number	Housing Number	
	d	L	J	A2	A1	A	N	A0	B	S				
ARFU-1/2	0.5000	76	54	17	13	28	10.7					1/4-28UNF	A-AR201-008D1 A-AR202-009D1 A-AR202-010D1 A-AR203-011D1	FU201D1V50
ARFU-9/16	0.5625	3	2 1/8	21/32	1/2	1 1/64	27/64	1 19/64	0.8858	0.256				
ARFU-5/8	0.6250													
ARFU-11/16	0.6875													
ARFU-3/4	0.7500	86	63.5	19	15	29.5					1/4-28UNF	A-AR204-012D1	FU204D1V50	
ARFU-13/16	0.8125	96	70	19	15	30	27/64	1 29/64	1.0039	0.295				
ARFU-7/8	0.8750	3 25/32	2 3/4	3/4	19/32	1 3/16	29/64	1 33/64	1.0630	0.295				
ARFU-15/16	0.9375										1/8-27NPT	A-AR205-013D1 A-AR205-014D1 A-AR205-015D1 A-AR205-100D1	FU205D1V50	
ARFU-1	1.0000													
ARFU-1 1/16	1.0625	109	82.5	20	16	33	11.5	1 39/64	1.1811	0.354				
ARFU-1 1/8	1.1250	4 9/32	3 1/4	25/32	5/8	1 5/16	29/64	1 39/64	1.1811	0.354				
ARFU-1 3/16	1.1875										1/8-27NPT	A-AR206-101D1 A-AR206-102D1 A-AR206-103D1 A-AR206-104D1	FU206D1V50	
ARFU-1 1/4S	1.2500													
ARFU-1 1/4	1.2500	118	92	21	17	36	13.1	1 53/64	1.3780	0.374				
ARFU-1 5/16	1.3125	4 21/32	3 5/8	53/64	21/32	1 13/32	33/64	1 53/64	1.3780	0.374				
ARFU-1 3/8	1.3750										1/8-27NPT	A-AR207-104D1 A-AR207-105D1 A-AR207-106D1 A-AR207-107D1	FU207D1V50	
ARFU-1 7/16	1.4375													
ARFU-1 1/2	1.5000	101.5	24	17	39	13.1	33/64	2 3/32	1.5748	0.433				
ARFU-1 9/16	1.5625	5 5/32	4	15/16	21/32	1 17/32	33/64	2 3/32	1.5748	0.433				
ARFU-1 5/8	1.6250	137	105	24	17	40	13.1	2 9/64	1.6339	0.433	1/8-27NPT	A-AR209-110D1 A-AR209-111D1 A-AR209-112D1	FU209D1V50	
ARFU-1 11/16	1.6875	5 13/32	4 1/8	15/16	23/32	1 9/16	33/64	2 9/64	1.6339	0.433				
ARFU-1 3/4	1.7500													
ARFU-1 13/16	1.8125	144	111	28	20	46	17.1	2 23/64	1.6929	0.433	1/8-27NPT	A-AR210-113D1 A-AR210-114D1 A-AR210-115D1 A-AR210-200D1	FU210D1V50	
ARFU-1 7/8	1.8750	5 21/32	4 3/8	1 7/64	25/32	1 13/16	43/64	2 23/64	1.6929	0.433				
ARFU-1 15/16	1.9375													
ARFU-2S	2.0000													
ARFU-2	2.0000	163	130	31	21	49	17.1	2 7/16	1.6929	0.472	1/8-27NPT	A-AR211-200D1 A-AR211-201D1 A-AR211-202D1 A-AR211-203D1	FU211D1V50	
ARFU-2 1/16	2.0625	6 13/32	5 1/8	1 7/32	13/16	1 15/16	43/64	2 7/16	1.6929	0.472				
ARFU-2 1/8	2.1250													
ARFU-2 3/16	2.1875													

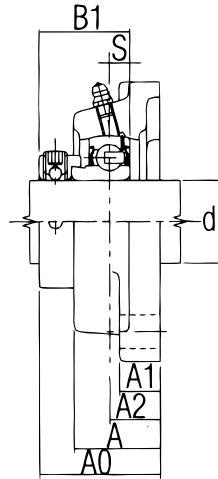
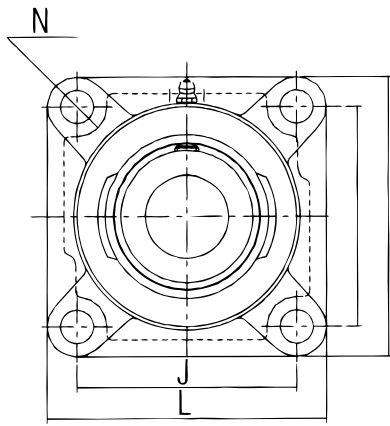

Units: Millimeters
INCHES



FLANGED UNITS - ULTRA CLASS CAST IRON HOUSING (4 BOLT)

Part Number	Nominal Dimensions										Lube Hole of Housing	Insert Bearing Number	Housing Number		
	d	L	J	A2	A1	A	N	A0	B1	S					
JELFU-1/2	0.5000	76	54	17	13	28	10.7	1 35/64	1.126	0.256	1/4-28UNF	A-JEL201-008D1	FU201D1V50		
JELFU-9/16	0.5625	3	2 1/8	21/32	1/2	1 1/64	27/64					A-JEL202-009D1			
JELFU-5/8	0.6250											A-JEL202-010D1			
JELFU-11/16	0.6875											A-JEL203-011D1			
JELFU-3/4	0.7500	86	63.5	19	15	29.5	11.5	1 43/64	1.220	0.295	1/4-28UNF	A-JEL204-012D1	FU204D1V50		
JELFU-13/16	0.8125	96	70	19	15	30	11.5	1 43/64	1.220	0.295	1/8-27NPT	A-JEL205-013D1	FU205D1V50		
JELFU-7/8	0.8750	3 25/32	2 3/4	3/4	19/32	1 3/16	29/64					A-JEL205-014D1			
JELFU-15/16	0.9375											A-JEL205-015D1			
JELFU-1	1.0000											A-JEL205-100D1			
JELFU-1 1/16	1.0625	109	82.5	20	16	33	11.5	1 27/32	1.406	0.354	1/8-27NPT	A-JEL206-101D1	FU206D1V50		
JELFU-1 1/8	1.1250	4 9/32	3 1/4	25/32	5/8	1 5/16	29/64					A-JEL206-102D1			
JELFU-1 3/16	1.1875											A-JEL206-103D1			
JELFU-1 1/4S	1.2500											A-JEL206-104D1			
JELFU-1 1/4	1.2500	118	92	21	17	36	13.1	1 63/64	1.531	0.374	1/8-27NPT	A-JEL207-104D1	FU207D1V50		
JELFU-1 5/16	1.3125	4 21/32	3 5/8	53/64	21/32	1 13/32	33/64					A-JEL207-105D1			
JELFU-1 3/8	1.3750											A-JEL207-106D1			
JELFU-1 7/16	1.4375											A-JEL207-107D1			
JELFU-1 1/2	1.5000	124	101.5	24	17	39	13.1	2 15/64	1.720	0.433	1/8-27NPT	A-JEL208-108D1	FU208D1V50		
JELFU-1 9/16	1.5625	5 5/32	4	15/16	21/32	1 17/32	33/64					A-JEL208-109D1			
JELFU-1 5/8	1.6250	137	105	24	17	40	13.1	2 15/64	1.720	0.433		1/8-27NPT		A-JEL209-110D1	FU209D1V50
JELFU-1 11/16	1.6875	5 13/32	4 1/8	15/16	23/32	1 9/16	33/64							A-JEL209-111D1	
JELFU-1 3/4	1.7500										A-JEL209-112D1				
JELFU-1 13/16	1.8125	144	111	28	20	46	17.1	2 25/64	1.720	0.433	1/8-27NPT	A-JEL210-113D1	FU210D1V50		
JELFU-1 7/8	1.8750	5 21/32	4 3/8	1 7/64	25/32	1 13/16	43/64					A-JEL210-114D1			
JELFU-1 15/16	1.9375											A-JEL210-115D1			
JELFU-2S	2.0000											A-JEL210-200D1			
JELFU-2	2.0000	163	130	31	21	49	17.1	2 21/32	1.906	0.472	1/8-27NPT	A-JEL211-200D1	FU211D1V50		
JELFU-2 1/16	2.0625	6 13/32	5 1/8	1 7/32	13/16	1 15/16	43/64					A-JEL211-201D1			
JELFU-2 1/8	2.1250											A-JEL211-202D1			
JELFU-2 3/16	2.1875											A-JEL211-203D1			



Bearing Series → UCP SERIES

UCP-1/2..... 1.5 ←

Complete Pillow Block Number

Weight (lbs)

ULTRA-CLASS MOUNTED UNITS			LBS.			
UCP Series	UCPL-2.7/8.....	19.0	ARPL-1.3/16.....	3.1	UELPL-1.11/16.....	5.7
UCP-1/2.....	UCPL-2.15/16.....	18.7	ARPL-1.1/4S.....	3.1	UELPL-1.3/4.....	5.7
UCP-9/16.....	UCPL-3.....	18.5	ARPL-1.1/4.....	4.0	UELPL-1.13/16.....	7.7
UCP-5/8.....	UCPX Series		ARPL-1.5/16.....	3.7	UELPL-1.7/8.....	7.7
UCP-11/16.....	UCPX-13/16.....	3.5	ARPL-1.3/8.....	3.7	UELPL-1.15/16.....	7.5
UCP-3/4.....	UCPX-7/8.....	3.5	ARPL-1.7/16.....	3.5	UELPL-2S.....	7.5
UCP-13/16.....	UCPX-15/16.....	3.5	ARPL-1.1/2.....	4.6	UELPL-2.....	9.7
UCP-7/8.....	UCPX-1.....	3.4	ARPL-1.9/16.....	4.6	UELPL-2.1/16.....	9.5
UCP-15/16.....	UCPX-1.1/16.....	4.2	ARPL-1.5/8.....	5.5	UELPL-2.1/8.....	9.5
UCP-1.....	UCPX-1.1/8.....	4.1	ARPL-1.11/16.....	5.3	UELPL-2.3/16.....	9.3
UCP-1.1/16.....	UCPX-1.3/16.....	4.1	ARPL-1.3/4.....	5.3	UELPL-2.1/4.....	13.0
UCP-1.1/8.....	UCPX-1.1/4.....	4.0	ARPL-1.13/16.....	7.1	UELPL-2.5/16.....	12.8
UCP-1.3/16.....	UCPX-1.5/16.....	5.4	ARPL-1.7/8.....	7.1	UELPL-2.3/8.....	12.8
UCP-1.1/4S.....	UCPX-1.3/8.....	5.3	ARPL-1.15/16.....	6.8	UELPL-2.7/16.....	12.6
UCP-1.1/4.....	UCPX-1.7/16.....	5.2	ARPL-2S.....	6.8	UELPL-2.1/2.....	
UCP-1.5/16.....	UCPX-1.1/2.....	5.8	ARPL-2S.....	8.8	UELPL-2.9/16.....	
UCP-1.3/8.....	UCPX-1.9/16.....	5.7	ARPL-2.1/16.....	8.6	UELPL-2.5/8R.....	16.8
UCP-1.7/16.....	UCPX-1.5/8.....	7.7	ARPL-2.1/8.....	8.6	UELPL-2.11/16R.....	16.5
UCP-1.1/2.....	UCPX-1.11/16.....	7.7	ARPL-2.3/16.....	8.4	UELPL-2.3/4R.....	19.8
UCP-1.9/16.....	UCPX-1.3/4.....	7.6	UELP Series		UELPL-2.13/16.....	19.8
UCP-1.5/8.....	UCPX-1.13/16.....	7.4	UELPL-1/2.....	1.8	UELPL-2.7/8.....	19.6
UCP-1.11/16.....	UCPX-1.7/8.....	9.4	UELPL-9/16.....	1.8	UELPL-2.15/16.....	19.4
UCP-1.3/4.....	UCPX-1.15/16.....	9.3	UELPL-5/8.....	1.8	UELPL-3.....	19.0
UCP-1.13/16.....	UCPX-2.....	9.1	UELPL-11/16.....	1.5	JELP Series	
UCP-1.7/8.....	UCPX-2.1/16.....	12.9	UELPL-3/4.....	1.8	JELP-1/2.....	1.5
UCP-1.15/16.....	UCPX-2.1/8.....	12.8	UELPL-13/16.....	2.2	JELP-9/16.....	1.5
UCP-2S.....	UCPX-2.3/16.....	12.6	UELPL-7/8.....	2.2	JELP-5/8.....	1.5
UCP-2.....	UCPX-2.1/4.....	12.4	UELPL-15/16.....	2.2	JELP-11/16.....	1.5
UCP-2.1/16.....	UCPX-2.7/16.....	16.0	UELPL-1.....	2.2	JELP-3/4.....	1.8
UCP-2.1/8.....	UCPX-2.1/2.....	15.9	UELPL-1.1/16.....	3.5	JELP-13/16.....	1.8
UCP-2.3/16.....	UCPX-2.9/16.....	16.7	UELPL-1.1/8.....	3.5	JELP-7/8.....	2.0
UCP-2.1/4.....	UCPX-2.5/8.....	26.2	UELPL-1.3/16.....	3.3	JELP-15/16.....	2.0
UCP-2.5/16.....	UCPX-2.11/16.....	26.0	UELPL-1.1/4S.....	3.3	JELP-1.....	2.0
UCP-2.3/8.....	UCPX-2.3/4.....	25.7	UELPL-1.1/4.....	4.4	JELP-1.1/16.....	3.3
UCP-2.7/16.....	UCPX-2.13/16.....	26.0	UELPL-1.5/16.....	4.4	JELP-1.1/8.....	3.3
UCP-2.1/2.....	UCPX-2.7/8.....	25.7	UELPL-1.3/8.....	4.2	JELP-1.3/16.....	3.3
UCP-2.9/16.....	UCPX-2.15/16.....	25.4	UELPL-1.7/16.....	4.2	JELP-1.1/4S.....	3.3
UCP-2.5/8R.....	UCPX-3.....	25.2	UELPL-1.1/2.....	5.3	JELP-1.1/4.....	4.2
UCP-2.11/16R.....	UCPX-3.3/16.....	39.4	UELPL-1.9/16.....	5.3	JELP-1.5/16.....	4.2
UCP-2.3/4R.....	UCPX-3.7/16.....	40.1	UELPL-1.5/8.....	6.0	JELP-1.3/8.....	4.0
UCP-2.13/16.....	UCPX-3.1/2.....	39.7	UELPL-1.11/16.....	6.0	JELP-1.7/16.....	4.0
UCP-2.7/8.....	ARP Series		UELPL-1.3/4.....	6.0	JELP-1.1/2.....	4.9
UCP-2.15/16.....	ARP-1/2.....	1.5	UELPL-1.13/16.....	7.9	JELP-1.9/16.....	4.9
UCP-3.....	ARP-9/16.....	1.5	UELPL-1.7/8.....	7.9	JELP-1.5/8.....	6.0
UCPL Series	ARP-5/8.....	1.5	UELPL-1.15/16.....	7.7	JELP-1.11/16.....	5.7
UCPL-1/2.....	ARP-11/16.....	1.5	UELPL-2S.....	7.5	JELP-1.3/4.....	5.7
UCPL-9/16.....	ARP-3/4.....	1.5	UELPL-2.....	9.7	JELP-1.13/16.....	7.5
UCPL-5/8.....	ARP-13/16.....	2.0	UELPL-2.1/16.....	9.7	JELP-1.7/8.....	7.5
UCPL-11/16.....	ARP-7/8.....	2.0	UELPL-2.1/8.....	9.5	JELP-1.15/16.....	7.3
UCPL-3/4.....	ARP-15/16.....	2.0	UELPL-2.3/16.....	9.5	JELP-2S.....	7.3
UCPL-13/16.....	ARP-1.....	2.0	UELPL-2.1/4.....	13.0	JELP-2S.....	9.3
UCPL-7/8.....	ARP-1.1/16.....	3.3	UELPL-2.5/16.....	13.0	JELP-2.1/16.....	9.3
UCPL-15/16.....	ARP-1.1/8.....	3.1	UELPL-2.3/8.....	12.8	JELP-2.1/8.....	9.0
UCPL-1.....	ARP-1.1/16.....	3.1	UELPL-2.7/16.....	12.6	JELP-2.3/16.....	9.0
UCPL-1.1/16.....	ARP-1.3/16.....	3.1	UELPL-2.1/2.....	16.3	JELPL Series	
UCPL-1.1/8.....	ARP-1.1/4S.....	3.1	UELPL-2.9/16.....	16.1	JELPL-1/2.....	1.5
UCPL-1.3/16.....	ARP-1.1/4.....	4.0	UELPL-2.5/8R.....	17.4	JELPL-9/16.....	1.5
UCPL-1.1/4S.....	ARP-1.5/16.....	4.0	UELPL-2.11/16R.....	17.2	JELPL-5/8.....	1.5
UCPL-1.1/4.....	ARP-1.3/8.....	3.7	UELPL-2.3/4R.....	16.9	JELPL-11/16.....	1.5
UCPL-1.5/16.....	ARP-1.7/16.....	3.7	UELPL-2.13/16.....	19.4	JELPL-3/4.....	1.8
UCPL-1.3/8.....	ARP-1.1/2.....	4.6	UELPL-2.7/8.....	19.2	JELPL-13/16.....	2.0
UCPL-1.7/16.....	ARP-1.9/16.....	4.6	UELPL-2.15/16.....	19.0	JELPL-7/8.....	2.0
UCPL-1.1/2.....	ARP-1.5/8.....	5.5	UELPL-3.....	18.5	JELPL-15/16.....	2.0
UCPL-1.9/16.....	ARP-1.11/16.....	5.5	UELPL Series		JELPL-1.....	2.0
UCPL-1.9/16.....	ARP-1.3/4.....	5.3	UELPL-1/2.....	1.8	JELPL-1.1/16.....	3.3
UCPL-1.5/8.....	ARP-1.13/16.....	7.3	UELPL-9/16.....	1.8	JELPL-1.1/8.....	3.1
UCPL-1.11/16.....	ARP-1.7/8.....	7.3	UELPL-5/8.....	1.8	JELPL-1.3/16.....	3.1
UCPL-1.3/4.....	ARP-1.15/16.....	7.1	UELPL-11/16.....	1.5	JELPL-1.1/4S.....	3.1
UCPL-1.13/16.....	ARP-2S.....	7.1	UELPL-3/4.....	1.8	JELPL-1.1/4.....	4.0
UCPL-1.7/8.....	ARP-2S.....	8.8	UELPL-13/16.....	2.2	JELPL-1.5/16.....	4.0
UCPL-1.15/16.....	ARP-2.1/16.....	8.8	UELPL-7/8.....	2.2	JELPL-1.3/8.....	4.0
UCPL-2S.....	ARP-2.1/8.....	8.6	UELPL-15/16.....	2.2	JELPL-1.7/16.....	3.7
UCPL-2.....	ARP-2.3/16.....	8.6	UELPL-1.....	2.0	JELPL-1.1/2.....	4.9
UCPL-2.1/16.....	ARPL Series		UELPL-1.1/16.....	3.3	JELPL-1.9/16.....	4.9
UCPL-2.1/8.....	ARPL-1/2.....	1.5	UELPL-1.1/8.....	3.3	JELPL-1.5/8.....	5.7
UCPL-2.3/16.....	ARPL-9/16.....	1.5	UELPL-1.3/16.....	3.3	JELPL-1.11/16.....	5.7
UCPL-2.1/4.....	ARPL-5/8.....	1.5	UELPL-1.1/4S.....	3.3	JELPL-1.3/4.....	5.5
UCPL-2.5/16.....	ARPL-11/16.....	1.5	UELPL-1.1/4.....	4.2	JELPL-1.13/16.....	7.3
UCPL-2.3/8.....	ARPL-3/4.....	1.8	UELPL-1.5/16.....	4.2	JELPL-1.7/8.....	7.3
UCPL-2.7/16.....	ARPL-13/16.....	2.0	UELPL-1.3/8.....	4.2	JELPL-1.15/16.....	7.3
UCPL-2.1/2.....	ARPL-7/8.....	2.0	UELPL-1.7/16.....	4.0	JELPL-2S.....	7.1
UCPL-2.9/16.....	ARPL-15/16.....	2.0	UELPL-1.1/2.....	5.3	JELPL-2S.....	9.3
UCPL-2.5/8.....	ARPL-1.....	2.0	UELPL-1.9/16.....	5.3	JELPL-2.1/16.....	9.0
UCPL-2.11/16.....	ARPL-1.1/16.....	3.1	UELPL-1.5/8.....	6.0		
UCPL-2.3/4.....	ARPL-1.1/8.....	3.1				
UCPL-2.13/16.....						

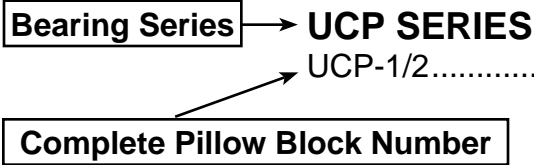

Weight (lbs)

ULTRA-CLASS MOUNTED UNITS **LBS.**

JELPL-2.3/16.....8.8	UCLFU Series	UCFU-1 3/4.....5.3	UELFLU-2S.....6.4
UCFLU-1/2.....0.9	UCFLU-1/2.....0.9	UCFU-1 13/16.....6.2	UELFLU-2.....9.7
UCFLU-9/16.....0.9	UCFLU-9/16.....0.9	UCFU-1 7/8.....6.2	UELFLU-2 1/16.....9.5
UCFLU-5/8.....0.9	UCFLU-5/8.....0.9	UCFU-1 15/16.....6.0	UELFLU-2 1/8.....9.5
UCFLU-11/16.....0.9	UCFLU-11/16.....0.9	UCFU-2S.....6.0	UELFLU-2 3/16.....9.3
UCFLU-3/4.....1.3	UCFLU-3/4.....1.3	UCFU-2.....9.0	UELFLU-2 1/4.....11.7
UCFLU-13/16.....1.5	UCFLU-13/16.....1.3	UCFU-2 1/16.....9.0	UELFLU-2 5/16.....11.5
UCFLU-7/8.....1.5	UCFLU-7/8.....1.8	UCFU-2 1/8.....8.8	UELFLU-2 3/8.....11.2
UCFLU-15/16.....1.5	UCFLU-15/16.....1.8	UCFU-2 3/16.....8.8	UELFLU-2 7/16.....11.2
UCFLU-1.....1.5	UCFLU-1.....1.5	UCFU-2 1/4.....11.0	UELFLU-2 1/2R.....14.4
UCFLU-1 1/16.....2.4	UCFLU-1 1/16.....2.4	UCFU-2 5/16.....10.8	UELFLU-2 9/16R.....14.2
UCFLU-1 1/8.....2.4	UCFLU-1 1/8.....2.4	UCFU-2 3/8.....10.6	UELFLU-2 5/8R.....13.7
UCFLU-1 1/4S.....2.2	UCFLU-1 1/4S.....2.4	UCFU-2 7/16.....10.4	UELFLU-2 11/16R.....13.4
UCFLU-1 1/4.....3.3	UCFLU-1 1/4.....3.5	UCFU-2 1/2R.....12.9	UELFLU-2 3/4R.....14.5
UCFLU-1.5/16.....3.3	UCFLU-1 5/16.....3.5	UCFU-2.9/16R.....12.9	UELFLU-2 13/16.....17.0
UCFLU-1.3/8.....3.1	UCFLU-1 3/8.....3.5	UCFU-2 5/8R.....13.0	UELFLU-2 7/8.....16.8
UCFLU-1.7/16.....3.1	UCFLU-1 7/16.....3.3	UCFU-2 11/16R.....12.8	UELFLU-2 15/16.....16.5
UCFLU-1.1/2.....4.2	UCFLU-1 1/2.....4.4	UCFU-2 3/4R.....14.0	UELFLU-3.....16.1
UCFLU-1.9/16.....4.0	UCFLU-1 9/16.....4.4	UCFU-2 13/16.....16.3	ARFU Series
UCFLU-1.5/8.....4.6	UCFLU-1 5/8.....5.1	UCFU-2 7/8.....16.1	ARFU-1/2.....1.3
UCFLU-1.11/16.....4.6	UCFLU-1 11/16.....4.9	UCFU-2 15/16.....15.9	ARFU-9/16.....1.3
UCFLU-1.3/4.....4.6	UCFLU-1 3/4.....4.9	UCFU-3.....15.7	ARFU-5/8.....1.3
UCFLU-1.13/16.....5.5	UCFLU-1 13/16.....6.0	UCFUX Series	ARFU-11/16.....1.3
UCFLU-1.7/8.....5.5	UCFLU-1 7/8.....6.0	UCFUX-13/16.....3.0	ARFU-3/4.....1.5
UCFLU-1.15/16.....5.3	UCFLU-1 15/16.....5.7	UCFUX-7/8.....2.9	ARFU-13/16.....2.0
UCFLU-2S.....5.3	UCFLU-2.....8.4	UCFUX-15/16.....2.9	ARFU-7/8.....2.0
UCFLU-2.....7.7	UCFLU-2 1/16.....8.2	UCFUX-1.....2.8	ARFU-15/16.....2.0
UCFLU-2 1/16.....7.7	UCFLU-2 1/8.....8.2	UCFUX-1 1/16.....4.3	ARFU-1.....2.0
UCFLU-2 1/8.....7.5	UCFLU-2 3/16.....7.9	UCFUX-1 1/8.....4.2	ARFU-1.1/16.....2.6
UCFLU-2.3/16.....7.5	JELFLU Series	UCFUX-1 3/16.....4.2	ARFU-1.1/8.....2.6
UCFLUX Series	JELFLU-1/2.....0.9	UCFUX-1 1/4.....4.1	ARFU-1.3/16.....2.6
UCFLUX-13/16.....2.4	JELFLU-9/16.....0.9	UCFUX-1 5/16.....4.9	ARFU-1.1/4S.....2.6
UCFLUX-7/8.....2.4	JELFLU-5/8.....0.9	UCFUX-1 3/8.....4.8	ARFU-1.1/4.....3.7
UCFLUX-15/16.....2.3	JELFLU-11/16.....0.9	UCFUX-1 7/16.....4.7	ARFU-1.5/16.....3.5
UCFLUX-1.....2.3	JELFLU-3/4.....1.1	UCFUX-1 1/2.....5.5	ARFU-1.3/8.....3.5
UCFLUX-1 1/16.....3.4	JELFLU-13/16.....1.5	UCFUX-1 9/16.....5.4	ARFU-1.7/16.....3.3
UCFLUX-1 1/8.....3.3	JELFLU-7/8.....1.5	UCFUX-1 5/8.....6.7	ARFU-1.1/2.....4.2
UCFLUX-1 3/16.....3.3	JELFLU-15/16.....1.5	UCFUX-1 11/16.....6.7	ARFU-1.9/16.....4.0
UCFLUX-1 1/4.....3.2	JELFLU-1.....1.5	UCFUX-1 3/4.....6.6	ARFU-1.5/8.....5.3
UCFLUX-1 5/16.....4.3	JELFLU-1 1/16.....2.4	UCFUX-1 13/16.....6.4	ARFU-1.11/16.....5.1
UCFLUX-1 3/8.....4.2	JELFLU-1 1/8.....2.2	UCFUX-1 7/8.....8.6	ARFU-1.3/4.....5.1
UCFLUX-1 7/16.....4.1	JELFLU-1 1/4S.....2.2	UCFUX-1 15/16.....8.5	ARFU-1.13/16.....6.0
UCFLUX-1 1/2.....4.9	JELFLU-1.1/8.....2.2	UCFUX-2.....8.4	ARFU-1.7/8.....6.0
UCFLUX-1 9/16.....4.8	JELFLU-1.3/16.....2.2	UCFUX-2 1/16.....10.5	ARFU-1.15/16.....5.7
UCFLUX-1 5/8.....5.7	JELFLU-1.1/4S.....2.2	UCFUX-2 1/8.....10.4	ARFU-2S.....5.7
UCFLUX-1 11/16.....5.6	JELFLU-1.1/4.....3.3	UCFUX-2 3/16.....10.3	ARFU-1.....8.8
UCFLUX-1 3/4.....5.5	JELFLU-1.5/16.....3.3	UCFUX-2 1/4.....10.0	ARFU-1.1/16.....8.6
UCFLUX-1 13/16.....5.4	JELFLU-1.3/8.....3.3	UCFUX-2 5/16.....9.9	ARFU-2.1/8.....8.6
UCFLUX-1 7/8.....8.2	JELFLU-1.7/16.....3.1	UCFUX-2 7/16.....15.0	ARFU-2.3/16.....8.4
UCFLUX-1 15/16.....8.0	JELFLU-1.1/2.....4.2	UCFUX-2 1/2.....14.9	JELFU Series
UCFLUX-2.....7.9	JELFLU-1.1/2.....4.2	UCFUX-2 9/16.....14.7	JELFU-1/2.....1.3
ARFLU Series	JELFLU-1.9/16.....4.0	UCFUX-2 5/8.....15.7	JELFU-9/16.....1.3
ARFLU-1/2.....0.9	JELFLU-1.5/8.....4.9	UCFUX-2 11/16.....15.5	JELFU-5/8.....1.3
ARFLU-9/16.....0.9	JELFLU-1.11/16.....4.9	UCFUX-2 3/4.....15.3	JELFU-11/16.....1.3
ARFLU-5/8.....0.9	JELFLU-1.3/4.....4.6	UCFUX-2 13/16.....16.4	JELFU-3/4.....1.5
ARFLU-11/16.....0.9	JELFLU-1.13/16.....5.5	UCFUX-2 7/8.....16.1	JELFU-13/16.....2.0
ARFLU-3/4.....1.1	JELFLU-1.7/8.....5.5	UCFUX-2 15/16.....15.9	JELFU-7/8.....2.0
ARFLU-13/16.....1.5	JELFLU-1.15/16.....5.5	UCFUX-3.....15.6	JELFU-15/16.....2.0
ARFLU-7/8.....1.5	JELFLU-2S.....5.3	UELFLU Series	JELFU-1.....2.0
ARFLU-15/16.....1.5	JELFLU-2S.....7.9	UELFLU-1/2.....1.5	JELFU-1.1/16.....2.9
ARFLU-1.....1.5	JELFLU-2.1/16.....7.7	UELFLU-9/16.....1.5	JELFU-1.1/8.....2.6
ARFLU-1.1/16.....2.2	JELFLU-2.1/8.....7.7	UELFLU-5/8.....1.5	JELFU-1.3/16.....2.6
ARFLU-1.1/8.....2.2	JELFLU-2.3/16.....7.5	UELFLU-11/16.....1.3	JELFU-1.3/8.....3.7
ARFLU-1.3/16.....2.2	UCFU Series	UELFLU-3/4.....1.8	JELFU-1.7/16.....3.7
ARFLU-1.1/4S.....2.2	UCFU-1/2.....1.3	UELFLU-13/16.....2.2	JELFU-1.1/4S.....2.6
ARFLU-1.1/4.....3.3	UCFU-9/16.....1.3	UELFLU-7/8.....2.2	JELFU-1.1/4.....3.7
ARFLU-1.5/16.....3.1	UCFU-5/8.....1.3	UELFLU-15/16.....2.0	JELFU-1.5/16.....3.7
ARFLU-1.3/8.....2.9	UCFU-11/16.....1.3	UELFLU-1.....2.0	JELFU-1.7/16.....3.7
ARFLU-1.7/16.....2.9	UCFU-3/4.....1.8	UELFLU-1 1/16.....2.9	JELFU-1.1/2.....4.4
ARFLU-1.1/2.....3.7	UCFU-13/16.....2.0	UELFLU-1 1/8.....2.9	JELFU-1.9/16.....4.4
ARFLU-1.9/16.....3.7	UCFU-7/8.....2.0	UELFLU-1 3/16.....2.9	JELFU-1.5/8.....5.5
ARFLU-1.5/8.....4.4	UCFU-15/16.....2.0	UELFLU-1 1/4S.....2.9	JELFU-1.11/16.....5.5
ARFLU-1.11/16.....4.4	UCFU-1.....2.0	UELFLU-1 1/4.....4.0	JELFU-1.3/4.....5.3
ARFLU-1.3/4.....4.4	UCFU-1 1/8.....2.9	UELFLU-1 5/16.....4.0	JELFU-1.13/16.....6.2
ARFLU-1.13/16.....5.3	UCFU-1 1/16.....2.9	UELFLU-1 3/8.....4.0	JELFU-1.7/8.....6.2
ARFLU-1.7/8.....5.3	UCFU-1 1/4.....3.7	UELFLU-1 7/16.....4.0	JELFU-1.15/16.....6.2
ARFLU-1.15/16.....5.1	UCFU-1 3/8.....3.7	UELFLU-1 1/2.....4.9	JELFU-2S.....6.0
ARFLU-2S.....5.1	UCFU-1 7/16.....3.5	UELFLU-1 1/2.....4.9	JELFU-2S.....9.3
ARFLU-2S.....7.5	UCFU-1 1/2.....4.4	UELFLU-1 9/16.....4.6	JELFU-1.....9.0
ARFLU-2.1/16.....7.3	UCFU-1 9/16.....4.4	UELFLU-1 5/8.....5.7	JELFU-2.1/8.....9.0
ARFLU-2.1/8.....7.3	UCFU-1 5/8.....5.5	UELFLU-1 11/16.....5.5	JELFU-2.3/16.....8.8
ARFLU-2.3/16.....7.1	UCFU-1 11/16.....5.3	UELFLU-1 3/4.....5.5	
		UELFLU-1 13/16.....6.6	
		UELFLU-1 7/8.....6.6	
		UELFLU-1 15/16.....6.4	



Units: Millimeters
INCHES

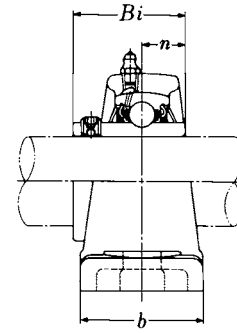
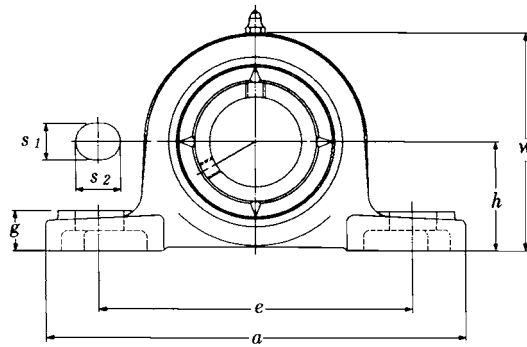

PILLOW BLOCKS - CAST HOUSING

Shaft Dia.	Complete Pillow Block Number	Nominal Dimensions										Bolt Size	Housing Number	Bearing Number	Basic Load Ratings (lbs)	
		<i>h</i>	<i>a</i>	<i>e</i>	<i>b</i>	<i>s₁</i>	<i>s₂</i>	<i>g</i>	<i>w</i>	<i>Bi</i>	<i>n</i>				<i>C_d</i>	<i>C_s</i>
12 ½	UCP201D1 UCP201-008D1	30.2 1 ¾	127 5	95 3 ¾	38 1 ½	13 ½	16 ⅝	14 ⅞	62 2 ⅞	31 1.220	12.7 .500	M10 ⅝	P203D1 P203D1	UC201D1 UC201-008D1	2,890	1,500
15 9/16 5/8	UCP202D1 UCP202-009D1 UCP202-010D1	30.2 1 ¾	127 5	95 3 ¾	38 1 ½	13 ½	16 ⅝	14 ⅞	62 2 ⅞	31 1.220	12.7 .500	M10 ⅝	P203D1 P203D1 P203D1	UC202D1 UC202-009D1 UC202-010D1	2,890	1,500
17 1 1/16	UCP203D1 UCP203-011D1	30.2 1 ¾	127 5	95 3 ¾	38 1 ½	13 ½	16 ⅝	14 ⅞	62 2 ⅞	31 1.220	12.7 .500	M10 ⅝	P203D1 P203D1	UC203D1 UC203-011D1	2,890	1,500
20 ¾	UCP204D1 UCP204-012D1	33.3 1 ⅝	127 5	95 3 ¾	38 1 ½	13 ½	16 ⅝	14 ⅞	65 2 9/16	31 1.220	12.7 .500	M10 ⅝	P204D1 P204D1	UC204D1 UC204-012D1	2,890	1,500
25 1 3/16 7/8 1 1/16 1	UCP205D1 UCP205-013D1 UCP205-014D1 UCP205-015D1 UCP205-100D1	36.5 1 7/16	140 5 ½	105 4 ⅞	38 1 ½	13 ½	16 ⅝	15 19/32	71 2 25/32	34 1.339	14.3 .563	M10 ⅝	P205D1 P205D1 P205D1 P205D1	UC205D1 UC205-013D1 UC205-014D1 UC205-015D1 UC205-100D1	3,150	1,770
30 1 1/16 1 1/8 1 3/16 1 1/4	UCP206D1 UCP206-101D1 UCP206-102D1 UCP206-103D1 UCP206-104D1	42.9 1 11/16	165 6 ½	121 4 ¾	48 1 7/8	17 21/32	20 25/32	17 21/32	83 3 3/32	38.1 1.500	15.9 .626	M14 ½	P206D1 P206D1 P206D1 P206D1	UC206D1 UC206-101D1 UC206-102D1 UC206-103D1 UC206-104D1	4,400	2,540
35 1 1/4 1 5/16 1 3/8 1 7/16	UCP207D1 UCP207-104D1 UCP207-105D1 UCP207-106D1 UCP207-107D1	47.6 1 7/8	167 6 9/16	127 5	48 1 7/8	17 21/32	20 25/32	18 23/32	93 3 21/32	42.9 1.689	17.5 .689	M14 ½	P207D1 P207D1 P207D1 P207D1	UC207D1 UC207-104D1 UC207-105D1 UC207-106D1 UC207-107D1	5,750	3,440
40 1 1/2 1 9/16	UCP208D1 UCP208-108D1 UCP208-109D1	49.2 1 15/16	184 7 ¼	137 5 13/32	54 2 1/8	17 21/32	20 25/32	18 23/32	98 3 27/32	49.2 1.937	19 .748	M14 ½	P208D1 P208D1	UC208D1 UC208-108D1 UC208-109D1	6,550	4,000
45 1 5/8 1 11/16 1 3/4	UCP209D1 UCP209-110D1 UCP209-111D1 UCP209-112D1	54 2 1/8	190 7 15/32	146 5 ¾	54 2 1/8	17 21/32	20 25/32	20 25/32	106 4 3/16	49.2 1.937	19 .748	M14 ½	P209D1 P209D1 P209D1	UC209D1 UC209-110D1 UC209-111D1 UC209-112D1	7,350	4,590
50 1 13/16 1 7/8 1 15/16 2	UCP210D1 UCP210-113D1 UCP210-114D1 UCP210-115D1 UCP210-200D1	57.2 2 ¼	206 8 1/8	159 6 ¼	60 2 3/8	20 25/32	23 29/32	21 13/16	114 4 ½	51.6 2.031	19 .748	M16 5/8	P210D1 P210D1 P210D1 P210D1	UC210D1 UC210-113D1 UC210-114D1 UC210-115D1 UC210-200D1	7,900	5,220
55 2 2 1/16 2 1/8 2 3/16	UCP211D1 UCP211-200D1 UCP211-201D1 UCP211-202D1 UCP211-203D1	63.5 2 ½	219 8 5/8	171 6 23/32	60 2 3/8	20 25/32	23 29/32	23 29/32	126 4 31/32	55.6 2.189	22.2 .874	M16 5/8	P211D1 P211D1 P211D1 P211D1	UC211D1 UC211-200D1 UC211-201D1 UC211-202D1 UC211-203D1	9,750	6,570
60 2 1/4 2 3/8 2 7/16	UCP212D1 UCP212-204D1 UCP212-206D1 UCP212-207D1	69.8 2 ¾	241 9 ½	184 7 ¼	70 2 ¾	20 25/32	23 29/32	25 31/32	138 5 7/16	65.1 2.563	25.4 1.000	M16 5/8	P212D1 P212D1 P212D1	UC212D1 UC212-204D1 UC212-206D1 UC212-207D1	11,800	8,100

Continued next page ...

Units: Millimeters
INCHES

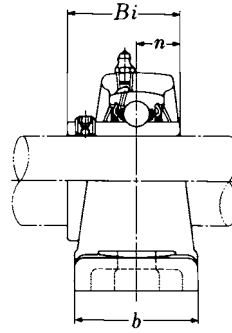
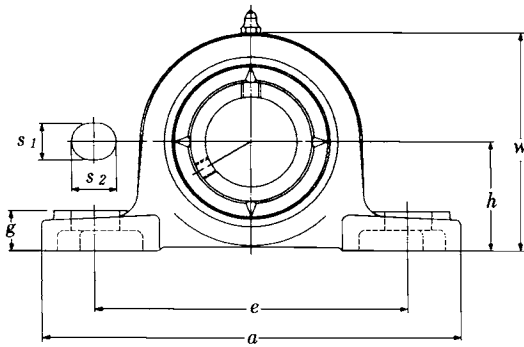

PILLOW BLOCKS - CAST HOUSING

Shaft Dia.	Complete Pillow Block Number	Nominal Dimensions										Bolt Size	Housing Number	Bearing Number	Basic Load Ratings (lbs)	
		h	a	e	b	s ₁	s ₂	g	w	Bi	n				Dynamic C	Static C ₀
65 2 1/2	UCP213D1 UCP213-208D1	76.2 3	265 10 7/16	203 8	70 2 3/4	25 3 1/32	28 1 3/32	27 1 1/16	151 5 15/16	65.1 2.563	25.4 1.000	M20 3/4	P213D1 P213D1	UC213D1 UC213-208D1	12,900	9,000
70 2 11/16 2 3/4	UCP214D1 UCP214-211D1 UCP214-212D1	79.4 3 1/8	266 10 15/32	210 8 9/32	72 2 27/32	25 3 1/32	28 1 3/32	27 1 1/16	157 6 3/16	74.6 2.937	30.2 1.189	M20 3/4	P214D1 P214D1 P214D1	UC214D1 UC214-211D1 UC214-211D1	14,000	9,900
75 2 15/16 3	UCP215D1 UCP215-215D1 UCP215-300D1	82.6 3 1/4	275 10 13/16	217 8 17/32	74 2 29/32	25 3 1/32	28 1 3/32	28 1 3/32	163 6 13/32	77.8 3.063	33.3 1.311	M20 3/4	P215D1 P215D1 P215D1	UC215D1 UC215-215D1 UC215-300D1	14,900	11,100
80 3 1/8	UCP216D1 UCP216-302D1	88.9 3 1/2	292 11 1/2	232 9 1/8	78 3 1/16	25 3 1/32	28 1 3/32	30 1 3/16	175 6 7/8	82.6 3.252	33.3 1.311	M20 3/4	P216D1 P216D1	UC216D1 UC216-302D1	16,300	11,900
85 3 1/4	UCP217D1 UCP217-304D1	95.2 3 3/4	310 12 7/32	247 9 23/32	83 3 9/32	25 3 1/32	28 1 3/32	32 1 1/4	187 7 3/8	85.7 3.374	34.1 1.343	M20 3/4	P217D1 P217D1	UC217D1 UC217-304D1	18,700	14,400
90 3 1/2	UCP218D1 UCP218-308D1	101.6 4	327 12 7/8	262 10 5/16	88 3 15/32	27 1 1/16	30 1 3/16	33 1 5/16	200 7 7/8	96 3.780	39.7 1.563	M22 7/8	P218D1 P218D1	UC218D1 UC218-308D1	21,600	16,100



Units: Millimeters
INCHES

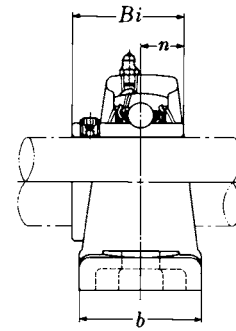
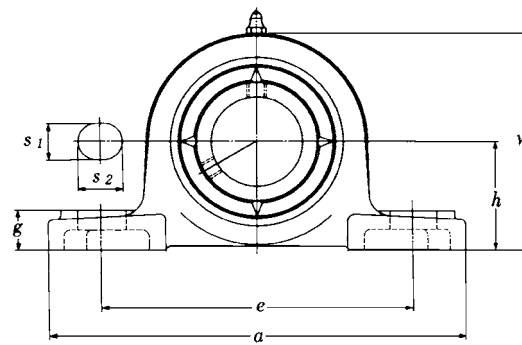

PILLOW BLOCKS - CAST HOUSING (LOW CENTER HEIGHT)																
Shaft Dia.	Complete Pillow Block Number	Nominal Dimensions										Bolt Size	Housing Number	Bearing Number	Basic Load Ratings (lbs)	
		<i>h</i>	<i>a</i>	<i>e</i>	<i>b</i>	<i>s₁</i>	<i>s₂</i>	<i>g</i>	<i>w</i>	<i>Bi</i>	<i>n</i>				<i>C</i>	<i>C₀</i>
20 3/4	UCPL204D1 UCPL204-012D1	31.75 1 1/4	127 5	95 3 3/4	38 1 1/2	13 1/2	16 5/8	14 9/16	64 2 17/32	31 1.220	12.7 .500	M10 3/8	PL204D1 PL204D1	UC204D1 UC204-012D1	2,890	1,500
25 13/16 7/8 15/16 1	UCPL205D1 UCPL205-013D1 UCPL205-014D1 UCPL205-015D1 UCPL205-100D1	33.34 1 5/16	140 5 1/2	105 4 1/8	38 1 1/2	13 1/2	16 5/8	15 19/32	68 2 11/16	34 1.339	14.3 .563	M10 3/8	PL205D1 PL205D1 PL205D1 PL205D1 PL205D1	UC205D1 UC205-013D1 UC205-014D1 UC205-015D1 UC205-100D1	3,150	1,770
30 1 1/16 1 1/8 1 3/16 1 1/4	UCPL206D1 UCPL206-101D1 UCPL206-102D1 UCPL206-103D1 UCPL206-104D1	39.69 1 9/16	165 6 1/2	121 4 3/4	48 1 7/8	17 21/32	20 25/32	17 21/32	80 3 5/32	38.1 1.500	15.9 .626	M14 1/2	PL206D1 PL206D1 PL206D1 PL206D1 PL206D1	UC206D1 UC206-101D1 UC206-102D1 UC206-103D1 UC206-104D1	4,400	2,540
35 1 1/4 1 5/16 1 3/8 1 7/16	UCPL207D1 UCPL207-104D1 UCPL207-105D1 UCPL207-106D1 UCPL207-107D1	46.04 1 13/16	167 6 5/16	127 5	48 1 7/8	17 21/32	20 25/32	18 23/32	91 3 19/32	42.9 1.689	17.5 .689	M14 1/2	PL207D1 PL207D1 PL207D1 PL207D1 PL207D1	UC207D1 UC207-104D1 UC207-105D1 UC207-106D1 UC207-107D1	5,750	3,440
45 1 5/8 1 11/16 1 3/4	UCPL209D1 UCPL209-110D1 UCPL209-111D1 UCPL209-112D1	52.39 2 1/16	190 7 15/32	146 5 3/4	54 2 1/8	17 21/32	20 25/32	20 25/32	104 4 3/32	49.2 1.937	19 .748	M14 1/2	PL209D1 PL209D1 PL209D1 PL209D1	UC209D1 UC209-110D1 UC209-111D1 UC209-112D1	7,350	4,590
50 1 13/16 1 7/8 1 15/16 2	UCPL210D1 UCPL210-113D1 UCPL210-114D1 UCPL210-115D1 UCPL210-200D1	55.56 2 3/16	206 8 1/8	159 6 1/4	60 2 3/8	20 25/32	23 29/32	21 13/16	112 4 13/32	51.6 2.031	19 .748	M16 5/8	PL210D1 PL210D1 PL210D1 PL210D1 PL210D1	UC210D1 UC210-113D1 UC210-114D1 UC210-115D1 UC210-200D1	7,900	5,220

Note: These numbers indicate relubricatable type. If maintenance free type is needed, please order without suffix D1
UCPL204 and UCPL205 have solid bases.
UCPL208 has the same dimensions as UCP208 shown on page 156

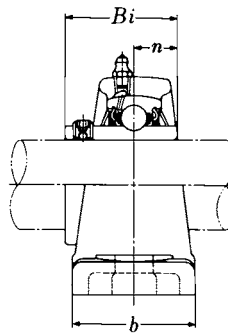
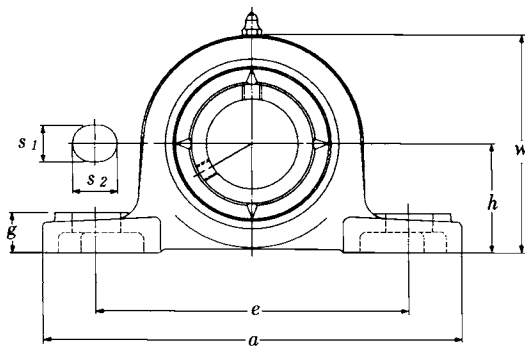

Units: Millimeters
INCHES



PILLOW BLOCKS - CAST HOUSING

Shaft Dia.	Complete Pillow Block Number	Nominal Dimensions										Bolt Size	Housing Number	Bearing Number	Basic Load Ratings (lbs)	
		h	a	e	b	s ₁	s ₂	g	w	Bi	n				Dynamic C	Static C ₀
25 7/8 15/16 1	UCP305D1 UCP305-014D1 UCP305-015D1 UCP305-100D1	45 1 25/32	175 6 7/8	132 5 3/16	45 1 25/32	17 2 1/32	20 25/32	15 19/32	85 3 11/32	38 1.496	15 .591	M14 1/2	P305D1 P305D1 P305D1 P305D1	UC305D1 UC305-014D1 UC305-015D1 UC305-100D1	4,750	2,460
30 1 1/8 1 3/16	UCP306D1 UCP306-102D1 UCP306-103D1	50 1 31/32	180 7 3/32	140 5 1/2	50 1 31/32	17 2 1/32	20 25/32	18 23/32	95 3 3/4	43 1.693	17 .669	M14 1/2	P306D1 P306D1 P306D1	UC306D1 UC306-102D1 UC306-102D1	6,000	3,400
35 1 1/4 1 5/16 1 3/8 1 7/16	UCP307D1 UCP307-104D1 UCP307-105D1 UCP307-106D1 UCP307-107D1	56 2 7/32	210 8 9/32	160 6 5/16	56 2 7/32	17 2 1/32	25 3 1/32	20 25/32	106 4 3/16	48 1.890	19 .748	M14 1/2	P307D1 P307D1 P307D1 P307D1 P307D1	UC307D1 UC307-104D1 UC307-105D1 UC307-106D1 UC307-107D1	7,500	4,300
40 1 1/2	UCP308D1 UCP308-108D1	60 2 3/8	220 8 21/32	170 6 11/16	60 2 3/8	17 2 1/32	27 1 1/16	22 7/8	116 4 9/16	52 2.047	19 .748	M14 1/2	P308D1 P308D1	UC308D1 UC308-108D1	9,150	5,400
45 1 5/8 1 11/16 1 3/4	UCP309D1 UCP309-110D1 UCP309-111D1 UCP309-112D1	67 2 5/8	245 9 2 1/32	190 7 15/32	67 2 5/8	20 25/32	30 1 3/16	24 15/16	129 5 3/32	57 2.244	22 .866	M16 5/8	P309D1 P309D1 P309D1 P309D1	UC309D1 UC309-110D1 UC309-111D1 UC309-112D1	11,900	7,200
50 1 7/8 1 15/16	UCP310D1 UCP310-114D1 UCP310-115D1	75 2 15/16	275 10 13/16	212 8 11/32	75 2 15/16	20 25/32	35 1 3/8	27 1 1/16	143 5 5/8	61 2.402	22 .866	M16 5/8	P310D1 P310D1 P310D1	UC310D1 UC310-114D1 UC310-115D1	13,900	8,660
55 2 2 1/8 2 3/16	UCP311D1 UCP311-200D1 UCP311-202D1 UCP311-203D1	80 3 5/32	310 12 7/32	236 9 9/32	80 3 5/32	20 25/32	38 1 1/2	30 1 3/16	154 6 1/16	66 2.598	25 .984	M16 5/8	P311D1 P311D1 P311D1 P311D1	UC311D1 UC311-200D1 UC311-202D1 UC311-203D1	16,100	10,100
60 2 1/4 2 3/8 2 7/16	UCP312D1 UCP312-204D1 UCP312-206D1 UCP312-207D1	85 3 1 1/32	330 13	250 9 27/32	85 3 1 1/32	25 3 1/32	38 1 1/2	32 1 1/4	165 6 1/2	71 2.795	26 1.024	M20 3/4	P312D1 P312D1 P312D1 P312D1	UC312D1 UC312-204D1 UC312-206D1 UC312-207D1	18,400	11,700
65 2 1/2	UCP313D1 UCP313-208D1	90 3 17/32	340 13 3/8	260 10 1/4	90 3 17/32	25 3 1/32	38 1 1/2	33 1 5/16	176 6 15/16	75 2.953	30 1.181	M20 3/4	P313D1 P313D1	UC313D1 UC313-208D1	20,800	13,400
70 2 11/16 2 3/4	UCP314D1 UCP314-211D1 UCP314-212D1	95 3 3/4	360 14 3/16	280 11 1/32	90 3 17/32	27 1 1/16	40 1 9/16	35 1 3/8	187 7 3/8	78 3.071	33 1.299	M22 7/8	P314D1 P314D1 P314D1	UC314D1 UC314-211D1 UC314-212D1	23,400	15,300
75 2 15/16 3	UCP315D1 UCP315-215D1 UCP315-300D1	100 3 15/16	380 14 3 1/32	290 11 13/32	100 3 15/16	27 1 1/16	40 1 9/16	35 1 3/8	198 7 25/32	82 3.228	32 1.260	M22 7/8	P315D1 P315D1 P315D1	UC315D1 UC315-215D1 UC315-215D1	25,500	17,400
80 3 1/8 3 3/16	UCP316D1 UCP316-302D1 UCP316-303D1	106 4 3/16	400 15 3/4	300 11 13/16	110 4 1 1/32	27 1 1/16	40 1 9/16	40 1 9/16	210 8 9/32	86 3.386	34 1.339	M22 7/8	P316D1 P316D1 P316D1	UC316D1 UC316-302D1 UC316-303D1	27,600	19,500
85 3 3/4	UCP317D1 UCP317-304D1	112 4 13/32	420 16 17/32	320 12 19/32	110 4 1 1/32	33 1 5/16	45 1 25/32	40 1 9/16	220 8 2 1/32	96 3.780	40 1.575	M27 1	P317D1 P317D1	UC317D1 UC317-304D1	29,800	21,800
90 3 7/16 3 1/2	UCP318D1 UCP318-307D1 UCP318-308D1	118 4 2 1/32	430 16 15/16	330 13	110 4 1 1/32	33 1 5/16	45 1 25/32	45 1 25/32	235 9 1/4	96 3.780	40 1.575	M27 1	P318D1 P318D1 P318D1	UC318D1 UC318-307D1 UC318-308D1	32,000	24,100
95 3 3/4	UCP319D1 UCP319-312D1	125 4 29/32	470 18 1/2	360 14 3/16	120 4 23/32	36 1 13/32	50 1 3 1/32	45 1 25/32	250 9 27/32	103 4.055	41 1.614	M30 1 1/8	P319D1 P319D1	UC319D1 UC319-312D1	34,500	26,600
100 3 15/16 4	UCP320D1 UCP320-315D1 UCP320-400D1	140 5 1/2	490 19 9/32	380 14 3 1/32	120 4 23/32	36 1 13/32	50 1 3 1/32	50 1 3 1/32	275 10 13/16	108 4.252	42 1.654	M30 1 1/8	P320D1 P320D1 P320D1	UC320D1 UC320-315D1 UC320-400D1	39,000	31,500
105	UCP321D1	140	490	380	120	36	50	50	280	112	44	M30	P321D1	UC321D1	41,400	34,500
110	UCP322D1	150	520	400	140	40	55	55	300	117	46	M33	P322D1	UC322D1	46,100	40,500
120	UCP324D1	160	570	450	140	40	55	65	320	126	51	M33	P324D1	UC324D1	46,600	41,500
130	UCP326D1	180	600	480	140	40	55	75	355	135	54	M33	P326D1	UC326D1	51,500	48,000
140	UCP328D1	200	620	500	140	40	55	75	390	145	59	M33	P328D1	UC328D1	56,900	55,500

NTN
SERIES
UCPX
SET SCREW
TYPE

Units: Millimeters
 INCHES

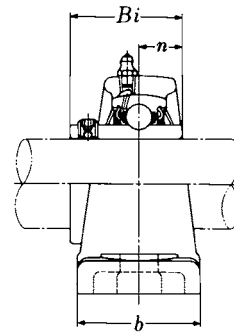
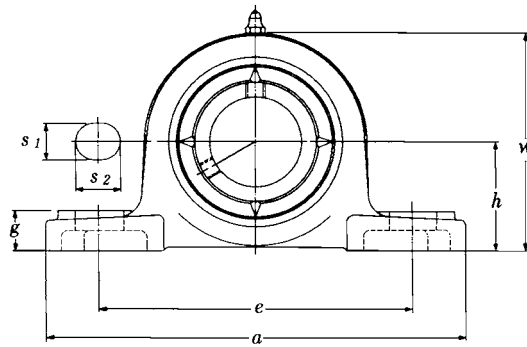

PILLOW BLOCKS - CAST HOUSING

Shaft Dia.	Complete Pillow Block Number	Nominal Dimensions										Bolt Size	Housing Number	Bearing Number	Basic Load Ratings (lbs)	
		h	a	e	b	s ₁	s ₂	g	w	Bi	n				Dynamic C	Static C ₀
25 1 3/16 7/8 15/16 1	UCPX05D1 UCPX05-013D1 UCPX05-014D1 UCPX05-015D1 UCPX05-100D1	44.4 1 3/4	159 6 1/4	119 4 11/16	51 2	17 2 1/32	20 25/32	18 23/32	85 3 11/32	38.1 1.500	15.9 0.626	M14 1/2	PX05D1 PX05D1 PX05D1 PX05D1 PX05D1	UCX05D1 UCX05-013D1 UCX05-014D1 UCX05-015D1 UCX05-100D1	4,390	2,540
30 1 1/16 1 1/8 1 3/16 1 1/4	UCPX06D1 UCPX06-101D1 UCPX06-102D1 UCPX06-103D1 UCPX06-104D1	47.6 1 7/8	175 6 7/8	127 5	57 2 1/4	17 2 1/32	20 25/32	20 25/32	93 3 2 1/32	42.9 1.689	17.5 0.689	M14 1/2	PX06D1 PX06D1 PX06D1 PX06D1 PX06D1	UCX06D1 UCX06-101D1 UCX06-102D1 UCX06-103D1 UC207-104D1	5,780	3,440
35 1 9/16 1 3/8 1 7/16	UCPX07D1 UCPX07-105D1 UCPX07-106D1 UCPX07-107D1	54 2 1/8	203 8	144 5 2 1/32	57 2 1/4	17 2 1/32	20 25/32	21 1 1/16	105 4 1/8	49.2 1.937	19 0.748	M14 1/2	PX07D1 PX07D1 PX07D1 PX07D1	UCX07D1 UCX07-105D1 UCX07-106D1 UCX07-107D1	6,550	4,000
40 1 1/2 1 9/16	UCPX08D1 UCPX08-108D1 UCPX08-109D1	58.7 2 9/16	222 8 3/4	156 6 5/32	67 2 5/8	20 25/32	23 29/32	26 1 1/32	111 4 3/8	49.2 1.937	19 0.748	M16 5/8	PX08D1 PX08D1 PX08D1	UCX08D1 UCX08-108D1 UCX08-109D1	7,310	4,590
45 1 5/8 1 1 1/16 1 3/4 1 13/16	UCPX09D1 UCPX09-110D1 UCPX09-111D1 UCPX09-112D1 UCPX09-113D1	58.7 2 5/16	222 8 3/4	156 6 5/32	67 2 5/8	20 25/32	23 29/32	26 1 1/32	116 4 9/16	51.6 2.031	19 0.748	M16 5/8	PX09D1 PX09D1 PX09D1 PX09D1 PX09D1	UCX09D1 UCX09-110D1 UCX09-111D1 UCX09-112D1 UC210-113D1	7,870	5,220
50 1 7/8 1 15/16 2	UCPX10D1 UCPX10-114D1 UCPX10-115D1 UCPX10-200D1	63.5 2 1/2	241 9 1/2	171 6 29/32	73 2 7/8	20 25/32	23 29/32	27 1 1/16	126 4 3 1/32	55.6 2.189	22.2 0.874	M16 5/8	PX10D1 PX10D1 PX10D1 PX10D1	UCX10D1 UCX10-114D1 UCX10-115D1 UC211-200D1	9,780	6,570
55 2 1/16 2 1/8 2 3/16 2 1/4 2 5/16	UCPX11D1 UCPX11-201D1 UCPX11-202D1 UCPX11-203D1 UCPX11-204D1 UCPX11-205D1	69.8 2 3/4	260 10 1/4	184 7 1/4	79 3 1/8	25 3 1/32	28 1 3/32	30 1 3/16	137 5 1 3/32	65.1 2.563	25.4 1.000	M20 3/4	PX11D1 PX11D1 PX11D1 PX11D1 PX11D1 PX11D1	UCX11D1 UCX11-201D1 UCX11-202D1 UCX11-203D1 UC212-204D1 UC212-205D1	11,810	8,100
60 2 3/8 2 7/16	UCPX12D1 UCPX12-206D1 UCPX12-207D1	76.2 3	286 11 1/4	203 8	83 3 9/32	25 3 1/32	28 1 3/32	33 1 5/16	151 5 15/16	65.1 2.563	25.4 1.000	M20 3/4	PX12D1 PX12D1 PX12D1	UCX12D1 UCX12-206D1 UCX12-207D1	12,930	9,000
65 2 1/2 2 9/16	UCPX13D1 UCPX13-208D1 UCPX13-209D1	76.2 3	286 11 1/4	203 8	83 3 9/32	25 3 1/32	28 1 3/32	33 1 5/16	154 6 1/16	74.6 2.937	30.2 1.189	M20 3/4	PX13D1 PX13D1 PX13D1	UCX13D1 UCX13-208D1 UCX13-209D1	13,940	9,900
70 2 5/8 2 1 1/16 2 3/4	UCPX14D1 UCPX14-210D1 UCPX14-211D1 UCPX14-212D1	88.9 3 1/2	330 13	229 9 1/32	89 3 1/2	27 1 1/16	30 1 3/16	35 1 3/8	170 6 1 1/16	77.8 3.063	33.3 1.311	M22 7/8	PX14D1 PX14D1 PX14D1 PX14D1	UCX14D1 UCX14-210D1 UCX14-211D1 UCX14-212D1	14,840	11,130
75 2 13/16 2 7/8 2 15/16 3	UCPX15D1 UCPX15-213D1 UCPX15-214D1 UCPX15-215D1 UCPX15-300D1	88.9 3 1/2	330 13	229 9 1/32	89 3 1/2	27 1 1/16	30 1 3/16	35 1 3/8	175 6 7/8	82.6 3.252	33.3 1.311	M22 7/8	PX15D1 PX15D1 PX15D1 PX15D1 PX15D1	UCX15D1 UCX15-213D1 UCX15-214D1 UCX15-215D1 UCX15-300D1	16,310	11,920

Continued next page ...

Units: Millimeters
INCHES

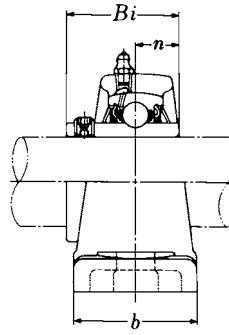
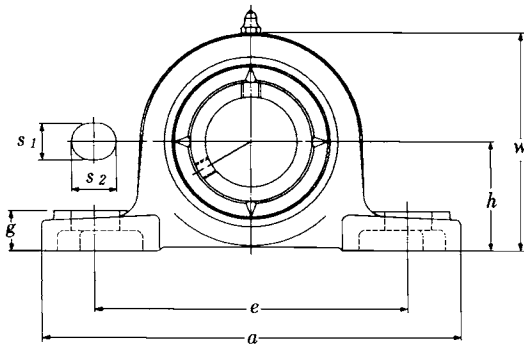
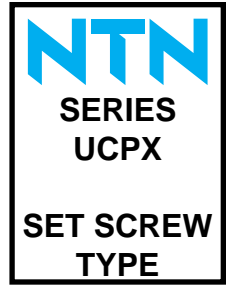

PILLOW BLOCKS - CAST HOUSING

Shaft Dia.	Complete Pillow Block Number	Nominal Dimensions										Bolt Size	Housing Number	Bearing Number	Basic Load Ratings (lbs)	
		h	a	e	b	s ₁	s ₂	g	w	Bi	n				Dynamic C	Static C ₀
80 3 1/8 3 3/16 3 1/4	UCPX16D1 UCPX16-302D1 UCPX16-303D1 UCPX16-304D1	101.6 4	381 15	283 11 5/32	102 4 1/32	27 1 1/16	30 1 3/16	40 1 9/16	194 7 5/8	85.7 3.374	34.1 1.343	M22 7/8	PX16D1 PX16D1 PX16D1 PX16D1	UCX16D1 UCX16-302D1 UCX16-303D1 UC217-304D1	18,780	14,390
85 3 5/16 3 7/16	UCPX17D1 UCPX17-305D1 UCPX17-307D1	101.6 4	381 15	283 11 5/32	102 4 1/32	27 1 1/16	30 1 3/16	40 1 9/16	200 7 7/8	96 3.780	39.7 1.563	M22 7/8	PX17D1 PX17D1 PX17D1	UCX17D1 UCX17-305D1 UCX17-307D1	21,590	16,080
90 3 1/2	UCPX18D1 UCPX18-308D1	101.6 4	381 15	283 11 5/32	111 4 3/8	27 1 1/16	30 1 3/16	40 1 9/16	206 8 1/8	104 4.094	42.9 1.689	M22 7/8	PX18D1 PX18D1	UCX18D1 UCX18-308D1	24,520	18,440
100 3 7/8 3 15/16 4	UCPX20D1 UCPX20-314D1 UCPX20-315D1 UCPX20-400D1	127 5	432 17	337 13 9/32	121 4 3/4	33 1 5/16	36 1 13/32	45 1 25/32	244 9 19/32	117.5 4.626	49.2 1.937	M27 1	PX20D1 PX20D1 PX20D1 PX20D1	UCX20D1 UCX20-314D1 UCX20-315D1 UCX20-400D1	29,910	23,620



Units: Millimeters
INCHES

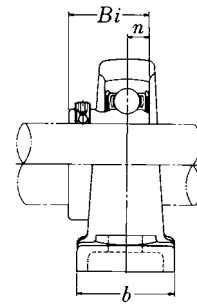
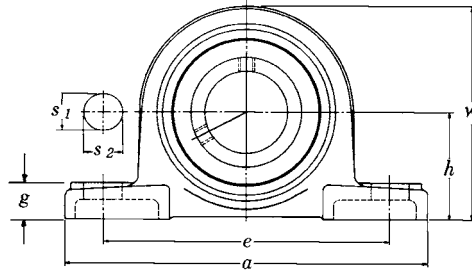

PILLOW BLOCKS - CAST HOUSING (LOW CENTER HEIGHT)																
Shaft Dia.	Complete Pillow Block Number	Nominal Dimensions										Bolt Size	Housing Number	Bearing Number	Basic Load Ratings (lbs)	
		h	a	e	b	s ₁	s ₂	g	w	Bi	n				Dynamic C	Static C ₀
12 ½	ASPL201 ASPL201-008	26.99 1 ¼	121 4 ¾	89 3 ½	35 1 ⅜	11 7/16	14 9/16	13 ½	54 2 ⅛	22 .866	6 .236	M10 ⅜	PL201 PL201	AS201 AS201-008	2,160	1,040
15 9/16 5/8	ASPL202 ASPL202-009 ASPL202-010	26.99 1 ¼	121 4 ¾	89 3 ½	35 1 ⅜	11 7/16	14 9/16	13 ½	54 2 ⅛	22 .866	6 .236	M10 ⅜	PL201 PL201 PL201	AS202 AS202-009 AS202-010	2,160	1,040
17 1 1/16	ASPL203 ASPL203-011	26.99 1 ¼	121 4 ¾	89 3 ½	35 1 ⅜	11 7/16	14 9/16	13 ½	54 2 ⅛	22 .866	6 .236	M10 ⅜	PL201 PL201	AS203 AS203-011	2,160	1,040
20 ¾	ASPL204 ASPL204-012	31.75 1 ¼	127 5	95 3 ¾	38 1 ½	13 ½	16 5/8	14 9/16	64 2 17/32	25 .984	7 .276	M10 ⅜	PL204 PL204	AS204 AS204-012	2,890	1,500
25 1 3/16 7/8 15/16 1	ASPL205 ASPL205-013 ASPL205-014 ASPL205-015 ASPL205-100	33.34 1 5/16	140 5 ½	105 4 1/8	38 1 ½	13 ½	16 5/8	15 19/32	68 2 11/16	27 1.063	7.5 .295	M10 ⅜	PL205 PL205 PL205 PL205	AS205 AS205-013 AS205-014 AS205-015 AS205-100	3,150	1,770
30 1 1/16 1 1/8 1 3/16 1 ¼	ASPL206 ASPL206-101 ASPL206-102 ASPL206-103 ASPL206-104	39.69 1 9/16	165 6 ½	121 4 ¾	48 1 7/8	17 21/32	20 25/32	17 21/32	80 3 5/32	29 1.142	8 .315	M14 ½	PL206 PL206 PL206 PL206	AS206 AS206-101 AS206-102 AS206-103 AS206-104	4,400	2,540
35 1 ¼ 1 5/16 1 3/8 1 7/16	ASPL207 ASPL207-104 ASPL207-105 ASPL207-106 ASPL207-107	46.04 1 13/16	167 6 5/16	127 5	48 1 7/8	17 21/32	20 25/32	18 23/32	91 3 19/32	34 1.339	8.5 .335	M14 ½	PL207 PL207 PL207 PL207	AS207 AS207-104 AS207-105 AS207-106 AS207-107	5,750	3,440

Note: ASPL201 - ASPL205 have a solid base

Units: Millimeters
INCHES

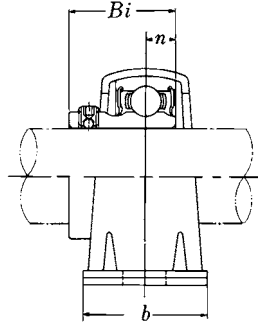
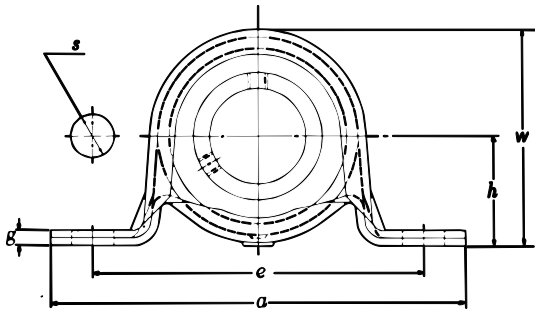

PILLOW BLOCKS - PRESSED STEEL HOUSING

Shaft Dia.	Complete Pillow Block Number	Nominal Dimensions									Bolt Size	Housing Number	Bearing Number	Basic Load Ratings (lbs)		Max. Radial Load (lbs)
		h	a	e	b	s	g	w	Bi	n				Dynamic C	Static C ₀	
12 1/2	ASPP201 ASPP201-008	22.2 7/8	86 3 3/8	68 2 11/16	25 3 1/32	9.5 3/8	3.2 .126	43.8 1 23/32	22 .866	6 .236	M8 5/16	PP203 PP203	AS201 AS201-008	2,160	1,040	440
15 9/16 5/8	ASPP202 ASPP202-009 ASPP202-010	22.2 7/8	86 3 3/8	68 2 11/16	25 3 1/32	9.5 3/8	3.2 .126	43.8 1 23/32	22 .866	6 .236	M8 5/16	PP203 PP203 PP203	AS202 AS202-009 AS202-010	2,160	1,040	440
17 11/16	ASPP203 ASPP203-011	22.2 7/8	86 3 3/8	68 2 11/16	25 3 1/32	9.5 3/8	3.2 .126	43.8 1 23/32	22 .866	6 .236	M8 5/16	PP203 PP203	AS203 AS203-011	2,160	1,040	440
20 3/4	ASPP204 ASPP204-012	25.4 1	98 3 27/32	76 3	32 1 1/4	9.5 3/8	3.2 .126	50.5 2	25 .984	7 .276	M8 5/16	PP204 PP204	AS204 AS204-012	2,890	1,500	550
25 13/16 7/8 15/16 1	ASPP205 ASPP205-013 ASPP205-014 ASPP205-015 ASPP205-100	28.6 1 1/8	108 4 1/4	86 3 3/8	32 1 1/4	11 7/16	4 .157	56.6 2 7/32	27 1.063	7.5 .295	M10 3/8	PP205 PP205 PP205 PP205 PP205	AS205 AS205-013 AS205-014 AS205-015 AS205-100	3,150	1,770	770
30 1 1/16 1 1/8 1 3/16 1 1/4	ASPP206 ASPP206-101 ASPP206-102 ASPP206-103 ASPP206-104	33.3 1 5/16	117 4 19/32	95 3 3/4	38 1 1/2	11 7/16	4 .157	66.3 2 5/8	29 1.142	8 .315	M10 3/8	PP206 PP206 PP206 PP206 PP206	AS206 AS206-101 AS206-102 AS206-103 AS206-104	4,400	2,540	880
35 1 1/4 1 5/16 1 3/8 1 7/16	ASPP207 ASPP207-104 ASPP207-105 ASPP207-106 ASPP207-107	39.7 1 9/16	129 5 3/32	106 4 3/16	42 1 21/32	11 7/16	4.6 .181	78 3 1/16	34 1.339	8.5 .335	M10 3/8	PP207 PP207 PP207 PP207 PP207	AS207 AS207-104 AS207-105 AS207-106 AS207-107	5,750	3,440	990

Axial load should be less than 1/3 of radial load.

NTN
SERIES
UELP2
ECCENTRIC
LOCKING
COLLAR
TYPE

Units: Millimeters
 INCHES

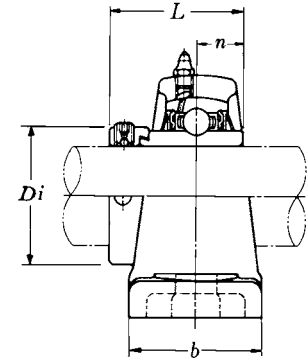
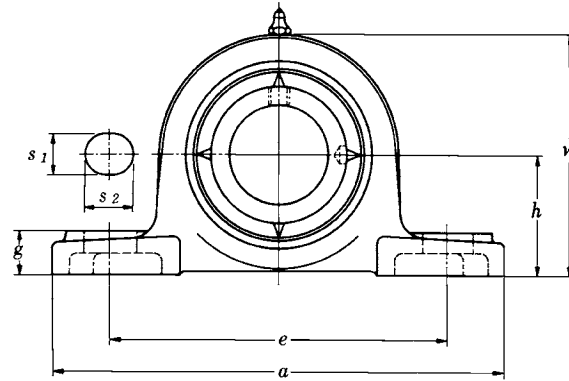

PILLOW BLOCKS - CAST HOUSING

Shaft Dia.	Complete Pillow Block Number	Nominal Dimensions											Bolt Size	Housing Number	Bearing Number	Basic Load Ratings (lbs)	
		h	a	e	b	s_1	s_2	g	w	Di	L	n				Dynamic C	Static C_o
20 3/4	UEL204D1 UEL204-012D1	33.3 1 5/16	127 5	95 3 3/4	38 1 1/2	13 1/2	16 5/8	14 9/16	65 2 9/16	33.3 1.31	43.7 1.720	17.1 .673	M10 3/8	P204D1 P204D1	UEL204D1 UEL204-012D1	2,890	1,500
25 1 3/16 7/8 1 1/16 1	UEL205D1 UEL205-013D1 UEL205-014D1 UEL205-015D1 UEL205-100D1	36.5 1 7/16	140 5 1/2	105 4 1/8	38 1 1/2	13 1/2	16 5/8	15 1 1/8	71 2 25/32	38.1 1.50	44.4 1.748	17.5 .689	M10 3/8	P205D1 P205D1 P205D1 P205D1 P205D1	UEL205D1 UEL205-013D1 UEL205-014D1 UEL205-015D1 UEL205-100D1	3,150	1,770
30 1 1/16 1 1/8 1 3/16 1 1/4	UEL206D1 UEL206-101D1 UEL206-102D1 UEL206-103D1 UEL206-104D1	42.9 1 11/16	165 6 1/2	121 4 3/4	48 1 7/8	17 21/32	20 25/32	17 21/32	83 3 3/32	44.5 1.75	48.4 1.906	18.3 .720	M14 1/2	P206D1 P206D1 P206D1 P206D1 P206D1	UEL206D1 UEL206-101D1 UEL206-102D1 UEL206-103D1 UEL206-104D1	4,400	2,540
35 1 1/4 1 5/16 1 3/8 1 7/16	UEL207D1 UEL207-104D1 UEL207-105D1 UEL207-106D1 UEL207-107D1	47.6 1 7/8	167 6 9/16	127 5	48 1 7/8	17 21/32	20 25/32	18 23/32	93 3 21/32	55.6 2.19	51.1 2.012	18.8 .740	M14 1/2	P207D1 P207D1 P207D1 P207D1 P207D1	UEL207D1 UEL207-104D1 UEL207-105D1 UEL207-106D1 UEL207-107D1	5,750	3,440
40 1 1/2 1 9/16	UEL208D1 UEL208-108D1 UEL208-109D1	49.2 1 15/16	184 7 1/4	137 5 13/32	54 2 1/8	17 21/32	20 25/32	18 23/32	98 3 27/32	60.2 2.37	56.3 2.217	21.4 .843	M14 1/2	P208D1 P208D1 P208D1	UEL208D1 UEL208-108D1 UEL208-109D1	6,550	4,000
45 1 5/8 1 11/16 1 3/4	UEL209D1 UEL209-110D1 UEL209-111D1 UEL209-112D1	54 2 1/8	190 7 15/32	146 5 3/4	54 2 1/8	17 21/32	20 25/32	20 25/32	106 4 3/16	63.5 2.50	56.3 2.217	21.4 .843	M14 1/2	P209D1 P209D1 P209D1 P209D1	UEL209D1 UEL209-110D1 UEL209-111D1 UEL209-112D1	7,350	4,590
50 1 13/16 1 7/8 1 15/16 2	UEL210D1 UEL210-113D1 UEL210-114D1 UEL210-115D1 UEL210-200D1	57.2 2 1/4	206 8 1/8	159 6 1/4	60 2 3/8	20 25/32	23 29/32	21 13/16	114 4 1/2	69.9 2.75	62.7 2.469	24.6 .969	M16 5/8	P210D1 P210D1 P210D1 P210D1 P210D1	UEL210D1 UEL210-113D1 UEL210-114D1 UEL210-115D1 UEL210-200D1	7,900	5,220
55 2 2 1/16 2 1/8 2 3/16	UEL211D1 UEL211-200D1 UEL211-201D1 UEL211-202D1 UEL211-203D1	63.5 2 1/2	219 8 5/8	171 6 23/32	60 2 3/8	20 25/32	23 29/32	23 29/32	126 4 31/32	76.2 3.00	71.4 2.811	27.8 1.094	M16 3/8	P211D1 P211D1 P211D1 P211D1 P211D1	UEL211D1 UEL211-200D1 UEL211-201D1 UEL211-202D1 UEL211-203D1	9,750	6,570
60 2 1/4 2 3/8 2 7/16	UEL212D1 UEL212-204D1 UEL212-206D1 UEL212-207D1	69.8 2 3/4	241 9 1/2	184 7 1/4	70 2 3/4	20 25/32	23 29/32	25 31/32	138 5 7/16	84.1 3.31	77.8 3.063	31 1.220	M16 5/8	P212D1 P212D1 P212D1 P212D1	UEL212D1 UEL212-204D1 UEL212-206D1 UEL212-207D1	11,800	8,100
65 2 1/2	UEL213D1 UEL213-208D1	76.2 3	265 10 7/16	203 8	70 2 3/4	25 31/32	28 1 1/32	27 1 1/16	151 5 15/16	97.0 3.82	85.7 3.374	34.15 1.344	M20 3/4	P213D1 P213D1	UEL213D1 UEL213-208D1	12,900	9,000
70 2 11/16 2 3/4	UEL214D1 UEL214-211D1 UEL214-212D1	79.4 3 3/8	266 10 15/32	210 8 9/32	72 2 27/32	25 31/32	28 1 3/32	27 1 1/16	157 6 3/16	97.0 3.82	85.7 3.374	34.15 1.344	M20 3/4	P214D1 P214D1 P214D1	UEL214D1 UEL214-211D1 UEL214-212D1	14,000	9,900
75 2 15/16 3	UEL215D1 UEL215-215D1 UEL215-300D1	82.6 3 1/4	275 10 13/16	217 8 17/32	74 2 29/32	25 31/32	28 1 3/32	28 1 3/32	163 6 13/32	97.0 3.82	92 3.622	37.3 1.469	M20 3/4	P215D1 P215D1 P215D1	UEL215D1 UEL215-215D1 UEL215-300D1	14,900	11,130

Units: Millimeters
INCHES

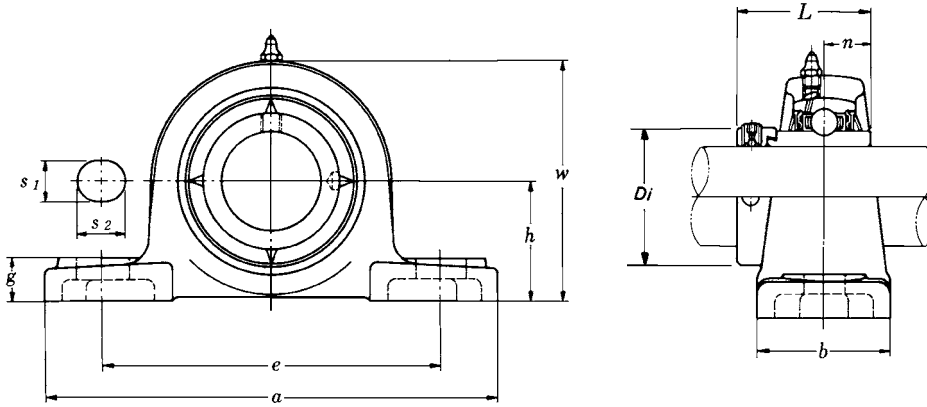

PILLOW BLOCKS - CAST HOUSING (LOW CENTER HEIGHT)

Shaft Dia.	Complete Pillow Block Number	Nominal Dimensions											Bolt Size	Housing Number	Bearing Number	Basic Load Ratings (lbs)	
		h	a	e	b	s ₁	s ₂	g	w	Di	L	n				Dynamic C	Static C ₀
20 3/4	UELPL204D1	31.75	127	95	38	13	16	14	64	33.3	43.7	17.1	M10 3/8	PL204D1 PL204D1	UEL204D1 UEL204-012D1	2,890	1,500
	UELPL204-012D1	1 1/4	5	3 3/4	1 1/2	1/2	5/8	9/16	2 17/32	1.31	1.920	.673					
25 1 3/16 7/8 1 1/16 1	UELPL205D1	33.34	140	105	38	13	16	15	68	38.1	44.4	17.5	M10 3/8	PL205D1 PL205D1 PL205D1 PL205D1	UEL205D1 UEL205-013D1 UEL205-014D1 UEL205-015D1 UEL205-100D1	3,150	1,770
	UELPL205-013D1	1 3/16	5 1/2	4 1/8	1 1/2	1/2	5/8	19/32	2 1 1/16	1.50	1.748	.689					
	UELPL205-014D1																
	UELPL205-015D1																
30 1 1/16 1 1/8 1 3/16 1 1/4	UELPL206D1	39.69	165	121	48	17	20	17	80	44.5	48.4	18.3	M14 1/2	PL206D1 PL206D1 PL206D1 PL206D1	UEL206D1 UEL206-101D1 UEL206-102D1 UEL206-103D1 UEL206-104D1	4,400	2,540
	UELPL206-101D1	1 3/16	6 1/2	4 3/4	1 7/8	2 1/32	25/32	2 1/32	3 5/32	1.75	1.906	.720					
	UELPL206-102D1																
	UELPL206-103D1																
35 1 1/4 1 5/16 1 3/8 1 7/16	UELPL207D1	46.04	167	127	48	17	20	18	91	55.6	51.1	18.8	M14 1/2	PL207D1 PL207D1 PL207D1 PL207D1	UEL207D1 UEL207-104D1 UEL207-105D1 UEL207-106D1 UEL207-107D1	5,750	3,440
	UELPL207-104D1	1 13/16	6 9/16	5	1 7/8	2 1/32	25/32	23/32	3 19/32	2.19	2.012	.740					
	UELPL207-105D1																
	UELPL207-106D1																
45 1 5/8 1 11/16 1 3/4	UELPL209D1	52.39	190	146	54	17	20	20	104	63.5	56.3	21.4	M14 1/2	PL209D1 PL209D1 PL209D1	UEL209D1 UEL209-110D1 UEL209-111D1 UEL209-112D1	7,350	4,590
	UELPL209-110D1	2 1/16	7 15/32	5 3/4	2 1/8	2 1/32	25/32	25/32	4 3/32	2.50	2.217	.843					
	UELPL209-111D1																
50 1 13/16 1 7/8 1 15/16 2	UELPL210D1	55.56	206	159	60	20	23	21	112	69.9	62.7	24.6	M16 3/8	PL210D1 PL210D1 PL210D1 PL210D1	UEL210D1 UEL210-113D1 UEL210-114D1 UEL210-115D1 UEL210-200D1	7,900	5,220
	UELPL210-113D1	2 3/16	8 1/8	6 1/4	2 3/8	25/32	29/32	1 13/16	4 13/32	2.75	2.469	.969					
	UELPL210-114D1																
	UELPL210-115D1																

Note: These numbers indicate relubricatable type. If maintenance free type is needed, please order without suffix D1
 UELPL204 and UELPL205 have solid bases.
 UELPL208 has the same dimensions as UELP208 shown on page 164

NTN
SERIES
UEL3
ECCENTRIC
LOCKING
COLLAR
TYPE

Units: Millimeters
 INCHES

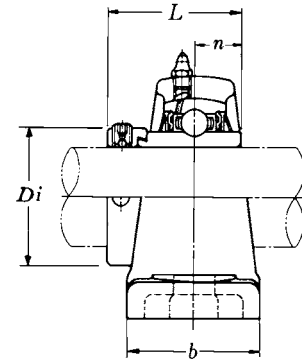
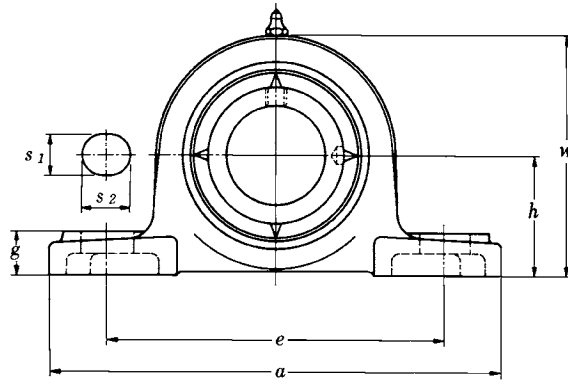

PILLOW BLOCKS - CAST HOUSING

Shaft Dia.	Complete Pillow Block Number	Nominal Dimensions											Bolt Size	Housing Number	Bearing Number	Basic Load Ratings (lbs)	
		h	a	e	b	s ₁	s ₂	g	w	Di	L	n				Dynamic C	Static C ₀
25 7/8 15/16 1	UEL305D1 UEL305-014D1 UEL305-015D1 UEL305-100D1	45 1 49/64	175 6 7/8	132 5 3/16	45 1 25/32	17 21/32	20 25/32	15 19/32	85 3 11/32	42.8 1.69	46.8 1.843	16.7 .657	M14 1/2	P305D1 P305D1 P305D1 P305D1	UEL305D1 UEL305-014D1 UEL305-015D1 UEL305-100D1	4,750	2,460
30 1 1/8 1 3/16	UEL306D1 UEL306-102D1 UEL306-103D1	50 1 31/32	180 7 3/32	140 5 1/2	50 1 31/32	17 21/32	20 25/32	18 23/32	95 3 3/4	50 1.97	50 1.969	17.5 .689	M14 1/2	P306D1 P306D1 P306D1	UEL306D1 UEL306-102D1 UEL306-103D1	6,000	3,400
35 1 1/4 1 5/16 1 3/8 1 7/16	UEL307D1 UEL307-104D1 UEL307-105D1 UEL307-106D1 UEL307-107D1	56 2 13/64	210 8 9/32	160 6 5/16	56 2 7/32	17 21/32	25 31/32	20 29/32	106 4 3/16	55 2.17	51.6 2.031	18.3 .720	M14 1/2	P307D1 P307D1 P307D1 P307D1 P307D1	UEL307D1 UEL307-104D1 UEL307-105D1 UEL307-106D1 UEL307-107D1	7,500	4,300
40 1 1/2	UEL308D1 UEL308-108D1	60 2 23/64	220 8 21/32	170 6 11/16	60 2 3/8	17 21/32	27 1 1/16	22 7/8	116 4 9/16	63.5 2.50	57.1 2.248	19.8 .780	M14 1/2	P308D1 P308D1	UEL308D1 UEL308-108D1	9,150	5,400
45 1 5/8 1 11/16 1 3/4	UEL309D1 UEL309-110D1 UEL309-111D1 UEL309-112D1	67 2 41/64	245 9 21/32	190 7 15/32	67 2 5/8	20 25/32	30 1 3/16	24 15/16	129 5 3/32	70 2.76	58.7 2.311	19.8 .780	M16 5/8	P309D1 P309D1 P309D1 P309D1	UEL309D1 UEL309-110D1 UEL309-111D1 UEL309-112D1	11,900	7,200
50 1 7/8 1 15/16	UEL310D1 UEL310-114D1 UEL310-115D1	75 2 61/64	275 10 13/16	212 8 11/32	75 2 15/16	20 25/32	35 1 3/8	27 1 1/16	143 5 5/8	76.2 3.00	66.6 2.622	24.6 .969	M16 5/8	P310D1 P310D1 P310D1	UEL310D1 UEL310-114D1 UEL310-115D1	13,900	8,600
55 2 2 1/8 2 3/16	UEL311D1 UEL311-200D1 UEL311-202D1 UEL311-203D1	80 3 3/32	310 12 7/32	236 9 9/32	80 3 3/32	20 25/32	38 1 1/2	30 1 3/16	154 6 1/16	83 3.27	73 2.874	27.8 1.094	M16 5/8	P311D1 P311D1 P311D1 P311D1	UEL311D1 UEL311-200D1 UEL311-202D1 UEL311-203D1	16,100	10,100
60 2 1/4 2 3/8 2 7/16	UEL312D1 UEL312-204D1 UEL312-206D1 UEL312-207D1	85 3 11/32	330 13	250 9 27/32	85 3 11/32	25 31/32	38 1 1/2	32 1 1/4	165 6 1/2	89 3.50	79.4 3.126	30.95 1.219	M20 3/4	P312D1 P312D1 P312D1 P312D1	UEL312D1 UEL312-204D1 UEL312-206D1 UEL312-207D1	18,400	11,700
65 2 1/2	UEL313D1 UEL313-208D1	90 3 35/64	340 13 3/8	260 10 1/4	90 3 17/32	25 31/32	38 1 1/2	33 1 9/16	176 6 15/16	97 3.82	85.7 3.374	32.55 1.281	M20 3/4	P313D1 P313D1	UEL313D1 UEL313-208D1	20,800	13,400
70 2 11/16 2 3/4	UEL314D1 UEL314-211D1 UEL314-212D1	95 3 47/64	360 14 3/16	280 11 1/32	90 3 17/32	27 1 1/16	40 1 9/16	35 1 3/8	187 7 3/8	102 4.00	92.1 3.626	34.15 1.344	M22 7/8	P314D1 P314D1 P314D1	UEL314D1 UEL314-211D1 UEL314-212D1	23,400	15,300
75 2 15/16 3	UEL315D1 UEL315-215D1 UEL315-300D1	100 3 15/16	380 14 31/32	290 11 13/32	100 3 15/16	27 1 1/16	40 1 9/16	35 1 3/8	198 7 25/32	113 4.45	100 3.937	37.3 1.469	M22 7/8	P315D1 P315D1 P315D1	UEL315D1 UEL315-215D1 UEL315-300D1	25,500	17,400
80 3 1/8 3 3/16	UEL316D1 UEL316-302D1 UEL316-303D1	106 4 11/64	400 15 3/4	300 11 13/16	110 4 11/32	27 1 1/16	40 1 9/16	40 1 9/16	210 8 9/32	119 4.69	106.4 4.189	40.5 1.594	M22 7/8	P316D1 P316D1 P316D1	UEL316D1 UEL316-302D1 UEL316-303D1	27,600	19,500
85 3 1/4	UEL317D1 UEL317-304D1	112 4 13/32	420 16 17/32	320 12 19/32	110 4 11/32	33 1 5/16	45 1 25/32	40 1 9/16	220 8 21/32	127 5.00	109.5 4.311	42.05 1.656	M27 1	P317D1 P317D1	UEL317D1 UEL317-304D1	29,800	21,800
90 3 7/16 3 1/2	UEL318D1 UEL318-307D1 UEL318-308D1	118 4 41/64	430 16 15/16	330 13	110 4 11/32	33 1 5/16	45 1 25/32	45 1 25/32	235 9 1/4	133 5.24	115.9 4.563	43.65 1.719	M27 1	P318D1 P318D1 P318D1	UEL318D1 UEL318-307D1 UEL318-308D1	32,000	24,100
95 3 3/4	UEL319D1 UEL319-312D1	125 4 59/64	470 18 1/2	360 14 3/16	120 4 23/32	36 1 13/32	50 1 31/32	45 1 25/32	250 9 27/32	140 5.50	122.3 4.815	38.9 1.531	M30 1 1/8	P319D1 P319D1	UEL319D1 UEL319-312D1	34,500	26,600
100 3 15/16 4	UEL320D1 UEL320-315D1 UEL320-400D1	140 5 39/64	490 19 9/32	380 14 31/32	120 4 23/32	36 1 13/32	50 1 31/32	50 1 31/32	275 10 13/16	146 5.75	128.6 5.063	50 1.969	M30 1 1/8	P320D1 P320D1 P320D1	UEL320D1 UEL320-315D1 UEL320-400D1	39,000	31,500
105	UEL321D1	140	490	380	120	36	50	50	280	157	139.7	48.4	M30	P321D1	UEL321D1	41,500	34,500
110	UEL322D1	150	520	400	140	40	55	55	300	168	141.3	49.2	M33	P322D1	UEL322D1	46,000	40,500

Units: Millimeters
INCHES

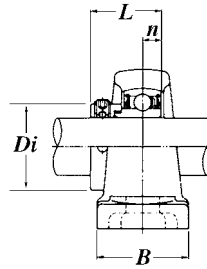
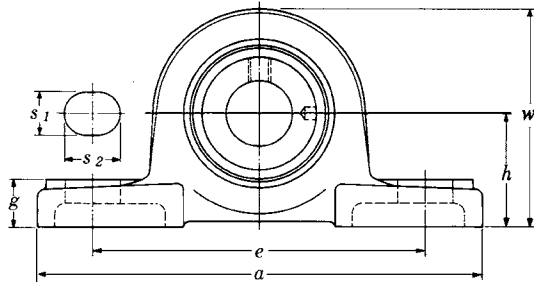

PILLOW BLOCKS - CAST HOUSING (LOW CENTER HEIGHT)

Shaft Dia.	Complete Pillow Block Number	Nominal Dimensions											Bolt Size	Housing Number	Bearing Number	Basic Load Ratings (lbs)	
		<i>h</i>	<i>a</i>	<i>e</i>	<i>b</i>	<i>s</i> ₁	<i>s</i> ₂	<i>g</i>	<i>w</i>	<i>Di</i>	<i>L</i>	<i>n</i>				Dynamic <i>C</i>	Static <i>C</i> ₀
12 1/2	JELPL201 JELPL201-008	26.99 1 1/16	121 4 3/4	89 3 1/2	35 1 3/8	11 7/16	14 9/16	13 1/2	54 2 1/8	29 1.14	28.6 1.126	6.5 .256	M10 3/8	PL201 PL201	JEL201 JEL201-008	2,160	1,030
15 9/16 5/8	JELPL202 JELPL202-009 JELPL202-010	26.99 1 1/16	121 4 3/4	89 3 1/2	35 1 3/8	11 7/16	14 9/16	13 1/2	54 2 1/8	29 1.14	28.6 1.126	6.5 .256	M10 3/8	PL201 PL201 PL201	JEL202 JEL202-009 JEL202-010	2,160	1,030
17 1 1/16	JELPL203 JELPL203-011	26.99 1 1/16	121 4 3/4	89 3 1/2	35 1 3/8	11 7/16	14 9/16	13 1/2	54 2 1/8	29 1.14	28.6 1.126	6.5 .256	M10 3/8	PL201 PL201	JEL203 JEL203-011	2,160	1,030
20 3/4	JELPL204 JELPL204-012	31.75 1 1/4	127 5	95 3 3/4	38 1 1/2	13 1/2	16 5/8	14 9/16	64 2 17/32	33.3 1.31	31 1.220	7.5 .295	M10 3/8	PL204 PL204	JEL204 JEL204-012	2,890	1,500
25 1 3/16 7/8 1 5/16 1	JELPL205 JELPL205-013 JELPL205-014 JELPL205-015 JELPL205-100	33.34 1 5/16	140 5 1/2	105 4 1/8	38 1 1/2	13 1/2	16 5/8	15 19/32	68 2 1 1/16	38.1 1.50	31 1.220	7.5 .295	M10 3/8	PL205 PL205 PL205 PL205 PL205	JEL205 JEL205-013 JEL205-014 JEL205-015 JEL205-100	3,150	1,770
30 1 1/16 1 1/8 1 3/16 1 1/4	JELPL206 JELPL206-101 JELPL206-102 JELPL206-103 JELPL206-104	39.69 1 9/16	165 6 1/2	121 4 3/4	48 1 7/8	17 21/32	20 25/32	17 21/32	80 3 5/32	44.5 1.75	35.7 1.406	9 .354	M14 1/2	PL206 PL206 PL206 PL206 PL206	JEL206 JEL206-101 JEL206-102 JEL206-103 JEL206-104	4,400	2,540
35 1 1/4 1 5/16 1 3/8 1 7/16	JELPL207 JELPL207-104 JELPL207-105 JELPL207-106 JELPL207-107	46.04 1 13/16	167 6 9/16	127 5	48 1 7/8	17 21/32	20 25/32	18 23/32	91 3 19/32	55.6 2.19	38.9 1.531	9.5 .374	M14 1/2	PL207 PL207 PL207 PL207 PL207	JEL207 JEL207-104 JEL207-105 JEL207-106 JEL207-107	5,750	3,450

NTN
SERIES
AELP2
ECCENTRIC
LOCKING
COLLAR
TYPE

Units: **Millimeters**
INCHES

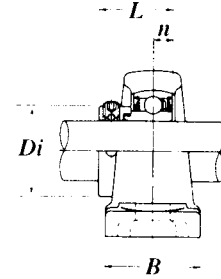
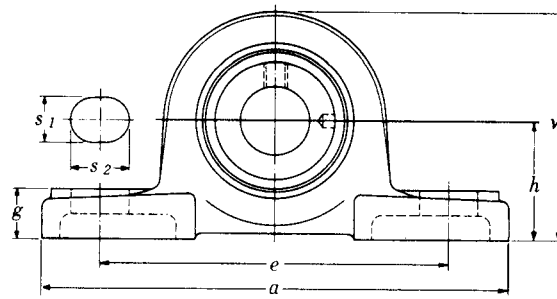

PILLOW BLOCKS - CAST HOUSING

Shaft Diameter	Complete Pillow Block Number	Nominal Dimensions											Bolt Size	Housing Number	Bearing Number	Basic Load Ratings (lbs)	
		h	a	e	b	s_1	s_2	g	w	Di	L	n				<i>dynamic</i> C	<i>static</i> C_0
20 3/4	AELP204D1 AELP204-012D1	33.34 1 5/16	127 5	95 3 3/4	38 1 1/2	13 1/2	16 5/8	14 9/16	65.09 2 7/16	33.3 1.31	31 1.220	7.5 .295	M10 3/8	P204D1 P204D1	AEL204D1 AEL204-012D1	2,890	1,500
25 1 3/16 7/8 1 1/4	AELP205D1 AELP205-013D1 AELP205-014D1 AELP205-015D1 AELP205-100D1	36.51 1 7/16	140 5 1/2	105 4 1/8	38 1 1/2	13 1/2	16 5/8	15 19/32	70.64 2 25/32	38.1 1.50	31 1.220	7.5 .295	M10 3/8	P205D1 P205D1 P205D1 P205D1 P205D1	AEL205D1 AEL205-013D1 AEL205-014D1 AEL205-015D1 AEL205-100D1	3,150	1,770
30 1 1/16 1 1/8 1 3/16 1 1/4	AELP206D1 AELP206-101D1 AELP206-102D1 AELP206-103D1 AELP206-104D1	42.86 1 11/16	165 6 1/2	121 4 3/4	48 1 7/8	17 2 1/32	20 25/32	17 2 1/32	83.34 3 9/32	44.50 1.75	35.7 1.406	9.0 .354	M14 1/2	P206D1 P206D1 P206D1 P206D1 P206D1	AEL206D1 AEL206-101D1 AEL206-102D1 AEL206-103D1 AEL206-104D1	4,400	2,540
35 1 1/4 1 5/16 1 3/8 1 7/16	AELP207D1 AELP207-104D1 AELP207-105D1 AELP207-106D1 AELP207-107D1	47.63 1 7/8	167 6 9/16	127 5	48 1 7/8	17 2 1/32	20 25/32	18 2 1/32	92.87 3 21/32	55.6 2.19	38.9 1.531	9.5 .374	M14 1/2	P207D1 P207D1 P207D1 P207D1 P207D1	AEL207D1 AEL207-104D1 AEL207-105D1 AEL207-106D1 AEL207-107D1	5,750	3,440
40 1 1/2 1 3/16	AELP208D1 AELP208-108D1 AELP208-109D1	49.2 1 15/16	184 7 1/4	137 5 3/8	54 2 1/8	17 2 1/32	20 25/32	18 2 1/32	98 3 27/32	52 2.37	49.2 1.719	19 .433	M14 1/2	P208D1 P208D1 P208D1	AEL208D1 AEL208-108D1 AEL208-109D1	6,550	4,000
45 1 5/8 1 11/16 1 3/4	AELP209D1 AELP209-110D1 AELP209-111D1 AELP209-112D1	54 2 1/8	190 7 15/32	146 5 3/4	54 2 1/8	17 2 1/32	20 25/32	20 2 1/32	106 4 3/16	60 2 3/8	49.2 1.937	19 .748	M14 1/2	P209D1 P209D1 P209D1 P209D1	AEL209D1 AEL209-110D1 AEL209-111D1 AEL209-112D1	7,350	4,590
50 1 13/16 1 7/8 1 15/16	AELP210D1 AELP210-113D1 AELP210-114D1 AELP210-115D1	57.2 2 1/4	206 8 1/8	159 6 1/4	60 2 3/8	20 25/32	23 29/32	21 1 3/16	114 4 1/2	65 2 9/16	51.6 2.031	19 .749	M16 3/8	P210D1 P210D1 P210D1 P210D1	AEL210D1 AEL210-113D1 AEL210-114D1 AEL210-115D1	7,900	5,220

Units: Millimeters
INCHES

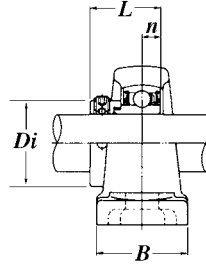
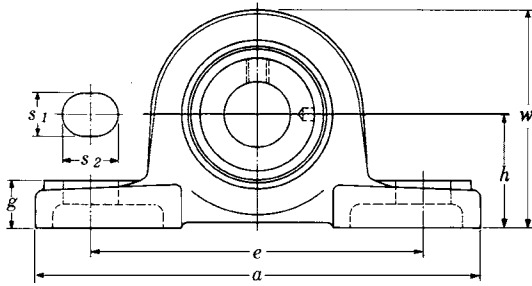

PILLOW BLOCKS - CAST HOUSING (LOW CENTER HEIGHT)

Shaft Dia.	Complete Pillow Block Number	Nominal Dimensions											Bolt Size	Housing Number	Bearing Number	Basic Load Ratings (lbs)	
		h	a	e	b	s ₁	s ₂	g	w	Di	L	n				Dynamic C	Static C ₀
12 1/2	AELPL201 AELPL201-008	26.99 1 1/16	121 4 3/4	89 3 1/2	35 1 3/8	11 7/16	14 9/16	13 1/2	54 2 1/8	29 1.14	28.6 1.126	6.5 .256	M10 3/8	PL201 PL201	AEL201 AEL201-008	2,160	1,040
15 9/16 5/8	AELPL202 AELPL202-009 AELPL202-010	26.99 1 1/16	121 4 3/4	89 3 1/2	35 1 3/8	11 7/16	14 9/16	13 1/2	54 2 1/8	29 1.14	28.6 1.126	6.5 .256	M10 3/8	PL201 PL201 PL201	AEL202 AEL202-009 AEL202-010	2,160	1,040
17 11/16	AELPL203 AELPL203-011	26.99 1 1/16	121 4 3/4	89 3 1/2	35 1 3/8	11 7/16	14 9/16	13 1/2	54 2 1/8	29 1.14	28.6 1.126	6.5 .256	M10 3/8	PL201 PL201	AEL203 AEL203-011	2,160	1,040
20 3/4	AELPL204 AELPL204-012	31.75 1 1/4	127 5	95 3 3/4	38 1 1/2	13 1/2	16 5/8	14 9/16	64 2 17/32	33.3 1.31	31 1.220	7.5 .295	M10 3/8	PL204 PL204	AEL204 AEL204-012	2,890	1,500
25 13/16 7/8 15/16 1	AELPL205 AELPL205-013 AELPL205-014 AELPL205-015 AELPL205-100	33.34 1 5/16	140 5 1/2	105 4 1/8	38 1 1/2	13 1/2	16 5/8	15 19/32	68 2 11/16	38.1 1.50	31 1.220	7.5 .295	M10 3/8	PL205 PL205 PL205 PL205 PL205	AEL205 AEL205-013 AEL205-014 AEL205-015 AEL205-100	3,150	1,770
30 1 1/16 1 1/8 1 3/16 1 1/4	AELPL206 AELPL206-101 AELPL206-102 AELPL206-103 AELPL206-104	39.69 1 9/16	165 6 1/2	121 4 3/4	48 1 7/8	17 21/32	20 25/32	17 21/32	80 3 5/32	44.5 1.75	35.7 1.406	9 .354	M14 1/2	PL206 PL206 PL206 PL206 PL206	AEL206 AEL206-101 AEL206-102 AEL206-103 AEL206-104	4,400	2,540
35 1 1/4 1 5/16 1 3/8 1 7/16	AELPL207 AELPL207-104 AELPL207-105 AELPL207-106 AELPL207-107	46.04 1 13/16	167 6 9/16	127 5	48 1 7/8	17 21/32	20 25/32	18 23/32	91 3 19/32	55.6 2.19	38.9 1.531	9.5 .374	M14 1/2	PL207 PL207 PL207 PL207 PL207	AEL207 AEL207-104 AEL207-105 AEL207-106 AEL207-107	5,750	3,440

Note: AELPL201 - AELPL205 have a solid base

NTN
SERIES
AELPP2
ECCENTRIC
LOCKING
COLLAR
TYPE

Units: Millimeters
 INCHES

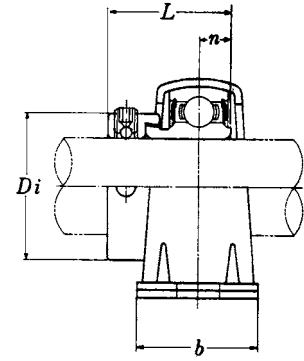
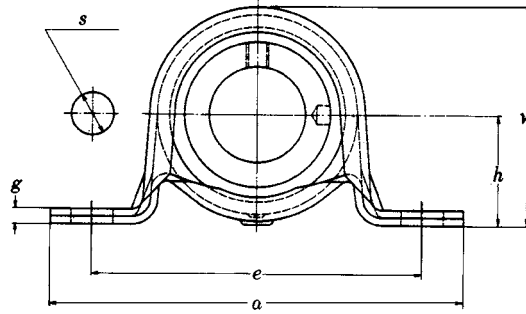

PILLOW BLOCKS - PRESSED STEEL HOUSING

Shaft Dia.	Complete Pillow Block Number	Nominal Dimensions									Bolt Size	Housing Number	Bearing Number	Basic Load Ratings (lbs)		Max. Radial Load (lbs)
		<i>h</i>	<i>a</i>	<i>e</i>	<i>b</i>	<i>s</i>	<i>g</i>	<i>w</i>	<i>L</i>	<i>n</i>				Dynamic C	Static C ₀	
12 ½	AELPP201 AELPP201-008	22.2 7/8	86 3 3/8	68 2 11/16	25 3 1/32	9.5 3/8	3.2 .126	43.8 1 23/32	28.6 1.126	6.5 .256	M8 5/16	PP203 PP203	AEL201 AEL201-008	2,160	1,040	440
15 9/16 5/8	AELPP202 AELPP202-009 AELPP202-010	22.2 7/8	86 3 3/8	68 2 11/16	25 3 1/32	9.5 3/8	3.2 .126	43.8 1 23/32	28.6 1.126	6.5 .256	M8 5/16	PP203 PP203 PP203	AEL202 AEL202-009 AEL202-010	2,160	1,040	440
17 1 1/16	AELPP203 AELPP203-011	22.2 7/8	86 3 3/8	68 2 11/16	25 3 1/32	9.5 3/8	3.2 .126	43.8 1 23/32	28.6 1.126	6.5 .256	M8 5/16	PP203 PP203	AEL203 AEL203-011	2,160	1,040	440
20 ¾	AELPP204 AELPP204-012	25.4 1	98 3 27/32	76 3	32 1 1/4	9.5 3/8	3.2 .126	50.5 2	31 1.220	7.5 .295	M8 5/16	PP204 PP204	AEL204 AEL204-012	2,890	1,500	550
25 1 3/16 7/8 15/16 1	AELPP205 AELPP205-013 AELPP205-014 AELPP205-015 AELPP205-100	28.6 1 1/8	108 4 1/4	86 3 3/8	32 1 1/4	11 7/16	4 .157	56.6 2 7/32	31 1.220	7.5 .295	M10 3/8	PP205 PP205 PP205 PP205 PP205	AEL205 AEL205-013 AEL205-014 AEL205-015 AEL205-100	3,150	1,770	770
30 1 1/16 1 1/8 1 3/16 1 1/4	AELPP206 AELPP206-101 AELPP206-102 AELPP206-103 AELPP206-104	33.3 1 5/16	117 4 19/32	95 3 3/4	38 1 1/2	11 7/16	4 .157	66.3 2 5/8	35.7 1.406	9 .354	M10 3/8	PP206 PP206 PP206 PP206 PP206	AEL206 AEL206-101 AEL206-102 AEL206-103 AEL206-104	4,400	2,540	880
35 1 1/4 1 5/16 1 3/8 1 7/16	AELPP207 AELPP207-104 AELPP207-105 AELPP207-106 AELPP207-107	39.7 1 9/16	129 5 3/32	106 4 3/16	42 1 21/32	11 7/16	4.6 .181	78 3 1/16	38.9 1.531	9.5 .374	M10 3/8	PP207 PP207 PP207 PP207 PP207	AEL207 AEL207-104 AEL207-105 AEL207-106 AEL207-107	5,750	3,440	990

Axial load should be less than 1/3 of radial load.

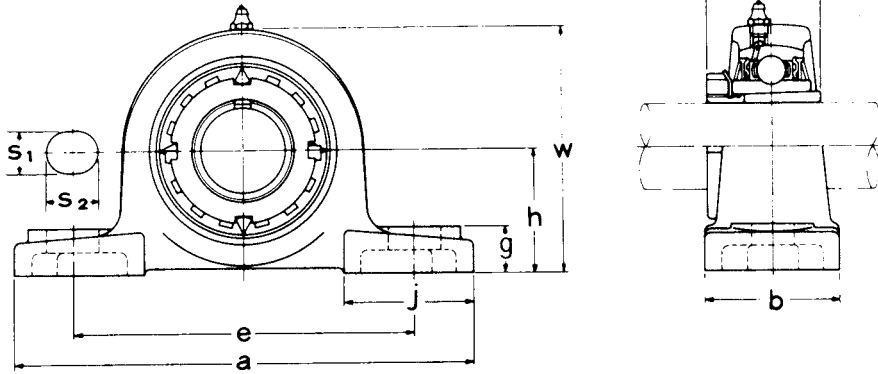
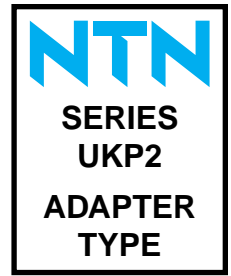

PILLOW BLOCKS - CAST HOUSING

Shaft Diameter	Unit Number	Nominal Dimensions										Bolt Size	Housing Number	Bearing Number	Basic Load Ratings (lbs)	
		h	a	e	b	s ₁	s ₂	g	w	L	j				dynamic C	static Co
20 ¾	UKP205D1 ; H 2305X UKP205D1 ; HE2305	36.5 1 7/16	140 5 ½	105 4 ½	38 1 ½	13 ½	16 5/8	15 19/32	71 2 25/32	35 1.378	42 1 21/32	M10 3/8	P205D1	UK205D1 ; H 2305X UK205D1 ; HE2305	3,150	1,770
25 7/8	UKP206D1 ; H 2306X UKP206D1 ; HS2306 UKP206D1 ; HE2306X	42.9 1 11/16	165 6 ½	121 4 ¾	48 1 7/8	17 2 1/32	20 25/32	17 2 1/32	83 3 3/32	38 1.496	54 2 1/8	M14 ½	P206D1	UK206D1 ; H 2306X UK206D1 ; HS2306 UK206D1 ; HE2306X	4,400	2,540
30 1 1/8	UKP207D1 ; H 2307X UKP207D1 ; HS2307	47.6 1 7/8	167 6 9/16	127 5	48 1 7/8	17 2 1/32	20 25/32	18 23/32	93 3 21/32	43 1.693	54 2 1/8	M14 ½	P207D1	UK207D1 ; H 2307X UK207D1 ; HS2307	5,750	3,450
35 1 ¼	UKP208D1 ; H 2308X UKP208D1 ; HE2308 UKP208D1 ; HS2308X	49.2 1 15/16	184 7 ¼	137 5 13/32	54 2 1/8	17 2 1/32	20 25/32	18 25/32	98 3 27/32	46 1.811	52 2 1/16	M14 ½	P207D1	UK208D1 ; H 2308X UK208D1 ; HE2308 UK208D1 ; HS2308X	6,550	4,000
40 1 7/16	UKP209D1 ; H 2309X UKP209D1 ; HA2309 UKP209D1 ; HE2309X UKP209D1 ; HS2309X	54 2 1/8	190 7 15/32	146 5 ¾	54 2 1/8	17 2 1/32	20 25/32	20 25/32	106 4 1/16	50 1.969	60 2 3/8	M14 ½	P208D1	UK209D1 ; H 2309X UK209D1 ; HA2309 UK209D1 ; HE2309X UK209D1 ; HS2309X	7,350	4,600
45 1 5/8	UKP210D1 ; H 2310X UKP210D1 ; HS2310 UKP210D1 ; HA2310 UKP210D1 ; HE2310X	57.2 2 ¼	206 8 1/8	159 6 ¼	60 2 3/8	20 25/32	23 29/32	21 13/16	114 4 ½	55 2.165	65 1 9/16	M16 5/8	P210D1	UK210D1 ; H 2310X UK210D1 ; HS2310 UK210D1 ; HA2310 UK210D1 ; HE2310X	7,900	5,200
50 1 7/8	UKP211D1 ; H 2311X UKP211D1 ; HS2311 UKP211D1 ; HA2311 UKP211D1 ; HE2311XY	63.5 2 ½	219 8 5/8	171 6 23/32	60 2 3/8	20 25/32	23 29/32	23 29/32	126 4 32/32	59 2.323	65 2 9/16	M16 5/8	P211D1	UK211D1 ; H 2311X UK211D1 ; HS2311 UK211D1 ; HA2311 UK211D1 ; HE2311XY	9,750	6,550
55 2 1/8	UKP212D1 ; H 2312X UKP212D1 ; HS2312	69.8 2 ¾	241 9 ½	184 7 ¼	70 2 ¾	20 25/32	23 29/32	25 31/32	138 5 7/16	62 2.441	70 2 ¾	M16 5/8	P212D1	UK212D1 ; H 2312X UK212D1 ; HS2312	11,800	8,150
60 2 3/16	UKP213D1 ; H 2313X UKP213D1 ; HA2313 UKP213D1 ; HE2313 UKP213D1 ; HS2313	76.2 3	265 10 7/16	203 8	70 2 ¾	25 3 1/32	28 1 3/32	27 1 1/16	151 5 15/16	65 2.559	77 3 1/32	M20 ¾	P213D1	UK213D1 ; H 2313X UK213D1 ; HA2313 UK213D1 ; HE2313 UK213D1 ; HS2313	12,900	9,000
65 2 7/16	UKP215D1 ; H 2315X UKP215D1 ; HA2315 UKP215D1 ; HE2315	82.6 3 ¼	275 10 13/16	217 8 17/32	74 2 29/32	25 3 1/32	28 1 3/32	27 1 3/32	151 6 13/32	65 2.874	77 3 5/32	M20 ¾	P215D1	UK215D1 ; H 2315X UK215D1 ; HA2315 UK215D1 ; HE2315	14,900	11,100
70 2 11/16	UKP216D1 ; H2316X UKP216D1 ; HA2316 UKP216D1 ; HE2316	88.9 3 ½	292 11 ½	232 9 1/8	78 3 1/16	25 3 1/32	28 1 3/32	30 1 3/16	175 6 7/8	78 3.071	85 3 11/32	M22 7/8	P216D1	UK216D1 ; H2316X UK216D1 ; HA2316 UK216D1 ; HE2316	16,300	11,900
75 2 15/16	UKP217D1 ; H 2317X UKP217D1 ; HA2317 UKP217D1 ; HE2317	95.2 3 ¾	310 12 7/32	247 9 23/32	83 3 9/32	25 3 1/32	28 1 3/32	32 1 1/4	187 7 3/8	82 3.228	85 3 11/32	M22 7/8	P217D1	UK217D1 ; H 2317X UK217D1 ; HA2317 UK217D1 ; HE2317	18,700	14,300
80 3 1/16	UKP218D1 ; H 2318X UKP218D1 ; HA2318	101.6 4	327 12 7/8	262 10 5/16	88 3 15/32	27 1 1/16	30 1 3/16	33 1 5/16	200 7 7/8	86 3.386	90 3 17/32	M22 7/8	P218D1	UK218D1 ; H 2318X UK218D1 ; HA2318	21,600	16,100

These numbers indicate re-lubricate type. If maintenance free type is needed, please order without suffix "D1".

Adapter number with suffix "X" means a narrow slot type adapter sleeve. In this case the lock washer with the straight inner prong should be used.

For HE2311XY, screw thread pitch different from the standard is applied, because of the thin thread section of sleeve. To distinguish it, a suffix "Y" is added.

Note: Please consult NTN Engineering for grease fitting details.



Bearing Series

UCP2 SERIES

UCP201D1

1.5

Complete Pillow Block Number

Weight (lbs)

GREENLINE PILLOW BLOCKS

LBS.

UCP2 SERIES	UCPL210-113D1	5.7	UCPX09-113D1	7.3	ASPP207	1.3
UCP201D1	UCPL210-114D1	5.7	UCPX10D1	9.5	ASPP207-104	1.3
UCP201-008D1	UCPL210-115D1	5.7	UCPX10-114D1	9.5	ASPP207-105	1.3
UCP202D1	UCPL210-200D1	5.7	UCPX10-115D1	9.5	ASPP207-106	1.3
UCP202-009D1	UCP3 SERIES		UCPX10-200D1	9.5	ASPP207-107	1.3
UCP202-010D1	UCP305D1	3.3	UCPX11D1	13.0	UELP2 SERIES	
UCP203D1	UCP305-014D1	3.3	UCPX11-202D1	13.0	UELPL204D1	1.5
UCP203-011D1	UCP305-015D1	3.3	UCPX11-203D1	13.0	UELPL204-012D1	1.5
UCP204D1	UCP305-100D1	3.3	UCPX11-204D1	13.0	UELPL205D1	2.0
UCP204-012D1	UCP306D1	4.0	UCPX11-205D1	13.0	UELPL205-013D1	2.0
UCP205D1	UCP306-102D1	4.0	UCPX12D1	16.0	UELPL205-014D1	2.0
UCP205-013D1	UCP306-103D1	4.0	UCPX12-206D1	16.0	UELPL205-015D1	2.0
UCP205-014D1	UCP307D1	6.2	UCPX12-207D1	16.0	UELPL205-100D1	2.0
UCP205-015D1	UCP307-104D1	6.2	UCPX13D1	17.0	UELPL206D1	3.1
UCP205-100D1	UCP307-105D1	6.2	UCPX13-208D1	17.0	UELPL206-101D1	3.1
UCP206D1	UCP307-106D1	6.2	UCPX13-209D1	17.0	UELPL206-102D1	3.1
UCP206-101D1	UCP307-107D1	6.2	UCPX14D1	22.0	UELPL206-103D1	3.1
UCP206-102D1	UCP308D1	6.6	UCPX14-210D1	22.0	UELPL206-104D1	3.1
UCP206-103D1	UCP308-108D1	6.6	UCPX14-211D1	22.0	UELPL207D1	4.0
UCP206-104D1	UCP309D1	9.0	UCPX14-212D1	22.0	UELPL207-104D1	4.0
UCP207D1	UCP309-110D1	9.0	UCPX15D1	24.0	UELPL207-105D1	4.0
UCP207-104D1	UCP309-111D1	9.0	UCPX15-213D1	24.0	UELPL207-106D1	4.0
UCP207-105D1	UCP309-112D1	9.0	UCPX15-214D1	24.0	UELPL207-107D1	4.0
UCP207-106D1	UCP310D1	0.1	UCPX15-215D1	24.0	UELPL208D1	4.4
UCP207-107D1	UCP310-114D1	13.0	UCPX15-300D1	24.0	UELPL208-108D1	4.4
UCP208D1	UCP310-115D1	13.0	UCPX16D1	33.0	UELPL208109D1	4.4
UCP208-108D1	UCP311D1	16.0	UCPX16-302D1	33.0	UELPL209D1	5.3
UCP208-109D1	UCP311-200D1	16.0	UCPX16-303D1	33.0	UELPL209-110D1	5.3
UCP209D1	UCP311-202D1	16.0	UCPX16-304D1	33.0	UELPL209-111D1	5.3
UCP209-110D1	UCP311-203D1	16.0	UCPX17D1	35.0	UELPL209-112D1	5.3
UCP209-111D1	UCP312D1	21.0	UCPX17-305D1	35.0	UELPL210D1	6.2
UCP209-112D1	UCP312-204D1	21.0	UCPX17-307D1	35.0	UELPL210-113D1	6.2
UCP210D1	UCP312-206D1	21.0	UCPX18D1	37.0	UELPL210-114D1	6.2
UCP210-113D1	UCP312-207D1	21.0	UCPX18-308D1	37.0	UELPL210-115D1	6.2
UCP210-114D1	UCP313D1	22.0	UCPX20D1	66.0	UELPL210-115D1	6.2
UCP210-115D1	UCP313-208D1	22.0	UCPX20-314D1	66.0	UELPL210-200D1	6.2
UCP210-200D1	UCP314D1	26.0	UCPX20-315D1	66.0	UELPL211D1	7.7
UCP211D1	UCP314-211D1	26.0	UCPX20-400D1	66.0	UELPL211-200D1	7.7
UCP211-200D1	UCP314-212D1	26.0	ASPL2 SERIES		UELPL211-201D1	7.7
UCP211-201D1	UCP315D1	31.0	ASPL201	1.3	UELPL211-202D1	7.7
UCP211-202D1	UCP315-215D1	31.0	ASPL201-008	1.3	UELPL211-203D1	7.7
UCP211-203D1	UCP315-300D1	31.0	ASPL202	1.3	UELPL212D1	11.0
UCP212D1	UCP316D1	40.0	ASPL202-009	1.3	UELPL212-204D1	11.0
UCP212-204D1	UCP316-302D1	40.0	ASPL202-010	1.3	UELPL212-206D1	11.0
UCP212-206D1	UCP316-303D1	40.0	ASPL203	1.1	UELPL212-207D1	11.0
UCP212-207D1	UCP317D1	44.0	ASPL203-011	1.1	UELPL213D1	14.0
UCP213D1	UCP317-304D1	44.0	ASPL204	1.3	UELPL213-208D1	14.0
UCP213-208D1	UCP318D1	53.0	ASPL204-012	1.3	UELPL214D1	15.0
UCP214D1	UCP318-307D1	53.0	ASPL205	1.5	UELPL214-211D1	15.0
UCP214-211D1	UCP318-308D1	53.0	ASPL205-013	1.5	UELPL214-212D1	15.0
UCP214-212D1	UCP319D1	64.0	ASPL205-014	1.5	UELPL215D1	17.0
UCP215D1	UCP319-312D1	64.0	ASPL205-015	1.5	UELPL215-215D1	17.0
UCP215-215D1	UCP320D1	77.0	ASPL205-100	1.5	UELPL215-300D1	17.0
UCP215-300D1	UCP320-315D1	77.0	ASPL206	2.6	UELPL2 SERIES	
UCP216D1	UCP320-400D1	77.0	ASPL206-101	2.6	UELPL204D1	1.5
UCP216-302D1	UCP321D1	77.0	ASPL206-103	2.6	UELPL204-012D1	1.5
UCP217D1	UCP322D1	99.0	ASPL206-104	2.6	UELPL205D1	1.8
UCP217-304D1	UCP324D1	121.0	ASPL207	3.3	UELPL205-013D1	1.8
UCP218D1	UCP326D1	159.0	ASPL207-104	3.3	UELPL205-014D1	1.8
UCP218-308D1	UCP328D1	196.0	ASPL207-105	3.3	UELPL205-015D1	1.8
UCPL2 SERIES	UCPX SERIES		ASPL207-106	3.3	UELPL205-100D1	1.8
UCPL204D1	UCPX05D1	3.3	ASPL207-107	3.3	UELPL206D1	3.1
UCPL204-012D1	UCPX05-013D1	3.3	ASPP2 SERIES		UELPL206-101D1	3.1
UCPL205D1	UCPX05-014D1	3.3	ASPP201	0.4	UELPL206-102D1	3.1
UCPL205-013D1	UCPX05-015D1	3.3	ASPP201-008	0.4	UELPL206-103D1	3.1
UCPL205-014D1	UCPX05-100D1	3.3	ASPP202	0.2	UELPL206-104D1	3.1
UCPL205-015D1	UCPX06D1	4.4	ASPP202-009	0.2	UELPL207D1	3.7
UCPL205-100D1	UCPX06-101D1	4.4	ASPP202-010	0.2	UELPL207-104D1	3.7
UCPL206D1	UCPX06-102D1	4.4	ASPP203	0.2	UELPL207-105D1	3.7
UCPL206-101D1	UCPX06-103D1	4.4	ASPP203-011	0.2	UELPL207-106D1	3.7
UCPL206-102D1	UCPX06-104D1	4.4	ASPP204	0.4	UELPL207-107D1	3.7
UCPL206-103D1	UCPX07D1	5.7	ASPP204-012	0.4	UELPL209D1	5.1
UCPL206-104D1	UCPX07-105D1	5.7	ASPP205	0.7	UELPL209-110D1	5.1
UCPL207D1	UCPX07-106D1	5.7	ASPP205-013	0.7	UELPL209-111D1	5.1
UCPL207-104D1	UCPX07-107D1	5.7	ASPP205-014	0.7	UELPL209-112D1	5.1
UCPL207-105D1	UCPX08D1	7.3	ASPP205-015	0.7	UELPL210D1	6.0
UCPL207-106D1	UCPX08-108D1	7.3	ASPP205-100	0.7	UELPL210-113D1	6.0
UCPL207-107D1	UCPX08-109D1	7.3	ASPP206	0.9	UELPL210-114D1	6.0
UCPL209D1	UCPX09D1	7.3	ASPP206-101	0.9	UELPL210-115D1	6.0
UCPL209-110D1	UCPX09-110D1	7.3	ASPP206-102	0.9	UELPL210-200D1	6.0
UCPL209-111D1	UCPX09-111D1	7.3	ASPP206-103	0.9	UELPL3 SERIES	
UCPL209-112D1	UCPX09-112D1	7.3	ASPP206-104	0.9	UELPL305D1	3.1
UCPL210D1					UELPL305-014D1	3.1



Bearing Series → UCP2 SERIES

UCP201D1 1.5

Complete Pillow Block Number

Weight (lbs)

GREENLINE PILLOW BLOCKS		LBS.
UEL305-015D1 3.1	AELP205-015D1 1.9	UKP208D1:HE2308X 4.4
UEL305-100D1 3.1	AELP205-100D1 1.9	UKP208D1:HS2308X 4.4
UEL306D1 4.2	AELP206D1 2.8	UKP209D1:H2309X 5.1
UEL306-102D1 4.2	AELP206-101D1 2.8	UKP209D1:HA2309 5.1
UEL306-103D1 4.2	AELP206-102D1 2.8	UKP209D1:HE2309X 5.1
UEL307D1 6.4	AELP206-103D1 2.8	UKP209D1:HS2309X 5.1
UEL307-104D1 6.4	AELP206-104D1 2.8	UKP210D1:H2310X 6.2
UEL307-105D1 6.4	AELP207D1 3.7	UKP210D1:HS2310 6.2
UEL307-106D1 6.4	AELP207-104D1 3.8	UKP210D1:HA2310 6.2
UEL307-107D1 6.4	AELP207-105D1 3.8	UKP210D1:HE2310X 6.2
UEL308D1 6.8	AELP207-106D1 3.8	UKP211D1:H2311X 7.7
UEL308-108D1 6.8	AELP207-107D1 3.8	UKP211D1:HS2311 7.7
UEL309D1 9.5	AELP208D1 4.2	UKP211D1:HA2311 7.7
UEL309-110D1 9.5	AELP208-108D1 4.2	UKP211D1:HE2311XY 7.7
UEL309-111D1 9.5	AELP208-109D1 4.2	UKP212D1:H2312X 10.0
UEL309-112D1 9.5	AELP209D1 4.9	UKP212D1:HS2312 10.0
UEL310D1 13.0	AELP209-110D1 4.9	UKP213D1:H2313X 13.0
UEL310-114D1 13.0	AELP209-111D1 4.9	UKP213D1:HA2313X 13.0
UEL310-115D1 13.0	AELP209-112D1 4.9	UKP213D1:HE2313 13.0
UEL311D1 17.0	AELP210D1 5.8	UKP213D1:HS2313 13.0
UEL311-200D1 17.0	AELP210-113D1 5.8	UKP215D1:H2315X 17.0
UEL311-202D1 17.0	AELP210-114D1 5.8	UKP215D1:HA2315 17.0
UEL311-203D1 17.0	AELP210-115D1 5.8	UKP215D1:HE2315 17.0
UEL312D1 21.0	AELPL2 SERIES	UKP216D1:H2316 21.0
UEL312-204D1 21.0	AELPL201 1.3	UKP216D1:HA2316 21.0
UEL312-206D1 21.0	AELPL201-008 1.3	UKP216D1:HE2316 21.0
UEL312-207D1 21.0	AELPL202 1.3	UKP217D1:H2317X 26.0
UEL313D1 24.0	AELPL202-009 1.3	UKP217D1:HA2317 26.0
UEL313-208D1 24.0	AELPL202-010 1.3	UKP217D1:HE2317 26.0
UEL314D1 26.0	AELPL203 1.3	UKP218D1:H2318X 31.0
UEL314-211D1 26.0	AELPL203-011 1.3	UKP218D1:HA2318 31.0
UEL314-212D1 26.0	AELPL204 1.5	
UEL315D1 33.0	AELPL204-012 1.5	
UEL315-215D1 33.0	AELPL205 1.8	
UEL315-300D1 33.0	AELPL205-013 1.8	
UEL316D1 42.0	AELPL205-014 1.8	
UEL316-302D1 42.0	AELPL205-015 1.8	
UEL316-303D1 42.0	AELPL205-100 1.8	
UEL317D1 46.0	AELPL206 2.6	
UEL317-304D1 46.0	AELPL206-101 2.6	
UEL318D1 55.0	AELPL206-102 2.6	
UEL318-307D1 55.0	AELPL206-103 2.6	
UEL318-308D1 55.0	AELPL206-104 2.6	
UEL319D1 66.0	AELPL207 3.5	
UEL319-312D1 66.0	AELPL207-104 3.5	
UEL320D1 82.0	AELPL207-105 3.5	
UEL320-315D1 82.0	AELPL207-106 3.5	
UEL320-315D1 82.0	AELPL207-107 3.5	
UEL320-400D1 82.0	AELPP2 SERIES	
UEL321D1 82.0	AELPP201 0.4	
UEL322D1 106.0	AELPP201-008 0.4	
JELPL2 SERIES	AELPP202 0.4	
JELPL201 1.3	AELPP202-009 0.4	
JELPL201-008 1.3	AELPP202-010 0.4	
JELPL202 1.3	AELPP203 0.4	
JELPL202-009 1.3	AELPP203-011 0.4	
JELPL202-010 1.3	AELPP204 0.4	
JELPL203 1.3	AELPP204-012 0.4	
JELPL203-011 1.3	AELPP205 0.7	
JELPL204 1.5	AELPP205-013 0.7	
JELPL204-012 1.5	AELPP205-014 0.7	
JELPL205 1.8	AELPP205-015 0.7	
JELPL205-013 1.8	AELPP205-100 0.7	
JELPL205-014 1.8	AELPP206 1.1	
JELPL205-015 1.8	AELPP206-101 1.1	
JELPL205-100 1.8	AELPP206-102 1.1	
JELPL206 2.6	AELPP206-103 1.1	
JELPL206-101 2.6	AELPP206-104 1.1	
JELPL206-102 2.6	AELPP207 1.5	
JELPL206-103 2.6	AELPP207-104 1.5	
JELPL206-104 2.6	AELPP207-105 1.5	
JELPL207 3.5	AELPP207-106 1.5	
JELPL207-104 3.5	AELPP207-107 1.5	
JELPL207-105 3.5	UKP2 SERIES	
JELPL207-106 3.5	UKP205D1:H2305X 2.0	
JELPL207-107 3.5	UKP205D1:HE2305 2.0	
AELP2 SERIES	UKP206D1:H2306X 2.9	
AELP204D1 1.5	UKP206D1:HS2306 2.9	
AELP204-012D1 1.5	UKP206D1:HE2306X 2.9	
AELP205D1 1.9	UKP207D1:H2307X 3.7	
AELP205-013D1 1.9	UKP207D1:HS2307 3.7	
AELP205-014D1 1.9	UKP208D1:HS2308X 4.4	



Units: Millimeters
INCHES

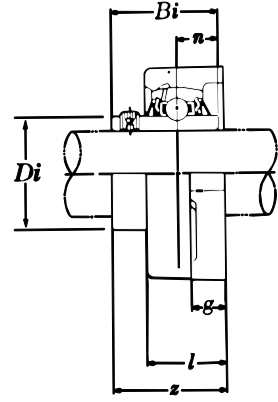
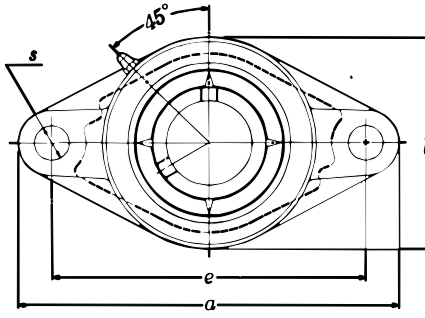

FLANGED UNITS - CAST HOUSING (TWO BOLT)

Shaft Dia.	Complete Flanged Unit Number	Nominal Dimensions									Bolt Size	Housing Number	Bearing Number	Basic Load Ratings (lbs)	
		a	e	g	l	s	b	z	Bi	n				Dynamic C	Static Co
12 ½	UCFL201D1 UCFL201-008D1	113 4 ⅞	90 3 ¾	11 ⅞	25.5 1	12 15/32	60 2 ¾	33.3 1 ⅞	31 1.220	12.7 .500	M10 ⅝	FL204D1 FL204D1	UC201D1 UC201-008D1	2,890	1,500
15 ⅝ 5/8	UCFL202D1 UCFL202-009D1 UCFL202-010D1	113 4 ⅞	90 3 ¾	11 ⅞	25.5 1	12 25/64	60 2 ¾	33.3 1 ⅞	31 1.220	12.7 .500	M10 ⅝	FL204D1 FL204D1 FL204D1	UC202D1 UC202-009D1 UC202-010D1	2,890	1,500
17 1 1/16	UCFL203D1 UCFL203-011D1	113 4 ⅞	90 3 ¾	11 ⅞	25.5 1	12 25/64	60 2 ¾	33.3 1 ⅞	31 1.220	12.7 .500	M10 ⅝	FL204D1 FL204D1	UC203D1 UC203-011D1	2,890	1,500
20 ¾	UCFL204D1 UCFL204-012D1	113 4 ⅞	90 3 ¾	11 ⅞	25.5 1	12 25/64	60 2 ¾	33.3 1 ⅞	31 1.220	12.7 .500	M10 ⅝	FL204D1 FL204D1	UC204D1 UC204-012D1	2,890	1,500
25 1 3/16 7/8 1 1/8 1 1/4	UCFL205D1 UCFL205-013D1 UCFL205-014D1 UCFL205-015D1 UCFL205-100D1	130 5 ½	99 3 5/8	13 ½	27 1 1/16	16 5/8	68 2 1/16	35.7 1 13/32	34 1.339	14.3 .563	M14 ¾	FL205D1 FL205D1 FL205D1 FL205D1 FL205D1	UC205D1 UC205-013D1 UC205-014D1 UC205-015D1 UC205-100D1	3,150	1,770
30 1 1/16 1 1/8 1 3/16 1 1/4	UCFL206D1 UCFL206-101D1 UCFL206-102D1 UCFL206-103D1 UCFL206-104D1	148 5 13/16	117 4 3/8	13 ½	31 1 1/32	16 5/8	80 3 1/2	40.2 1 37/64	38.1 1.500	15.9 .626	M14 ¾	FL206D1 FL206D1 FL206D1 FL206D1 FL206D1	UC206D1 UC206-101D1 UC206-102D1 UC206-103D1 UC206-104D1	4,400	2,540
35 1 1/4 1 5/16 1 3/8 1 7/16	UCFL207D1 UCFL207-104D1 UCFL207-105D1 UCFL207-106D1 UCFL207-107D1	161 6 1/32	130 5 1/8	15 1 9/32	34 1 1/32	16 5/8	90 3 1/2	44.4 1 3/4	42.9 1.689	17.5 .689	M14 7/16	FL207D1 FL207D1 FL207D1 FL207D1 FL207D1	UC207D1 UC207-104D1 UC207-105D1 UC207-106D1 UC207-107D1	5,750	3,440
40 1 1/2 1 9/16	UCFL208D1 UCFL208-108D1 UCFL208-109D1	175 6 7/8	144 5 43/64	15 1 9/32	36 1 1/32	16 5/8	100 3 15/16	51.2 2 1/4	49.2 1.937	19 .748	M14 7/16	FL208D1 FL208D1 FL208D1	UC208D1 UC208-108D1 UC208-109D1	6,550	4,000
45 1 5/8 1 11/16 1 3/4	UCFL209D1 UCFL209-110D1 UCFL209-111D1 UCFL209-112D1	188 7 13/32	148 5 53/64	16 5/8	38 1 1/2	19 3/4	108 4 1/4	52.2 2 1/16	49.2 1.937	19 .748	M16 ½	FL209D1 FL209D1 FL209D1 FL209D1	UC209D1 UC209-110D1 UC209-111D1 UC209-112D1	7,350	4,590
50 1 13/16 1 7/8 1 15/16 2	UCFL210D1 UCFL210-113D1 UCFL210-114D1 UCFL210-115D1 UCFL210-200D1	197 7 3/4	157 6 3/16	16 5/8	40 1 9/16	19 3/4	115 4 17/32	54.6 2 5/32	51.6 2.031	19 .748	M16 ½	FL210D1 FL210D1 FL210D1 FL210D1 FL210D1	UC210D1 UC210-113D1 UC210-114D1 UC210-115D1 UC210-200D1	7,900	5,220
55 2 2 1/16 2 1/8 2 3/16	UCFL211D1 UCFL211-200D1 UCFL211-201D1 UCFL211-202D1 UCFL211-203D1	224 8 13/16	184 7 1/4	18 23/32	43 1 11/16	19 3/4	130 5 1/8	58.4 2 19/64	55.6 2.189	22.2 .874	M16 9/16	FL211D1 FL211D1 FL211D1 FL211D1 FL211D1	UC211D1 UC211-200D1 UC211-201D1 UC211-202D1 UC211-203D1	9,750	6,570
60 2 1/4 2 3/8 2 7/16	UCFL212D1 UCFL212-204D1 UCFL212-206D1 UCFL212-207D1	250 9 27/32	202 7 61/64	18 23/32	48 1 7/8	23 29/32	140 5 1/2	68.7 2 49/64	65.1 2.563	25.4 1.000	M20 ¾	FL212D1 FL212D1 FL212D1 FL212D1	UC212D1 UC212-204D1 UC212-206D1 UC212-207D1	11,800	8,100
65 2 1/2	UCFL213D1 UCFL213-208D1	258 10 9/32	210 8 17/64	22 7/8	50 1 31/32	23 29/32	155 6 3/32	69.7 2 3/4	65.1 2.563	25.4 1.000	M20 ¾	FL213D1 FL213D1	UC213D1 UC213-208D1	12,900	9,000
70 2 11/16 2 3/4	UCFL214D1 UCFL214-211D1 UCFL214-212D1	265 10 7/16	216 8 1/2	22 7/8	54 2 1/8	23 29/32	160 6 3/16	75.4 2 31/32	74.6 2.937	30.2 1.189	M20 ¾	FL214D1 FL214D1 FL214D1	UC214D1 UC214-211D1 UC214-212D1	14,000	9,900
75 2 15/16 3	UCFL215D1 UCFL215-215D1 UCFL215-300D1	275 10 13/16	225 8 59/64	22 7/8	56 2 1/32	23 29/32	165 6 1/2	78.5 3 3/32	77.8 3.063	33.3 1.311	M20 ¾	FL215D1 FL215D1 FL215D1	UC215D1 UC215-215D1 UC215-300D1	14,900	11,100
80 3 1/8	UCFL216D1 UCFL216-302D1	290 11 13/32	233 9 11/64	22 7/8	58 2 9/32	25 63/64	180 7 3/32	83.3 3 9/32	82.6 3.252	33.3 1.311	M22 7/8	FL216D1 FL216D1	UC216D1 UC216-302D1	16,300	11,900
85 3 1/4	UCFL217D1 UCFL217-304D1	305 12	248 9 49/64	24 15/16	63 2 15/32	25 63/64	190 7 15/32	87.6 3 29/64	85.7 3.374	34.1 1.343	M22 7/8	FL217D1 FL217D1	UC217D1 UC217-304D1	18,700	14,400
90 3 1/2	UCFL218D1 UCFL218-308D1	320 12 19/32	265 10 7/16	24 15/16	68 2 11/16	25 63/64	205 8 1/16	96.3 3 51/64	96 3.780	39.7 1.563	M22 7/8	FL218D1 FL218D1	UC218D1 UC218-308D1	21,600	16,100

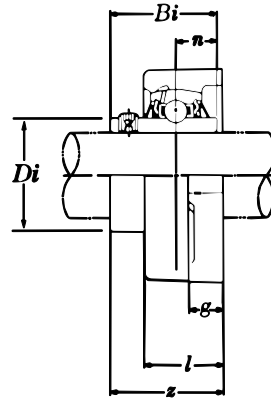
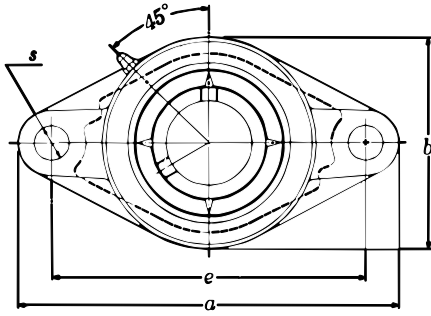

Units: Millimeters
INCHES

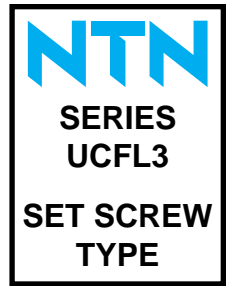

FLANGED UNITS - CAST HOUSING (TWO BOLT)

Shaft Dia.	Complete Flanged Unit Number	Nominal Dimensions									Bolt Size	Housing Number	Bearing Number	Basic Load Ratings (lbs)	
		a	e	g	l	s	b	z	Bi	n				Dynamic C	Static Co
25 7/8 1 1/16 1	UCFL305D1 UCFL305-014D1 UCFL305-015D1 UCFL305-100D1	150 5 29/32	113 4 7/16	13 1/2	29 1 1/32	19 3/4	80 3 3/32	39 1 17/32	38 1.496	15 .591	M16 5/8	FL305D1 FL305D1 FL305D1 FL305D1	UC305D1 UC305-014D1 UC305-015D1 UC305-100D1	4,750	2,460
30 1 1/8 1 3/16	UCFL306D1 UCFL306-102D1 UCFL306-103D1	180 7 3/32	134 5 3/32	15 19/32	32 1 1/4	23 29/32	90 3 17/32	44 1 47/64	43 1.693	17 .669	M20 3/4	FL306D1 FL306D1 FL306D1	UC306D1 UC306-102D1 UC306-103D1	6,000	3,400
35 1 1/4 1 5/16 1 3/8 1 7/16	UCFL307D1 UCFL307-104D1 UCFL307-105D1 UCFL307-106D1 UCFL307-107D1	185 7 9/32	141 5 32/64	16 5/8	36 1 13/32	23 29/32	100 3 15/16	49 1 59/64	48 1.890	19 .748	M20 3/4	FL307D1 FL307D1 FL307D1 FL307D1 FL307D1	UC307D1 UC307-104D1 UC307-105D1 UC307-106D1 UC307-107D1	7,500	4,300
40 1 1/2	UCFL308D1 UCFL308-108D1	200 7 7/8	158 6 7/32	17 2 1/32	40 1 9/16	23 29/32	112 4 13/32	56 2 13/64	52 2.047	19 .748	M20 3/4	FL308D1 FL308D1	UC308D1 UC308-108D1	9,150	5,400
45 1 5/8 1 1 1/16 1 3/4	UCFL309D1 UCFL309-110D1 UCFL309-111D1 UCFL309-112D1	230 9 1/16	177 6 31/32	18 23/32	44 1 23/32	25 63/64	125 4 29/32	60 2 23/64	57 2.244	22 .866	M22 7/8	FL309D1 FL309D1 FL309D1 FL309D1	UC309D1 UC309-110D1 UC309-111D1 UC309-112D1	11,900	7,200
50 1 7/8 1 1 9/16	UCFL310D1 UCFL310-114D1 UCFL310-115D1	240 9 7/16	187 7 23/64	19 3/4	48 1 7/8	25 63/64	140 5 1/2	67 2 41/64	61 2.402	22 .866	M22 7/8	FL310D1 FL310D1 FL310D1	UC310D1 UC310-114D1 UC310-115D1	13,900	8,600
55 2 2 1/8 2 3/16	UCFL311D1 UCFL311-200D1 UCFL311-202D1 UCFL311-203D1	250 9 27/32	198 7 51/64	20 29/32	52 2 1/16	25 63/64	150 5 29/32	71 2 51/64	66 2.598	25 .984	M22 7/8	FL311D1 FL311D1 FL311D1 FL311D1	UC311D1 UC311-200D1 UC311-202D1 UC311-203D1	16,100	10,100
60 2 1/4 2 3/8 2 7/16	UCFL312D1 UCFL312-204D1 UCFL312-206D1 UCFL312-207D1	270 10 5/8	212 8 1 1/32	22 7/8	56 2 7/32	31 1 7/32	160 6 9/16	78 3 3/64	71 2.795	26 1.024	M27 1	FL312D1 FL312D1 FL312D1 FL312D1	UC312D1 UC312-204D1 UC312-206D1 UC312-207D1	18,400	11,700
65 2 1/2	UCFL313D1 UCFL313-208D1	295 11 5/8	240 9 29/64	25 3 1/32	58 2 9/32	31 1 7/32	175 6 7/8	78 3 3/64	75 2.953	30 1.181	M27 1	FL313D1 FL313D1	UC313D1 UC313-208D1	20,800	13,400
70 2 1 1/16 2 3/4	UCFL314D1 UCFL314-211D1 UCFL314-212D1	315 12 13/32	250 9 27/32	28 1 3/32	61 2 13/32	35 1 3/8	185 7 3/32	81 3 3/16	78 3.071	33 1.299	M30 1 1/8	FL314D1 FL314D1 FL314D1	UC314D1 UC314-211D1 UC314-212D1	23,400	15,300
75 2 1 9/16 3	UCFL315D1 UCFL315-215D1 UCFL315-300D1	320 12 19/32	260 10 15/64	30 1 3/16	66 2 19/32	35 1 3/8	195 7 11/16	89 3 1/2	82 3.228	32 1.260	M30 1 1/8	FL315D1 FL315D1 FL315D1	UC315D1 UC315-215D1 UC315-300D1	25,500	17,400
80 3 1/8 3 3/16	UCFL316D1 UCFL316-302D1 UCFL316-303D1	355 13 31/32	285 11 7/32	32 1 1/4	68 2 1 1/16	38 1 1/2	210 8 3/32	90 3 39/64	86 3.386	34 1.339	M33 1 1/4	FL316D1 FL316D1 FL316D1	UC316D1 UC316-302D1 UC316-303D1	27,600	19,500
85 3 1/4	UCFL317D1 UCFL317-304D1	370 14 9/16	300 11 13/16	32 1 1/4	74 2 29/32	38 1 1/2	220 8 2 1/32	100 3 15/16	96 3.780	40 1.575	M33 1 1/4	FL317D1 FL317D1	UC317D1 UC317-304D1	29,800	21,800
90 3 7/16 3 1/2	UCFL318D1 UCFL318-307D1 UCFL318-308D1	385 15 5/32	315 12 13/32	36 1 13/32	76 3	38 1 1/2	235 9 1/4	100 3 15/16	96 3.780	40 1.575	M33 1 1/4	FL318D1 FL318D1 FL318D1	UC318D1 UC318-307D1 UC318-308D1	32,000	24,100
95 3 3/4	UCFL319D1 UCFL319-312D1	405 15 15/16	330 13	40 1 9/16	94 3 1 1/16	41 1 39/64	250 9 27/32	121 4 49/64	103 4.055	41 1.614	M36 1 3/8	FL319D1 FL319D1	UC319D1 UC319-312D1	34,500	26,600
100 3 1 9/16 4	UCFL320D1 UCFL320-315D1 UCFL320-400D1	440 17 5/16	360 14 1 1/64	40 2 2 1/64	94 3 1 1/16	44 1 47/64	270 10 5/8	125 4 59/64	108 4.252	42 1.654	M39 1 1/2	FL320D1 FL320D1 FL320D1	UC320D1 UC320-315D1 UC320-400D1	39,000	31,500
105	UCFL321D1	440	360	40	94	44	270	127	112	44	M39	FL321D1	UC321D1	41,500	34,500
110	UCFL322D1	470	390	42	96	44	300	131	117	46	M39	FL322D1	UC322D1	46,000	40,500
120	UCFL324D1	520	430	48	110	47	330	140	126	51	M42	FL324D1	UC324D1	46,500	41,500
130	UCFL326D1	550	460	50	115	47	360	146	135	54	M42	FL326D1	UC326D1	51,500	48,000
140	UCFL328D1	600	500	60	125	51	400	161	145	59	M45	FL328D1	UC328D1	57,000	55,500

NTN
SERIES UCFLX
SET SCREW TYPE

Units: Millimeters
 INCHES

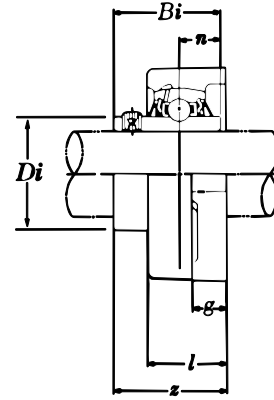
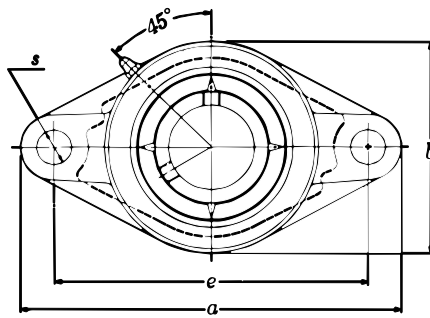

FLANGED UNITS - CAST HOUSING (TWO BOLT)

Shaft Dia.	Complete Flanged Unit Number	Nominal Dimensions									Bolt Size	Housing Number	Bearing Number	Basic Load Ratings (lbs)	
		a	e	g	l	s	b	z	B_i	n				Dynamic C	Static C_o
25 $1\frac{3}{16}$ $\frac{7}{8}$ $1\frac{5}{16}$ 1	UCFLX05D1 UCFLX05-013D1 UCFLX05-014D1 UCFLX05-015D1 UCFLX05-100D1	141 $5\frac{3}{16}$	117 $4\frac{39}{64}$	13 $\frac{1}{2}$	30 $1\frac{3}{16}$	12 $1\frac{1}{32}$	83 $3\frac{9}{32}$	40.2 $1\frac{37}{64}$	38.1 1.500	15.9 .626	M10 $\frac{3}{8}$	FLX05D1 FLX05D1 FLX05D1 FLX05D1 FLX05D1	UCX05D1 UCX05-013D1 UCX05-014D1 UCX05-015D1 UCX05-100D1	4,390	2,540
30 $1\frac{1}{16}$ $1\frac{1}{8}$ $1\frac{3}{16}$ $1\frac{1}{4}$	UCFLX06D1 UCFLX06-101D1 UCFLX06-102D1 UCFLX06-103D1 UCFLX06-104D1	156 $6\frac{5}{32}$	130 $5\frac{1}{8}$	15 $1\frac{1}{32}$	34 $1\frac{11}{32}$	16 $\frac{5}{8}$	95 $3\frac{3}{4}$	44.4 $1\frac{3}{4}$	42.9 1.689	17.5 .689	M14 $\frac{1}{2}$	FLX06D1 FLX06D1 FLX06D1 FLX06D1 FLX06D1	UCX06D1 UCX06-101D1 UCX06-102D1 UCX06-103D1 UCX06-104D1	5,780	3,440
35 $1\frac{5}{16}$ $1\frac{3}{8}$ $1\frac{7}{16}$	UCFLX07D1 UCFLX07-105D1 UCFLX07-106D1 UCFLX07-107D1	171 $6\frac{23}{32}$	144 $5\frac{43}{64}$	16 $\frac{5}{8}$	38 $1\frac{1}{2}$	16 $\frac{5}{8}$	105 $4\frac{1}{8}$	51.2 $2\frac{1}{64}$	49.2 1.937	19 .748	M14 $\frac{1}{2}$	FLX07D1 FLX07D1 FLX07D1 FLX07D1	UCX07D1 UCX07-105D1 UCX07-106D1 UCX07-107D1	6,550	4,000
40 $1\frac{1}{2}$ $1\frac{9}{16}$	UCFLX08D1 UCFLX08-108D1 UCFLX08-109D1	179 $7\frac{1}{16}$	148 $5\frac{53}{64}$	16 $\frac{5}{8}$	40 $1\frac{1}{16}$	16 $\frac{5}{8}$	111 $4\frac{3}{8}$	52.2 $2\frac{1}{16}$	49.2 1.937	19 .748	M14 $\frac{1}{2}$	FLX08D1 FLX08D1 FLX08D1	UCX08D1 UCX08-108D1 UCX08-109D1	7,310	4,590
45 $1\frac{5}{8}$ $1\frac{11}{16}$ $1\frac{3}{4}$ $1\frac{13}{16}$	UCFLX09D1 UCFLX09-110D1 UCFLX09-111D1 UCFLX09-112D1 UCFLX09-113D1	189 $7\frac{7}{16}$	157 $6\frac{3}{16}$	16 $\frac{5}{8}$	40 $1\frac{9}{16}$	16 $\frac{5}{8}$	116 $4\frac{9}{16}$	55.6 $2\frac{3}{16}$	51.6 2.031	19 .748	M14 $\frac{1}{2}$	FLX09D1 FLX09D1 FLX09D1 FLX09D1 FLX09D1	UCX09D1 UCX09-110D1 UCX09-111D1 UCX09-112D1 UCX09-113D1	7,870	5,220
50 $1\frac{7}{8}$ $1\frac{15}{16}$ 2	UCFLX10D1 UCFLX10-114D1 UCFLX10-115D1 UCFLX10-200D1	216 $8\frac{1}{2}$	184 $7\frac{1}{4}$	18 $2\frac{3}{32}$	44 $1\frac{23}{32}$	19 $\frac{3}{4}$	133 $5\frac{1}{4}$	59.4 $2\frac{11}{32}$	55.6 2.189	22.2 .874	M16 $\frac{5}{8}$	FLX10D1 FLX10D1 FLX10D1 FLX10D1	UCX10D1 UCX10-114D1 UCX10-115D1 UCX10-200D1	9,780	6,570

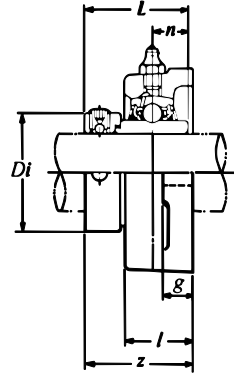
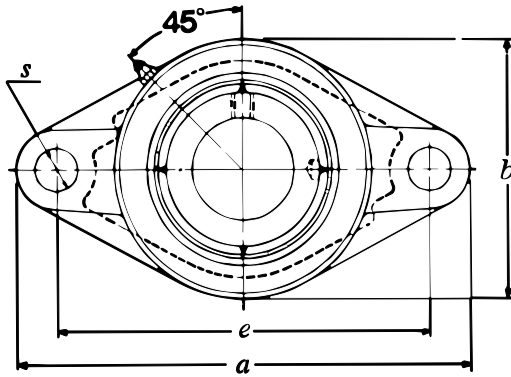

Units: Millimeters
INCHES



FLANGED UNITS - CAST HOUSING (TWO BOLT)

Shaft Dia.	Complete Flanged Unit Number	Nominal Dimensions									Bolt Size	Housing Number	Bearing Number	Basic Load Ratings (lbs)	
		a	e	g	l	s	z	Bi	Di	n				Dynamic C	Static Co
20 3/4	UELFL204D1 UELFL204-012D1	113 4 7/16	90 3 39/64	11 7/16	25.5 1	12 15/32	41.6 1 4 1/64	43.7 1.720	33 1.299	17.1 .673	M10 5/16	FL204D1 FL204D1	UEL204D1 UEL204-012D1	2,890	1,500
25 1 13/16 7/8 1 15/16 1	UELFL205D1 UELFL205-013D1 UELFL205-014D1 UELFL205-015D1 UELFL205-100D1	130 5 1/8	99 3 57/64	13 1/2	27 1 1/16	16 5/8	42.9 1 11/16	44.4 1.748	38 1.496	17.5 .689	M14 3/8	FL205D1 FL205D1 FL205D1 FL205D1 FL205D1	UEL205D1 UEL205-013D1 UEL205-014D1 UEL205-015D1 UEL205-100D1	3,150	1,770
30 1 1/16 1 1/8 1 3/16 1 1/4	UELFL206D1 UELFL206-101D1 UELFL206-102D1 UELFL206-103D1 UELFL206-104D1	148 5 13/16	117 4 9/64	13 1/2	31 1 7/32	16 5/8	48.1 1 57/64	48.4 1.906	44.5 1.752	18.3 .720	M14 3/8	FL206D1 FL206D1 FL206D1 FL206D1 FL206D1	UEL206D1 UEL206-101D1 UEL206-102D1 UEL206-103D1 UEL206-104D1	4,400	2,540
35 1 1/4 1 5/16 1 3/8 1 7/16	UELFL207D1 UELFL207-104D1 UELFL207-105D1 UELFL207-106D1 UELFL207-107D1	161 6 13/32	130 5 1/8	15 19/32	34 1 11/32	16 5/8	51.3 2 1/64	51.1 2.012	55.5 2.185	18.8 .740	M14 7/16	FL207D1 FL207D1 FL207D1 FL207D1 FL207D1	UEL207D1 UEL207-104D1 UEL207-105D1 UEL207-106D1 UEL207-107D1	5,750	3,440
40 1 1/2 1 9/16	UELFL208D1 UELFL208-108D1 UELFL208-109D1	175 6 7/8	144 5 43/64	15 19/32	36 1 13/32	16 5/8	55.9 2 13/64	56.3 2.217	60 2.362	21.4 .843	M14 7/16	FL207D1 FL208D1 FL208D1	UEL208D1 UEL208-108D1 UEL208-109D1	6,550	4,000
45 1 5/8 1 11/16 1 3/4	UELFL209D1 UELFL209-110D1 UELFL209-111D1 UELFL209-112D1	188 7 13/32	148 5 53/64	16 5/8	38 1 1/2	19 3/4	56.9 2 15/64	56.3 2.217	63.5 2.500	21.4 .843	M16 1/2	FL209D1 FL209D1 FL209D1 FL209D1	UEL209D1 UEL209-110D1 UEL209-111D1 UEL209-112D1	7,350	4,590
50 1 13/16 1 7/8 1 15/16 2	UELFL210D1 UELFL210-113D1 UELFL210-114D1 UELFL210-115D1 UELFL210-200D1	197 7 3/4	157 6 3/16	16 5/8	40 1 9/16	19 3/4	60.1 2 29/64	62.7 2.469	69.5 2.736	24.6 .969	M16 1/2	FL210D1 FL210D1 FL210D1 FL210D1 FL210D1	UEL210D1 UEL210-113D1 UEL210-114D1 UEL210-115D1 UEL210-200D1	7,900	5,220
55 2 2 1/16 2 1/8 2 3/16	UELFL211D1 UELFL211-200D1 UELFL211-201D1 UELFL211-202D1 UELFL211-203D1	224 8 13/16	184 7 1/4	18 23/32	43 1 11/16	19 3/4	68.6 2 45/64	71.4 2.811	76 2.992	27.8 1.094	M16 9/16	FL211D1 FL211D1 FL211D1 FL211D1 FL211D1	UEL211D1 UEL211-200D1 UEL211-201D1 UEL211-202D1 UEL211-203D1	9,750	6,570
60 2 1/4 2 3/8 2 7/16	UELFL212D1 UELFL212-204D1 UELFL212-206D1 UELFL212-207D1	250 9 27/32	202 7 61/64	18 23/32	48 1 7/8	23 29/32	75.8 2 63/64	77.8 3.063	84 3.307	31 1.220	M20 3/4	FL212D1 FL212D1 FL212D1 FL212D1	UEL212D1 UEL212-204D1 UEL212-206D1 UEL212-207D1	11,800	8,100
65 2 1/2	UELFL213D1 UELFL213-208D1	258 10 5/32	210 8 17/64	22 7/8	50 1 31/32	23 29/32	81.55 3 13/64	85.7 3.374	97 3.819	34.15 1.344	M20 3/4	FL213D1 FL213D1	UEL213D1 UEL213-208D1	12,900	9,000
70 2 11/16 2 3/4	UELFL214D1 UELFL214-211D1 UELFL214-212D1	265 10 7/16	216 8 1/2	22 7/8	54 2 1/8	23 29/32	82.55 3 1/4	85.7 3.374	97 3.819	34.15 1.344	M20 3/4	FL214D1 FL214D1 FL214D1	UEL214D1 UEL214-211D1 UEL214-212D1	14,000	9,900
75 2 15/16 3	UELFL215D1 UELFL215-215D1 UELFL215-300D1	275 10 13/16	225 8 55/64	22 7/8	56 2 7/32	23 29/32	88.7 3 31/64	92 3.622	102 4.016	37.3 1.469	M20 3/4	FL215D1 FL215D1 FL215D1	UEL215D1 UEL215-215D1 UEL215-300D1	14,900	11,130

NTN
SERIES
UELFL3
ECCENTRIC
LOCKING
COLLAR
TYPE

Units: Millimeters
 INCHES

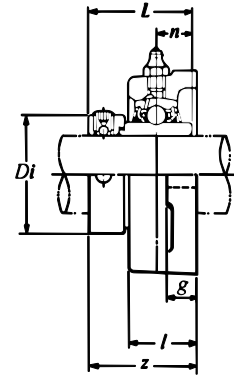
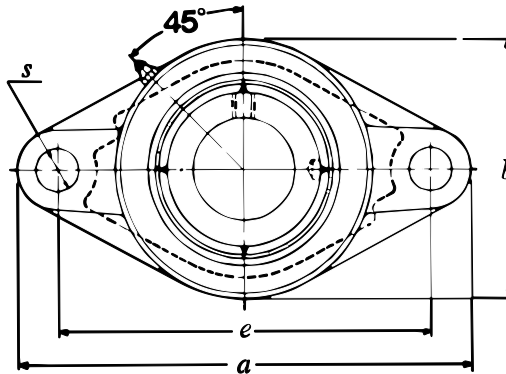

FLANGED UNITS - CAST HOUSING (TWO BOLT)

Shaft Dia.	Complete Flanged Unit Number	Nominal Dimensions									Bolt Size	Housing Number	Bearing Number	Basic Load Ratings (lbs)	
		<i>a</i>	<i>e</i>	<i>g</i>	<i>l</i>	<i>s</i>	<i>z</i>	<i>Bi</i>	<i>Di</i>	<i>n</i>				Dynamic <i>C</i>	Static <i>C₀</i>
25 7/8 15/16 1	UELFL305D1 UELFL305-014D1 UELFL305-015D1 UELFL305-100D1	150 5 29/32	113 4 29/64	13 1/2	29 1 1/32	19 3/4	46.1 1 19/16	46.8 1.843	42.8 1.685	16.7 .657	M16 5/8	FL305D1 FL305D1 FL305D1 FL305D1	UEL305D1 UEL305-014D1 UEL305-015D1 UEL305-100D1	4,750	2,460
30 1 1/8 1 3/16	UELFL306D1 UELFL306-102D1 UELFL306-103D1	180 7 3/32	134 5 9/32	15 19/32	32 1 1/4	23 29/32	50.5 1 63/64	50 1.969	50 1.969	17.5 .689	M20 3/4	FL306D1 FL306D1 FL306D1	UEL306D1 UEL306-102D1 UEL306-103D1	6,000	3,400
35 1 1/4 1 5/16 1 3/8 1 7/16	UELFL307D1 UELFL307-104D1 UELFL307-105D1 UELFL307-106D1 UELFL307-107D1	185 7 3/32	141 5 35/64	16 9/8	36 1 13/32	23 29/32	53.3 2 3/32	51.6 2.031	55 2.165	18.3 .720	M20 3/4	FL307D1 FL307D1 FL307D1 FL307D1 FL307D1	UEL307D1 UEL307-104D1 UEL307-105D1 UEL307-106D1 UEL307-107D1	7,500	4,300
40 1 1/2	UELFL308D1 UELFL308-108D1	200 7 7/8	158 6 7/32	17 21/32	40 1 9/16	23 29/32	60.3 3 3/8	57.1 2.248	63.5 2.500	19.8 .780	M20 3/4	FL308D1 FL308D1	UEL308D1 UEL308-108D1	9,150	5,400
45 1 5/8 1 11/16 1 3/4	UELFL309D1 UELFL309-110D1 UELFL309-111D1 UELFL309-112D1	230 9 1/16	177 6 31/32	18 23/32	44 1 23/32	25 63/64	63.9 2 33/64	58.7 2.311	70 2.756	19.8 .780	M22 7/8	FL309D1 FL309D1 FL309D1 FL309D1	UEL309D1 UEL309-110D1 UEL309-111D1 UEL309-112D1	11,900	7,200
50 1 7/8 1 15/16	UELFL310D1 UELFL310-114D1 UELFL310-115D1	240 9 7/16	187 7 23/64	19 3/4	48 1 7/8	25 63/64	70 2 3/4	66.6 2.622	76.2 3.000	24.6 .969	M22 7/8	FL310D1 FL310D1 FL310D1	UEL310D1 UEL310-114D1 UEL310-115D1	13,900	8,600
55 2 2 1/8 2 3/16	UELFL311D1 UELFL311-200D1 UELFL311-202D1 UELFL311-203D1	250 9 27/32	198 7 51/64	20 25/32	52 2 1/16	25 63/64	75.2 2 61/64	73 2.874	83 3.268	27.8 1.094	M22 7/8	FL311D1 FL311D1 FL311D1 FL311D1	UEL311D1 UEL311-200D1 UEL311-202D1 UEL311-203D1	16,100	10,100
60 2 1/4 2 3/8 2 7/16	UELFL312D1 UELFL312-204D1 UELFL312-206D1 UELFL312-207D1	270 10 9/8	212 8 11/32	22 7/8	56 2 7/32	31 1 7/32	81.45 3 13/64	79.4 3.126	89 3.504	30.95 1.219	M27 1	FL312D1 FL312D1 FL312D1 FL312D1	UEL312D1 UEL312-204D1 UEL312-206D1 UEL312-207D1	18,400	11,700
65 2 1/2	UELFL313D1 UELFL313-208D1	295 11 5/8	240 9 29/64	25 31/32	58 2 9/32	31 1 7/32	86.15 3 29/64	85.7 3.374	97 3.819	32.55 1.281	M27 1	FL313D1 FL313D1	UEL313D1 UEL313-208D1	20,800	13,400
70 2 11/16 2 3/4	UELFL314D1 UELFL314-211D1 UELFL314-212D1	315 12 13/32	250 9 27/32	28 1 3/32	61 2 13/32	35 1 3/8	93.95 3 45/64	92.1 3.626	102 4.016	34.15 1.344	M30 1 1/8	FL314D1 FL314D1 FL314D1	UEL314D1 UEL314-211D1 UEL314-212D1	23,400	15,300
75 2 15/16 3	UELFL315D1 UELFL315-215D1 UELFL315-300D1	320 12 19/32	260 10 15/16	30 1 3/16	66 2 19/32	35 1 3/8	101.7 4	100 3.937	113 4.449	37.3 1.469	M30 1 1/8	FL315D1 FL315D1 FL315D1	UEL315D1 UEL315-215D1 UEL315-300D1	25,500	17,400
80 3 1/8 3 3/16	UELFL316D1 UELFL316-302D1 UELFL316-303D1	355 13 31/32	285 11 7/32	32 1 1/4	68 2 11/16	38 1 1/2	103.9 4 3/32	106.4 4.189	119 4.685	40.5 1.594	M33 1 1/4	FL316D1 FL316D1 FL316D1	UEL316D1 UEL316-302D1 UEL316-303D1	27,600	19,500
85 3 1/4	UELFL317D1 UELFL317-304D1	370 14 9/16	300 11 13/16	32 1 1/4	74 2 29/32	38 1 1/2	111.45 4 25/64	109.5 4.311	127 5.000	42.05 1.656	M33 1 1/4	FL317D1 FL317D1	UEL317D1 UEL317-304D1	29,800	21,800
90 3 7/16 3 1/2	UELFL318D1 UELFL318-307D1 UELFL318-308D1	385 15 5/32	315 12 63/64	36 1 13/32	76 3	38 1 1/2	116.25 4 37/64	115.9 4.563	133 5.236	43.65 1.719	M33 1 1/4	FL318D1 FL318D1 FL318D1	UEL318D1 UEL318-307D1 UEL318-308D1	32,000	24,100
95 3 3/4	UELFL319D1 UELFL319-312D1	405 15 15/16	330 13	40 1 9/16	94 3 11/16	41 1 39/64	142.4 5 39/64	122.3 4.815	140 5.512	38.9 1.531	M36 1 3/8	FL319D1 FL319D1	UEL319D1 UEL319-312D1	34,500	26,600
100 3 15/16 4	UELFL320D1 UELFL320-315D1 UELFL320-400D1	440 17 5/16	360 14 11/64	40 1 9/16	94 3 11/16	44 1 47/64	137.6 5 27/64	128.6 5.063	146 5.748	50 1.969	M39 1 1/2	FL320D1 FL320D1 FL320D1	UEL320D1 UEL320-315D1 UEL320-400D1	39,000	31,500
105	UELFL321D1	440	360	40	94	44	150.3	139.7	157	48.4	M39	FL321D1	UEL321D1	41,500	34,500
110	UELFL322D1	470	390	42	96	44	152.1	141.3	168	49.2	M39	FL322D1	UEL322D1	46,000	40,500

Units: Millimeters
INCHES

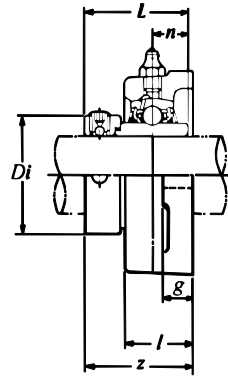
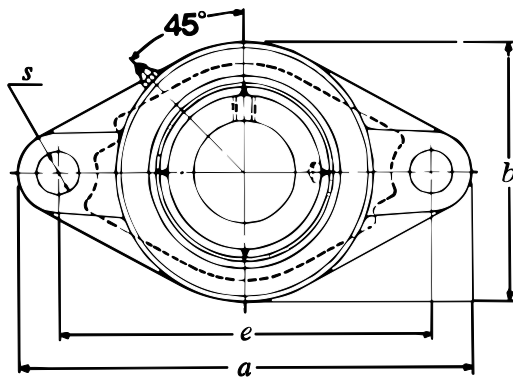

FLANGED UNITS - CAST HOUSING (TWO BOLT)

Shaft Dia.	Complete Flanged Unit Number	Nominal Dimensions										Bolt Size	Housing Number	Bearing Number	Basic Load Ratings (lbs)	
		a	e	g	l	s	b	z	L	Di	n				Dynamic C	Static Co
20 3/4	UELFLU204D1 UELFLU204-012D1	113 4 7/16	90 3 35/64	15 19/32	29.5 1 5/32	11.5 1 5/32	61 2 13/32	45.6 1 51/64	43.7 1.720	33.3 1.31	17.1 .673	M10 5/16	FLU204D1 FLU204D1	UEL204D1 UEL204-012D1	2,890	1,500
25 1 3/16 7/8 1 5/16 1	UELFLU205D1 UELFLU205-013D1 UELFLU205-014D1 UELFLU205-015D1 UELFLU205-100D1	125 4 29/32	99 3 57/64	15 19/32	30 1 3/16	11.5 29/64	70 2 3/4	45.9 1 13/16	44.4 1.748	38.1 1.50	17.5 .689	M10 3/8	FLU205D1 FLU205D1 FLU205D1 FLU205D1	UEL205D1 UEL205-013D1 UEL205-014D1 UEL205-015D1 UEL205-100D1	3,150	1,770
30 1 1/16 1 1/8 1 3/16 1 1/4	UELFLU206D1 UELFLU206-101D1 UELFLU206-102D1 UELFLU206-103D1 UELFLU206-104D1	142 5 19/32	116.5 4 19/32	16 5/8	33 1 5/16	11.5 29/64	83 3 9/32	50.1 1 31/32	48.4 1.906	44.5 1.75	18.3 .720	M10 3/8	FLU206D1 FLU206D1 FLU206D1 FLU206D1	UEL206D1 UEL206-101D1 UEL206-102D1 UEL206-103D1 UEL206-104D1	4,400	2,540
35 1 1/4 1 5/16 1 3/8 1 7/16	UELFLU207D1 UELFLU207-104D1 UELFLU207-105D1 UELFLU207-106D1 UELFLU207-107D1	156 6 5/32	130 5 1/8	17 21/32	36 1 13/32	14 35/64	96 3 29/32	53.3 2 3/32	51.1 2.012	55.6 2.19	18.8 .740	M12 7/16	FLU207D1 FLU207D1 FLU207D1 FLU207D1	UEL207D1 UEL207-104D1 UEL207-105D1 UEL207-106D1 UEL207-107D1	5,750	3,440
40 1 1/2 1 5/16	UELFLU208D1 UELFLU208-108D1 UELFLU208-109D1	172 6 25/32	143.5 5 21/32	17 21/32	39 1 17/32	14 35/64	105 4 1/8	58.9 2 5/16	56.3 2.217	60.2 2.37	21.4 .843	M12 7/16	FLU208D1 FLU208D1 FLU208D1	UEL208D1 UEL208-108D1 UEL208-109D1	6,550	4,000
45 1 5/8 1 11/16 1 3/4	UELFLU209D1 UELFLU209-110D1 UELFLU209-111D1 UELFLU209-112D1	180 7 3/32	148.5 5 27/32	18 23/32	40 1 9/16	16 5/8	111 4 3/8	58.9 2 5/16	56.3 2.217	63.5 2.50	21.4 .843	M14 1/2	FLU209D1 FLU209D1 FLU209D1 FLU209D1	UEL209D1 UEL209-110D1 UEL209-111D1 UEL209-112D1	7,350	4,590
50 1 13/16 1 7/8 1 15/16 2	UELFLU210D1 UELFLU210-113D1 UELFLU210-114D1 UELFLU210-115D1 UELFLU210-200D1	190 7 15/32	157 6 3/16	20 25/32	46 1 13/16	18 45/64	116 4 9/16	66.1 2 39/64	62.7 2.469	69.9 2.75	24.6 .969	M16 1/2	FLU210D1 FLU210D1 FLU210D1 FLU210D1	UEL210D1 UEL210-113D1 UEL210-114D1 UEL210-115D1 UEL210-200D1	7,900	5,220
55 2 2 1/16 2 1/8 2 3/16	UELFLU211D1 UELFLU211-200D1 UELFLU211-201D1 UELFLU211-202D1 UELFLU211-203D1	217 8 17/32	184 7 1/4	21 13/16	49 1 15/16	18 45/64	134 5 9/32	74.6 2 15/16	71.4 2.811	76.2 3.00	27.8 1.094	M16 9/16	FLU211D1 FLU211D1 FLU211D1 FLU211D1	UEL211D1 UEL211-200D1 UEL211-201D1 UEL211-202D1 UEL211-203D1	9,750	6,570
60 2 1/4 2 3/8 2 7/16	UELFLU212D1 UELFLU212-204D1 UELFLU212-206D1 UELFLU212-207D1	235 9 1/4	202 7 61/64	21 13/16	53 2 3/32	18 45/64	138 5 7/16	80.8 3 3/16	77.8 3.063	84.1 3.31	31 1.220	M16 9/16	FLU212D1 FLU212D1 FLU212D1 FLU212D1	UEL212D1 UEL212-204D1 UEL212-206D1 UEL212-207D1	11,800	8,100
65 2 1/2	UELFLU213D1 UELFLU213-208D1	248 9 3/4	210 8 17/64	22 7/8	59 2 5/16	20.5 13/16	152 5 31/32	89.55 3 17/32	85.7 3.374	97.0 3.82	34.15 1.344	M18 5/8	FLU213D1 FLU213D1	UEL213D1 UEL213-208D1	12,900	9,000
70 2 11/16 2 3/4	UELFLU214D1 UELFLU214-211D1 UELFLU214-212D1	257 10 1/8	216 8 1/2	22 7/8	62 2 7/16	20.5 13/16	159 6 1/4	89.55 3 17/32	85.7 3.374	97.0 3.82	34.15 1.344	M18 5/8	FLU214D1 FLU214D1 FLU214D1	UEL214D1 UEL214-211D1 UEL214-212D1	14,000	9,900
75 2 15/16 3	UELFLU215D1 UELFLU215-215D1 UELFLU215-300D1	266 10 15/32	225 8 55/64	22 7/8	65 2 9/16	20.5 13/16	165 6 1/2	95.7 3 49/64	92 3.622	102 4.02	37.3 1.469	M18 5/8	FLU215D1 FLU215D1 FLU215D1	UEL215D1 UEL215-215D1 UEL215-300D1	14,900	11,130

NTN
SERIES
AELFL2
ECCENTRIC
LOCKING
COLLAR
RELUBE
TYPE

Units: Millimeters
 INCHES

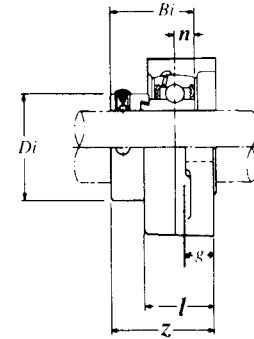
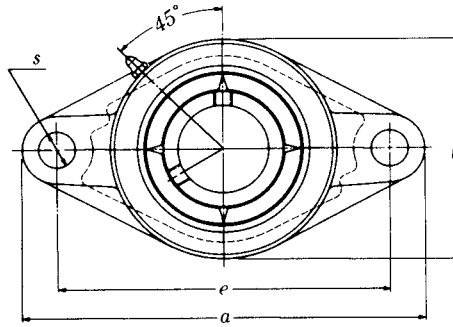

Flanged Units - Cast Housing (2 Bolt)

Shaft Dia.	Complete Pillow Block Number	Nominal Dimensions									Bolt Size	Housing Number	Bearing Number	Basic Load Ratings (lbs)	
		a	e	g	l	s	z	Bi	Di	n				Dynamic C	Static Co
20	AELFL204D1	113	90	11	25.5	12	38.5	31	33.3	7.5	M10	FL204D1	AEL204D1	2,890	1,500
3/4	AELFL204-012D1	4 7/16	3 17/32	7/16	1	15/32	1 33/64	1.219	1.31	0.295	3/8	FL204D1	AEL204-012D1		
25	AELFL205D1	130	99	13	27	16	40	31	38.1	7.5	M14	FL205D1	AEL205D1	3,150	1,770
13/16	AELFL205-013D1	5 1/8	3 29/32	1/2	1 1/16	5/8	1 9/16	1.219	1.50	0.295	1/2	FL205D1	AEL205-013D1		
7/8	AELFL205-014D1											FL205D1	AEL205-014D1		
15/16	AELFL205-015D1											FL205D1	AEL205-015D1		
1	AELFL205-100D1											FL205D1	AEL205-100D1		
30	AELFL206D1	148	117	13	31	16	44.8	35.7	44.5	9	M14	FL206D1	AEL206D1	4,400	2,540
1 1/16	AELFL206-101D1	5 19/16	4 19/32	1/2	1 7/32	5/8	1 49/64	1.406	1.75	0.354	1/2	FL206D1	AEL206-101D1		
1 1/8	AELFL206-102D1											FL206D1	AEL206-102D1		
1 3/16	AELFL206-103D1											FL206D1	AEL206-103D1		
1 1/4	AELFL206-104D1											FL206D1	AEL206-104D1		
												FL206D1	AEL206-104D1		
35	AELFL207D1	161	130	15	34	16	48.4	38.9	55.6	9.5	M14	FL207D1	AEL207D1	5,750	3,440
1 1/4	AELFL207-104D1	6 11/16	5 1/8	19/32	1 11/32	5/8	1 29/32	1.531	2.19	0.374	1/2	FL207D1	AEL207-104D1		
1 5/16	AELFL207-105D1											FL207D1	AEL207-105D1		
1 3/8	AELFL207-106D1											FL207D1	AEL207-106D1		
1 7/16	AELFL207-107D1											FL207D1	AEL207-107D1		
												FL207D1	AEL207-107D1		
40	AELFL208D1	175	144	15	36	16	53.6	43.7	60.2	11	M14	FL208D1	AEL208D1	6,550	4,000
1 1/2	AELFL208-108D1	6 7/8	5 21/32	19/32	1 13/32	5/8	2 7/64	1.719	2.37	0.433	1/2	FL208D1	AEL208-108D1		
1 9/16	AELFL208-109D1											FL208D1	AEL208-109D1		
												FL208D1	AEL208-109D1		
45	AELFL209D1	188	148	16	38	19	54.8	43.7	63.5	11	M16	FL209D1	AEL209D1	7,350	4,590
1 5/8	AELFL209-110D1	7 13/32	5 13/16	5/8	1 1/2	3/4	2 5/32	1.719	2.50	0.433	5/8	FL209D1	AEL209-110D1		
1 11/16	AELFL209-111D1											FL209D1	AEL209-111D1		
1 3/4	AELFL209-112D1											FL209D1	AEL209-112D1		
												FL209D1	AEL209-112D1		
50	AELFL210D1	197	157	16	40	19	54.8	43.7	69.90	11	M16	FL210D1	AEL210D1	7,900	5,220
1 13/16	AELFL210-113D1	7 3/4	6 3/16	5/8	1 9/16	3/4	2 5/32	1.719	2.75	0.433	5/8	FL210D1	AEL210-113D1		
1 7/8	AELFL210-114D1											FL210D1	AEL210-114D1		
1 15/16	AELFL210-115D1											FL210D1	AEL210-115D1		
												FL210D1	AEL210-115D1		

Units: Millimeters
INCHES

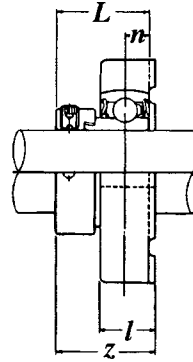
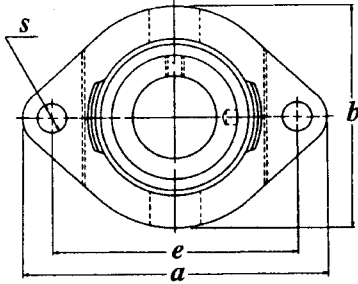

FLANGED UNITS - CAST HOUSING (TWO BOLT)

Shaft Diameter	Complete Flanged Unit Number D ₁	Nominal Dimensions								Bolt Size	Housing Number	Bearing Number	Basic Load Ratings (lbs)	
		a	e	s	b	l	z	L	n				Dynamic C	Static C ₀
20 3/4	JELFL204D1W3 JELFL204-012D1W3	113 4 7/16	90 3 35/64	12 15/32	60 2 3/8	25.5 1	38.5 1 33/64	31.0 1.220	7.5 .295	M10 5/16	FL204D1 FL204D1	JEL204D1W3 JEL204-012D1W3	2,890	1,500
25 13/16 7/8 15/16 1	JELFL205D1W3 JELFL205-013D1W3 JELFL205-014D1W3 JELFL205-015D1W3 JELFL205-100D1W3	130 5 1/8	99 3 57/64	16 5/8	68 2 11/16	27 1 1/16	39.5 1 9/16	31.0 1.220	7.5 .295	M14 1/2	FL205D1 FL205D1	JEL205D1W3 JEL205-013D1W3 JEL205-014D1W3 JEL205-015D1W3 JEL205-100D1W3	3,150	1,770
30 1 1/16 1 1/8 1 3/16 1 1/4	JELFL206D1W3 JELFL206-101D1W3 JELFL206-102D1W3 JELFL206-103D1W3 JELFL206-104D1W3	148 5 13/16	117 4 39/64	16 5/8	80 3 5/12	31 1 7/32	44.7 1 49/64	35.7 1.406	9 .354	M14 1/2	FL206D1 FL206D1	JEL206D1W3 JEL206-101D1W3 JEL206-102D1W3 JEL206-103D1W3 JEL206-104D1W3	4,400	2,540
35 1 1/4 1 5/16 1 3/8 1 7/16	JELFL207D1W3 JELFL207-104D1W3 JELFL207-105D1W3 JELFL207-106D1W3 JELFL207-107D1W3	161 6 11/32	130 5 1/8	16 5/8	90 3 17/32	34 1 11/32	48.4 1 29/32	38.9 1.531	9.5 .374	M14 1/2	FL207D1 FL207D1	JEL207D1W3 JEL207-104D1W3 JEL207-105D1W3 JEL207-106D1W3 JEL207-107D1W3	5,750	3,440
40 1 1/2 1 9/16	JELFL208D1W3 JELFL208-108D1W3 JELFL208-109D1W3	175 6 7/8	144 5 43/64	16 5/8	100 3 15/16	36 1 11/32	53.7 2 7/16	43.7 1.720	11 .433	M14 1/2	FL208D1 FL208D1	JEL208D1W3 JEL208-108D1W3 JEL208-109D1W3	6,550	4,000
45 1 5/8 1 11/16 1 3/4	JELFL209D1W3 JELFL209-110D1W3 JELFL209-111D1W3 JELFL209-112D1W3	188 7 13/32	148 5 53/64	19 3/4	108 4 1/4	38 1 1/2	54.7 2 5/32	43.7 1.720	11 .433	M16 5/8	FL209D1 FL209D1	JEL209D1W3 JEL209-110D1W3 JEL209-111D1W3 JEL209-112D1W3	7,350	4,590
50 1 13/16 1 7/8 1 15/16 2	JELFL210D1W3 JELFL210-113D1W3 JELFL210-114D1W3 JELFL210-115D1W3 JELFL210-220D1W3	197 7 3/4	157 6 3/16	19 3/4	115 4 17/32	40 19/16	54.7 2 5/32	43.7 1.720	11 .433	M16 5/8	FL210D1 FL210D1	JEL210D1W3 JEL210-113D1W3 JEL210-114D1W3 JEL210-115D1W3 JEL210-220D1W3	7,900	5,220
55 2 2 1/16 2 1/8 2 3/16	JELFL211D1W3 JELFL211-200D1W3 JELFL211-201D1W3 JELFL211-202D1W3 JELFL211-203D1W3	224 8 13/16	184 7 61/64	19 3/4	130 5 1/8	43 1 11/16	61.4 2 27/64	48.4 1.906	12 .472	M16 5/8	FL211D1 FL211D1	JEL211D1W3 JEL211-200D1W3 JEL211-201D1W3 JEL211-202D1W3 JEL211-203D1W3	9,750	6,570
60 2 1/4 2 5/16 2 3/8	JELFL212D1W3 JELFL212-204D1W3 JELFL212-205D1W3 JELFL212-206D1W3	250 9 27/32	202 7 61/64	23 29/32	140 5 1/2	48 1 7/8	68.6 2 45/64	53.1 2.091	13.5 .531	M20 3/4	FL212D1 FL212D1	JEL212D1W3 JEL212-204D1W3 JEL212-205D1W3 JEL212-206D1W3	11,800	8,100



Units: Millimeters
INCHES

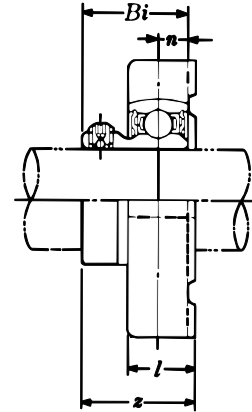
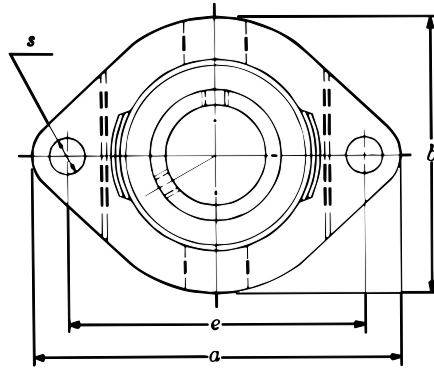

FLANGED UNITS - CAST HOUSING (TWO BOLT)

Shaft Dia.	Complete Flanged Unit Number	Nominal Dimensions									Bolt Size	Housing Number	Bearing Number	Basic Load Ratings (lbs)	
		a	e	l	s	b	z	Bi	n	Dynamic C				Static C _n	
12 ½	ASFD201 ASFD201-008	81 3 ¾	63 2 15/32	15 1 9/32	7 7/32	59 2 5/16	24.5 3 1/32	22 .866	6 .236	M6 ¼	FD201 FD201	AS201 AS201-008	2,160	1,040	
15 9/16 5/8	ASFD202 ASFD202-009 ASFD202-010	81 3 ¾	63 2 15/32	15 1 9/32	7 7/32	59 2 5/16	24.5 3 1/32	22 .866	6 .236	M6 ¼	FD201 FD201 FD201	AS202 AS202-009 AS202-010	2,160	1,040	
17 1 1/16	ASFD203 *ASFD203-011	81 3 ¾	63 2 15/32	15 1 9/32	7 7/32	59 2 5/16	24.5 3 1/32	22 .866	6 .236	M6 ¼	FD201 FD201	AS203 AS203-011	2,160	1,040	
20 ¾	ASFD204 ASFD204-012	90 3 17/32	71 2 25/32	17 2 1/32	10 25/64	67 2 5/8	27.5 1 5/64	25 .984	7 .276	M8 5/16	FD204 FD204	AS204 AS204-012	2,890	1,500	
25 1 3/16 7/8 1 5/16 1	ASFD205 ASFD205-013 ASFD205-014 ASFD205-015 ASFD205-100	95 3 ¾	76 3	17 2 1/32	10 25/64	71 2 25/32	29 1 9/64	27 1.063	7.5 .295	M8 5/16	FD205 FD205 FD205 FD205	AS205 AS205-013 AS205-014 AS205-015 AS205-100	3,150	1,770	
30 1 1/16 1 1/8 1 3/16 1 ¼	ASFD206 ASFD206-101 ASFD206-102 ASFD206-103 *ASFD206-104	113 4 7/16	90 3 17/32	21 1 3/16	12 15/32	84 3 5/16	33 1 19/64	29 1.142	8 .315	M10 3/8	FD206 FD206 FD206 FD206	AS206 AS206-101 AS206-102 AS206-103 AS206-104	4,400	2,540	
35 1 ¼ 1 5/16 1 3/8 1 7/16	ASFD207 ASFD207-104 ASFD207-105 ASFD207-106 *ASFD207-107	125 4 29/32	100 3 15/16	22 7/8	12 15/32	94 3 11/16	38 1 ½	34 1.339	8.5 .335	M10 3/8	FD207 FD207 FD207 FD207	AS207 AS207-104 AS207-105 AS207-106 AS207-107	5,750	3,440	

Remarks: 1) If relubricatable type is needed, please order with suffix "A-", "D1", ex. A-ASFD201D1

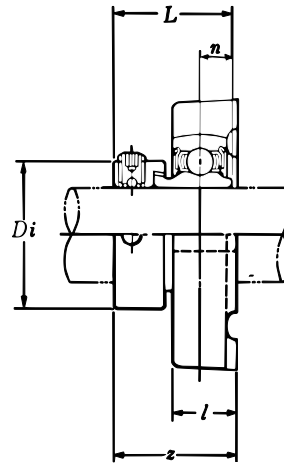
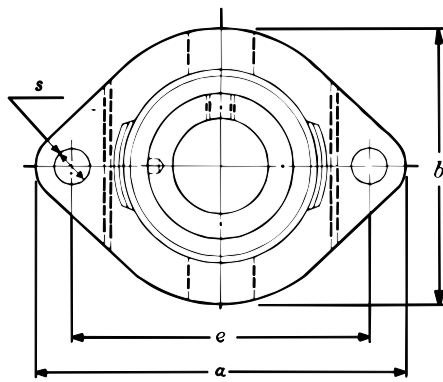

Units: Millimeters
INCHES



FLANGED UNITS - CAST HOUSING (TWO BOLT)

Shaft Dia.	Complete Flanged Unit Number	Nominal Dimensions								Bolt Size	Housing Number	Bearing Number	Basic Load Ratings (lbs)	
		a	e	s	l	b	Di	L	n				Dynamic C	Static Co
12 ½	AELFD201 AELFD201-008	81 3 ⅜	63 2 15/32	7 9/32	15 1 9/32	59 2 5/16	29 1.14	28.6 1.126	6.5 .256	M6 ¼	FD201 FD201	AEL201 AEL201-008	2,160	1,040
15 9/16 5/8	AELFD202 AELFD202-009 AELFD202-010	81 3 ⅜	63 2 15/32	7 9/32	15 1 9/32	59 2 5/16	29 1.14	28.6 1.126	6.5 .256	M6 ¼	FD201 FD201 FD201	AEL202 AEL202-009 AEL202-010	2,160	1,040
17 1 1/16	AELFD203 AELFD203-011	81 3 ⅜	63 2 15/32	7 9/32	15 1 9/32	59 2 5/16	29 1.14	28.6 1.126	6.5 .256	M6 ¼	FD201 FD201	AEL203 AEL203-011	2,160	1,040
20 ¾	AELFD204 AELFD204-012	90 3 17/32	71 2 25/32	10 25/64	17 2 1/32	67 2 5/8	33.3 1.31	31 1.220	7.5 .295	M8 5/16	FD204 FD204	AEL204 AEL204-012	2,890	1,500
25 13/16 7/8 15/16 1	AELFD205 AELFD205-013 AELFD205-014 AELFD205-015 AELFD205-100	95 3 ¾	76 3	10 25/64	17 2 1/32	71 2 25/32	38.1 1.50	31 1.220	7.5 .295	M8 5/16	FD205 FD205 FD205 FD205	AEL205 AEL205-013 AEL205-014 AEL205-015 AEL205-100	3,150	1,770
30 1 1/16 1 1/8 1 3/16 1 ¼	AELFD206 AELFD206-101 AELFD206-102 AELFD206-103 AELFD206-104	113 4 7/16	90 3 17/32	12 15/32	21 1 3/16	84 3 5/16	44.5 1.75	35.7 1.406	9 .354	M10 3/8	FD206 FD206 FD206 FD206	AEL206 AEL206-101 AEL206-102 AEL206-103 AEL206-104	4,400	2,540
35 1 ¼ 1 5/16 1 3/8 1 7/16	AELFD207 AELFD207-104 AELFD207-105 AELFD207-106 AELFD207-107	125 4 29/32	100 3 15/16	12 15/32	22 7/8	94 3 11/16	55.6 2.19	38.9 1.531	9.5 .374	M10 3/8	FD207 FD207 FD207 FD207	AEL207 AEL207-104 AEL207-105 AEL207-106 AEL207-107	5,750	3,440

Remarks: 1) If relubricatable type is needed, please order with suffix "A-", "D1", ex. A-AELFD201D1

NTN
SERIES
JELFD2
ECENTRIC
LOCKING
COLLAR
TYPE

Units: Millimeters
 INCHES

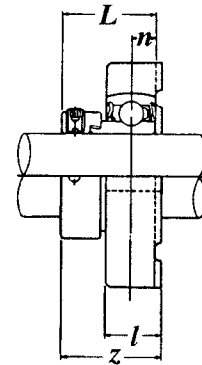
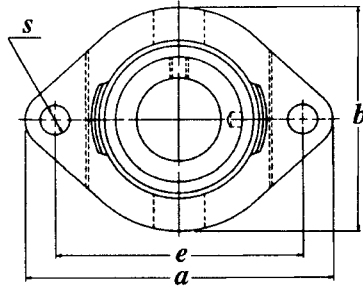

FLANGED UNITS - CAST HOUSING (TWO BOLT)

Shaft Dia.	Complete Flanged Unit Number	Nominal Dimensions									Bolt Size	Housing Number	Bearing Number	Basic Load Ratings (lbs)	
		<i>a</i>	<i>e</i>	<i>s</i>	<i>b</i>	<i>l</i>	<i>z</i>	<i>Di</i>	<i>L</i>	<i>n</i>				Dynamic <i>C</i>	Static <i>C₀</i>
12 1/2	JELFD201 JELFD201-008	81 3 3/16	63 2 15/32	7 9/32	59 2 5/16	15 19/32	30.6 1 13/64	29 1.14	28.6 1.126	6.5 .256	M6 1/4	FD201 FD201	JEL201 JEL201-008	2,160	1,030
15 9/16 5/8	JELFD202 JELFD202-009 JELFD202-010	81 3 3/16	63 2 15/32	7 9/32	59 2 5/16	15 19/32	30.6 1 13/64	29 1.14	28.6 1.126	6.5 .256	M6 1/4	FD201 FD201 FD201	JEL202 JEL202-009 JEL202-010	2,160	1,030
17 11/16	JELFD203 JELFD203-011	81 3 3/16	63 2 15/32	7 9/32	59 2 5/16	15 19/32	30.6 1 13/64	29 1.14	28.6 1.126	6.5 .256	M6 1/4	FD201 FD201	JEL203 JEL203-011	2,160	1,030
20 3/4	JELFD204 JELFD204-012	90 3 17/32	71 2 25/32	10 25/64	67 2 5/8	17 21/32	33 1 19/64	33.3 1.31	31 1.220	7.5 .295	M8 5/16	FD204 FD204	JEL204 JEL204-012	2,890	1,500
25 13/16 7/8 15/16 1	JELFD205 JELFD205-013 JELFD205-014 JELFD205-015 JELFD205-100	95 3 3/4	76 3	10 25/64	71 2 25/32	17 21/32	33 1 19/64	38.1 1.50	31 1.220	7.5 .295	M8 5/16	FD205 FD205 FD205 FD205	JEL205 JEL205-013 JEL205-014 JEL205-015 JEL205-100	3,150	1,770
30 1 1/16 1 1/8 1 3/16 1 1/4	JELFD206 JELFD206-101 JELFD206-102 JELFD206-103 JELFD206-104	113 4 7/16	90 3 17/32	12 15/32	84 3 5/16	21 13/16	38.7 1 17/32	44.5 1.75	35.7 1.406	9 .354	M10 3/8	FD206 FD206 FD206 FD206	JEL206 JEL206-101 JEL206-102 JEL206-103 JEL206-104	4,400	2,540
35 1 1/4 1 5/16 1 3/8 1 7/16	JELFD207 JELFD207-104 JELFD207-105 JELFD207-106 JELFD207-107	125 4 29/32	100 3 15/16	12 15/32	94 3 11/16	22 7/8	41.9 1 21/32	55.6 2.19	38.9 1.531	9.5 .374	M10 3/8	FD207 FD207 FD207 FD207	JEL207 JEL207-104 JEL207-105 JEL207-106 JEL207-107	5,750	3,450

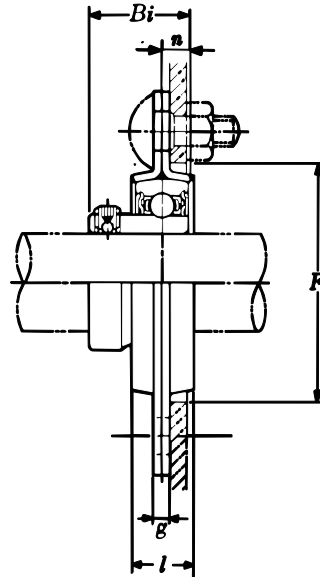
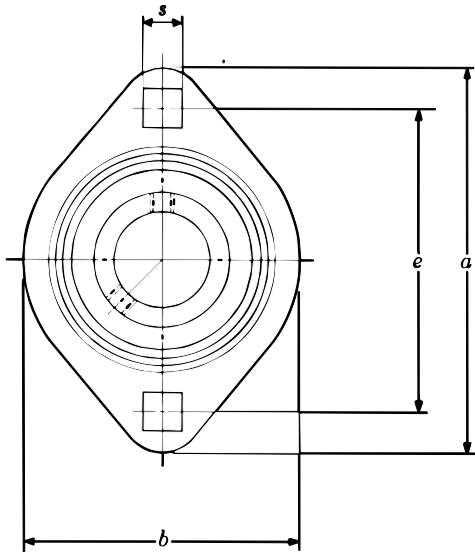

Units: Millimeters
INCHES



FLANGED UNITS - PRESSED STEEL HOUSING (TWO BOLT)

Shaft Dia.	Complete Flanged Unit Number	Nominal Dimensions								Bolt Size	Housing Number	Bearing Number	Basic Load Ratings (lbs)		Max. Radial Load (lbs)
		a	e	g	s	l	Bi	n	(min) F				Dynamic C	Static C_0	
12 ½	ASPFL201 ASPFL201-008	81 3 ¾	63 2 15/32	4 .157	7 9/32	14 9/16	22 .866	6 .236	49 1 15/16	M6 ¼	PFL203 PFL203	AS201 AS201-008	2,160	1,040	600
15 9/16 5/8	ASPFL202 ASPFL202-009 ASPFL202-010	81 3 ¾	63 2 15/32	4 .157	7 9/32	14 9/16	22 .866	6 .236	49 1 15/16	M6 ¼	PFL203 PFL203 PFL203	AS202 AS202-009 AS202-010	2,160	1,040	600
17 1 1/16	ASPFL203 ASPFL203-011	81 3 ¾	63 2 15/32	4 .157	7 9/32	14 9/16	22 .866	6 .236	49 1 15/16	M6 ¼	PFL203 PFL203	AS203 AS206-011	2,160	1,040	600
20 ¾	ASPFL204 ASPFL204-012	90 3 17/32	71 2 25/32	4 .157	9 23/64	16 5/8	25 .984	7 .276	56 2 7/32	M8 5/16	PFL204 PFL204	AS204 AS204-012	2,890	1,500	660
25 1 3/16 7/8 15/16 1	ASPFL205 ASPFL205-013 ASPFL205-014 ASPFL205-015 ASPFL205-100	95 3 ¾	76 3	4 .157	9 23/64	18 23/32	27 1.063	7.5 .295	60 2 ¾	M8 5/16	PFL205 PFL205 PFL205 PFL205	AS205 AS205-013 AS205-014 AS205-015 AS205-100	3,150	1,770	880
30 1 1/16 1 1/8 1 3/16	ASPFL206 ASPFL206-101 ASPFL206-102 ASPFL206-103 ASPFL206-104	113 4 7/16	90 3 17/32	5.2 .205	11 7/16	18 23/32	29 1.142	8 .315	71 2 25/32	M10 ¾	PFL206 PFL206 PFL206 PFL206 PFL206	AS206 AS206-101 AS206-102 AS206-103 AS206-104	4,400	2,540	1,100
35 1 ¼ 1 5/16 1 ¾ 1 7/16	ASPFL207 ASPFL207-104 ASPFL207-105 ASPFL207-106 ASPFL207-107	122 4 13/16	100 3 15/16	5.2 .205	11 7/16	20 25/32	34 1.339	8.5 .335	81 3 3/16	M10 ¾	PFL207 PFL207 PFL207 PFL207 PFL207	AS207 AS207-104 AS207-105 AS207-106 AS207-107	5,750	3,440	1,300

Axial load should be less than 1/3 of radial load.

NTN
SERIES
AELPFL2
ECCENTRIC
LOCKING
COLLAR
TYPE

Units: **Millimeters**
INCHES

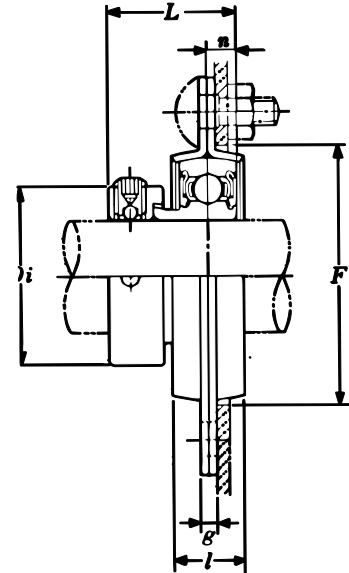
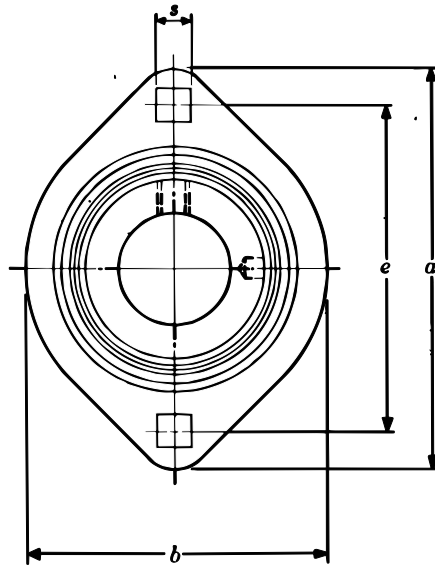

FLANGED UNITS - PRESSED STEEL HOUSING (TWO BOLT)

Shaft Dia.	Complete Flanged Unit Number	Nominal Dimensions										Bolt Size	Housing Number	Bearing Number	Basic Load Ratings (lbs)		Max. Radial Load (lbs)
		<i>a</i>	<i>e</i>	<i>g</i>	<i>s</i>	<i>l</i>	<i>b</i>	<i>Di</i>	<i>L</i>	<i>n</i>	(<i>min</i>) <i>F</i>				<i>C</i>	<i>C₀</i>	
12 1/2	AELPFL201 AELPFL201-008W3	81 3 3/16	63 2 15/32	4 .157	7 9/32	14 9/16	59 2 5/16	29 1.14	28.6 1.126	6.5 .256	49 1 15/16	M6 1/4	PFL203 PFL203	AEL201 AEL201-088W3	2,160	1,040	600
15 9/16 5/8	AELPFL202 AELPFL202-009W3 AELPFL202-010W3	81 3 3/16	63 2 15/32	4 .157	7 9/32	14 9/16	59 2 5/16	29 1.14	28.6 1.126	6.5 .256	49 1 15/16	M6 1/4	PFL203 PFL203 PFL203	AEL202 AEL202-009W3 AEL202-010W3	2,160	1,040	600
17 11/16	AELPFL203 AELPFL203-011W3	81 3 3/16	63 2 15/32	4 .157	7 9/32	14 9/16	59 2 5/16	29 1.14	28.6 1.126	6.5 .256	49 1 15/16	M6 1/4	PFL203 PFL203	AEL203 AEL203-011W3	2,160	1,040	600
20 3/4	AELPFL204 AELPFL204-012W3	90 3 17/32	71 2 29/32	4 .157	9 23/64	16 5/8	67 2 5/8	33.3 1.31	31 1.220	7.5 .295	56 2 7/32	M8 5/16	PFL204 PFL204	AEL204 AEL204-012W3	2,890	1,500	660
25 1 3/16 7/8 1 1/4	AELPFL205 AELPFL205-013W3 AELPFL205-014W3 AELPFL205-015W3 AELPFL205-100W3	95 3 3/4	76 3	4 .157	9 23/64	18 23/32	71 2 25/32	38.1 1.50	31 1.220	7.5 .295	60 2 3/8	M8 5/16	PFL205 PFL205 PFL205 PFL205 PFL205	AEL205 AEL205-013W3 AEL205-014W3 AEL205-015W3 AEL205-100W3	3,150	1,770	880
30 1 1/16 1 1/8 1 3/16 1 1/4	AELPFL206 AELPFL206-101W3 AELPFL206-102W3 AELPFL206-103W3 AELPFL206-104W3	113 4 7/16	90 3 17/32	5.2 .205	11 7/16	18 23/32	84 3 5/16	44.5 1.75	35.7 1.406	9 .354	71 2 25/32	M10 3/8	PFL206 PFL206 PFL206 PFL206 PFL206	AEL206 AEL206-101W3 AEL206-102W3 AEL206-103W3 AEL206-104W3	4,400	2,540	1,100
35 1 1/4 1 5/16 1 3/8 1 7/16	AELPFL207 AELPFL207-104W3 AELPFL207-105W3 AELPFL207-106W3 AELPFL207-107W3	122 4 13/16	100 3 15/16	5.2 .205	11 7/16	20 25/32	94 3 11/16	55.6 2.19	38.9 1.531	9.5 .374	81 3 3/16	M10 3/8	PFL207 PFL207 PFL207 PFL207 PFL207	AEL207 AEL207-104W3 AEL207-105W3 AEL207-106W3 AEL207-107W3	5,750	3,440	1,300

Axial load should be less than 1/3 of radial load.

Units: Millimeters
INCHES

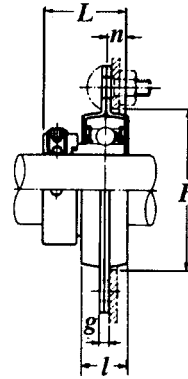
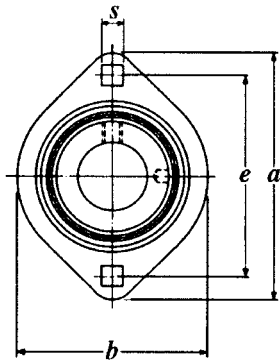

FLANGED UNITS - PRESSED STEEL HOUSING (TWO BOLT)

Shaft Dia.	Complete Flanged Unit Number	Nominal Dimensions										Bolt Size	Housing Number	Bearing Number	Basic Load Ratings (lbs)		Max. Radial Load (lbs)
		a	e	g	s	l	b	Di	L	n	(min) F				Dynamic C	Static C ₀	
12 1/2	JELPFL201 JELPFL201-008	81 3 3/16	63 2 15/32	4 .157	7 9/32	14 9/16	59 2 5/16	29 1.14	28.6 1.126	6.5 .256	49 1 15/16	M6 1/4	PFL203 PFL203	JEL201 JEL201-088	2,160	1,030	600
15 9/16 5/8	JELPFL202 JELPFL202-009 JELPFL202-010	81 3 3/16	63 2 15/32	4 .157	7 9/32	14 9/16	59 2 5/16	29 1.14	28.6 1.126	6.5 .256	49 1 15/16	M6 1/4	PFL203 PFL203 PFL203	JEL202 JEL202-009 JEL202-010	2,160	1,030	600
17 1 1/16	JELPFL203 JELPFL203-011	81 3 3/16	63 2 15/32	4 .157	7 9/32	14 9/16	59 2 5/16	29 1.14	28.6 1.126	6.5 .256	49 1 15/16	M6 1/4	PFL203 PFL203	JEL203 JEL203-011	2,160	1,030	600
20 3/4	JELPFL204 JELPFL204-012	90 3 17/32	71 2 25/32	4 .157	9 23/64	16 5/8	67 2 5/8	33.3 1.31	31 1.220	7.5 .295	56 2 7/32	M8 5/16	PFL204 PFL204	JEL204 JEL204-012	2,890	1,500	660
25 1 3/16 7/8 15/16 1	JELPFL205 JELPFL205-013 JELPFL205-014 JELPFL205-015 JELPFL205-100	95 3 3/4	76 3	4 .157	9 23/64	18 23/32	71 2 29/32	38.1 1.50	31 1.220	7.5 .295	60 2 3/8	M8 5/16	PFL205 PFL205 PFL205 PFL205	JEL205 JEL205-013 JEL205-014 JEL205-015 JEL205-100	3,150	1,770	880
30 1 1/16 1 1/8 1 3/16 1 1/4	JELPFL206 JELPFL206-101 JELPFL206-102 JELPFL206-103 JELPFL206-104	113 4 7/16	90 3 17/32	5.2 .205	11 7/16	18 23/32	84 3 5/16	44.5 1.75	35.7 1.406	9 .354	71 2 25/32	M10 3/8	PFL206 PFL206 PFL206 PFL206	JEL206 JEL206-101 JEL206-102 JEL206-103 JEL206-104	4,400	2,540	1,100
35 1 1/4 1 9/16 1 3/8 1 7/16	JELPFL207 JELPFL207-104 JELPFL207-105 JELPFL207-106 JELPFL207-107	122 4 13/16	100 3 15/16	5.2 .205	11 7/16	20 25/32	94 3 11/16	55.6 2.19	38.9 1.531	9.5 .374	81 3 3/16	M10 3/8	PFL207 PFL207 PFL207 PFL207	JEL207 JEL207-104 JEL207-105 JEL207-106 JEL207-107	5,750	3,450	1,300

Axial load should be less than 1/3 of radial load.



Units: Millimeters
INCHES

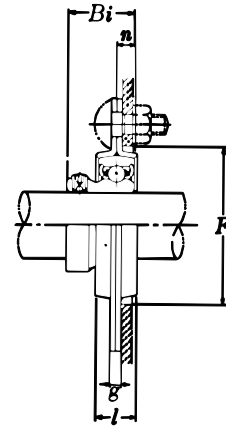
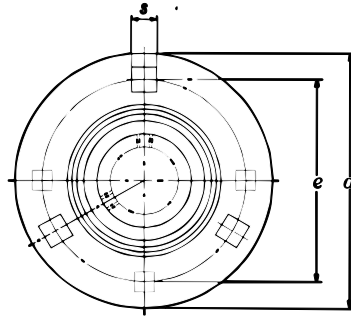

FLANGED UNITS - PRESSED STEEL HOUSING (THREE BOLT)

Shaft Dia.	Complete Flanged Unit Number	Nominal Dimensions								Bolt Size	Housing Number	Bearing Number	Basic Load Ratings (lbs)		Max. Radial Load (lbs)
		a	e	g	s	l	Bi	n	(min) F				Dynamic C	Static C ₀	
12 ½	ASPF201 ASPF201-008	81 3 ¾	63 2 15/32	4 .157	7 9/32	14 9/16	22 .866	6 .236	49 1 15/16	M6 ¼	PF203 PF203	AS201 AS201-008	2,160	1,040	600
15 9/16 5/8	ASPF202 ASPF202-009 ASPF202-010	81 3 ¾	63 2 15/32	4 .157	7 9/32	14 9/16	22 .866	6 .236	49 1 15/16	M6 ¼	PF203 PF203 PF203	AS202 AS202-009 AS202-010	2,160	1,040	600
17 1 1/16	ASPF203 ASPF203-011	81 3 ¾	63 2 15/32	4 .157	7 9/32	14 9/16	22 .866	6 .236	49 1 15/16	M6 ¼	PF203 PF203	AS203 AS203-011	2,160	1,040	600
20 ¾	ASPF204 ASPF204-012	90 3 17/32	71 2 29/32	4 .157	9 23/64	16 5/8	25 .984	7 .276	56 2 7/32	M8 5/16	PF204 PF204	AS204 AS204-012	2,890	1,500	660
25 1 3/16 7/8 15/16 1	ASPF205 ASPF205-013 ASPF205-014 ASPF205-015 ASPF205-100	95 3 ¾	76 3	4 .157	9 23/64	18 23/32	27 1.063	7.5 .295	60 2 ¾	M8 5/16	PF205 PF205 PF205 PF205	AS205 AS205-013 AS205-014 AS205-015 AS205-100	3,150	1,770	880
30 1 1/16 1 1/8 1 3/16 1 ¼	ASPF206 ASPF206-101 ASPF206-102 ASPF206-103 ASPF206-104	113 4 7/16	90 3 17/32	5.2 .205	11 7/16	18 23/32	29 1.142	8 .315	71 2 25/32	M10 ¾	PF206 PF206 PF206 PF206	AS206 AS206-101 AS206-102 AS206-103 AS206-104	4,400	2,540	1,100
35 1 ¼ 1 5/16 1 ¾ 1 7/16	ASPF207 ASPF207-104 ASPF207-105 ASPF207-106 ASPF207-107	122 4 13/16	100 3 15/16	5.2 .205	11 7/16	20 25/32	34 1.339	8.5 .335	81 3 3/16	M10 ¾	PF207 PF207 PF207 PF207	AS207 AS207-104 AS207-105 AS207-106 AS207-107	5,750	3,440	1,300
40 1 ½ 1 9/16	ASPF208 ASPF208-108 ASPF208-109	148 5 13/16	119 4 11/16	6.8 .268	14 9/16	21 13/16	38 1.496	9 .354	91 3 9/16	M12 ½	PF208 PF208 PF208	AS208 AS208-108 AS208-109	6,550	4,000	1,500

Axial load should be less than 1/3 of radial load.

Units: Millimeters
INCHES

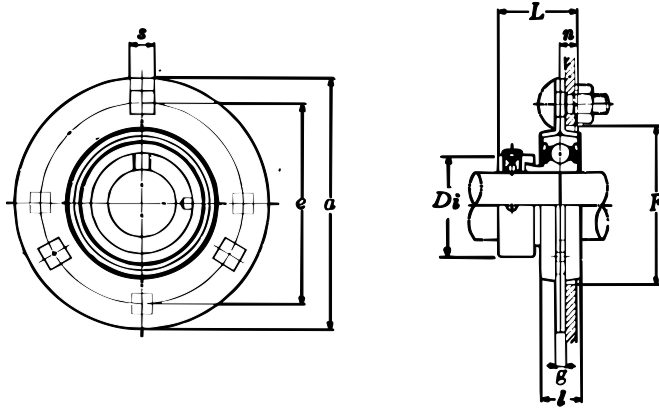

FLANGED UNITS - PRESSED STEEL HOUSING (THREE BOLT)

Shaft Dia.	Complete Flanged Unit Number	Nominal Dimensions								Bolt Size	Housing Number	Bearing Number	Basic Load Ratings (lbs)		Max. Radial Load (lbs)
		a	e	g	s	l	Bi	n	(min) F				Dynamic C	Static C ₀	
12 ½	AELPF201 AELPF201-008W3	81 3 ⅜	63 2 15/32	4 .157	7 9/32	14 9/16	29 1.14	6.5 .256	49 1 15/16	M6 ¼	PF203	AEL201 AEL201-008W3	2160	1040	600
15 9/16 5/8	AELPF202 AELPF202-009W3 AELPF202-010W3	81 3 ⅜	63 2 15/32	4 .157	7 9/32	14 9/16	29 1.14	6.5 .256	49 1 15/16	M6 ¼	PF203 PF203 PF203	AEL202 AEL202-009W3 AEL202-010W3	2160	1040	600
17 1 1/16	AELPF203 AELPF203-011W3	81 3 ⅜	63 2 15/32	4 .157	7 9/32	14 9/16	29 1.14	6.5 .256	49 1 15/16	M6 ¼	PF203 PF203	AEL203 AEL203-011W3	2160	1040	600
20 ¾	AELPF204 AELPF204-012W3	90 3 17/32	71 2 25/32	4 .157	9 23/64	16 5/8	33.3 1.31	7.5 .295	56 2 7/32	M8 5/16	PF204 PF204	AEL204 AEL204-012W3	2890	1500	660
25 1 3/16 7/8 15/16 1	AELPF205 AELPF205-013W3 AELPF205-014W3 AELPF205-015W3 AELPF205-100W3	95 3 ¾	76 3	4 .157	9 23/64	18 23/32	38.1 1.50	7.5 .295	60 2 3/8	M8 5/16	PF205 PF205 PF205 PF205	AEL205 AEL205-013W3 AEL205-014W3 AEL205-015W3 AEL205-100W3	3150	1770	880
30 1 1/16 1 1/8 1 3/16 1 ¼	AELPF206 AELPF206-101W3 AELPF206-102W3 AELPF206-103W3 AELPF206-104W3	113 4 7/16	90 3 17/32	5.2 .205	11 7/16	18 23/32	44.5 1.75	9 .354	71 2 25/32	M10 3/8	PF206 PF206 PF206 PF206	AEL206 AEL206-101W3 AEL206-102W3 AEL206-103W3 AEL206-104W3	4400	2540	1100
35 1 ¼ 1 5/16 1 3/8 1 7/16	AELPF207 AELPF207-104W3 AELPF207-105W3 AELPF207-106W3 AELPF207-107W3	122 4 13/16	100 3 15/16	5.2 .205	11 7/16	20 25/32	55.6 2.19	9.5 .374	81 3 3/16	M10 3/8	PF207 PF207 PF207 PF207	AEL207 AEL207-104W3 AEL207-105W3 AEL207-106W3 AEL207-107W3	5750	3440	1300
40 1 ½ 1 9/16	AELPF208 AELPF208-108W3 AELPF208-109W3	148 5 13/16	119 4 11/16	6.8 .268	14 9/16	21 1 1/16	60 2.36	11 .433	91 3 3/16	M12 ½	PF208 PF208 PF208	AEL208 AEL208-108W3 AEL208-109W3	6550	4000	1500

Axial load should be less than 1/3 of radial load.
AELPF208 has four bolt holes.

NTN
SERIES
JELPF2
ECCENTRIC
LOCKING
COLLAR
TYPE

Units: Millimeters
 INCHES

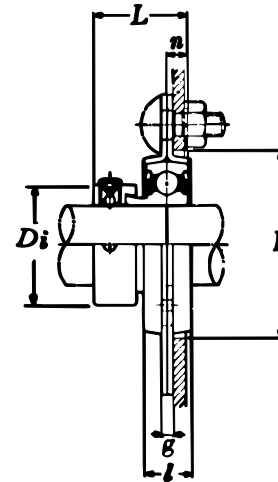
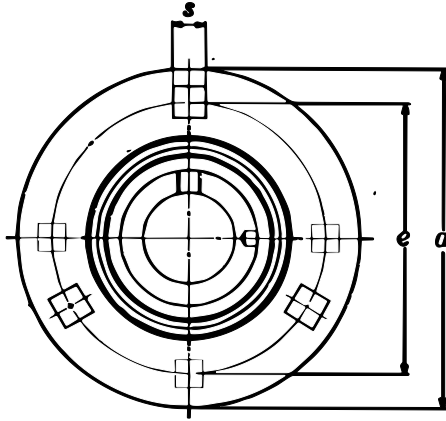

FLANGED UNITS - PRESSED STEEL HOUSING (THREE BOLT)

Shaft Dia.	Complete Flanged Unit Number	Nominal Dimensions										Bolt Size	Housing Number	Bearing Number	Basic Load Ratings (lbs)		Max. Radial Load (lbs)
		a	e	g	s	l	Di	L	n	(min) F	Dynamic C				Static Co		
12 ½	JELPF201 JELPF201-008	81 3 ¾	63 2 15/32	4 .157	7 7/32	14 9/16	29 1.14	28.6 1.126	6.5 .256	49 1 15/16	M6 ¼	PF203 PF203	JEL201 JEL201-008	2160	1030	600	
15 9/16 5/8	JELPF202 JELPF202-009 JELPF202-010	81 3 ¾	63 2 15/32	4 .157	7 7/32	14 9/16	29 1.14	28.6 1.126	6.5 .256	49 1 15/16	M6 ¼	PF203 PF203 PF203	JEL202 JEL202-009 JEL202-010	2160	1030	600	
17 1 1/16	JELPF203 JELPF203-011	81 3 ¾	63 2 15/32	4 .157	7 7/32	14 9/16	29 1.14	28.6 1.126	6.5 .256	49 1 15/16	M6 ¼	PF203 PF203	JEL203 JEL203-011	2160	1030	600	
20 ¾	JELPF204 JELPF204-012	90 3 17/32	71 2 25/32	4 .157	9 23/64	16 5/8	33.3 1.31	31 1.220	7.5 .295	56 2 7/32	M8 5/16	PF204 PF204	JEL204 JEL204-012	2890	1500	660	
25 13/16 7/8 15/16 1	JELPF205 JELPF205-013 JELPF205-014 JELPF205-015 JELPF205-100	95 3 ¾	76 3	4 .157	9 23/64	18 23/32	38.1 1.50	31 1.220	7.5 .295	60 2 3/8	M8 5/16	PF205 PF205 PF205 PF205	JEL205 JEL205-013 JEL205-014 JEL205-015 JEL205-100	3150	1770	880	
30 1 1/16 1 1/8 1 3/16 1 ¼	JELPF206 JELPF206-101 JELPF206-102 JELPF206-103 JELPF206-104	113 4 1/16	90 3 17/32	5.2 .205	11 7/16	18 23/32	44.5 1.75	35.7 1.406	9 .354	71 2 25/32	M10 3/8	PF206 PF206 PF206 PF206 PF206	JEL206 JEL206-101 JEL206-102 JEL206-103 JEL206-104	4400	2540	1100	
35 1 ¼ 1 5/16 1 3/8 1 7/16	JELPF207 JELPF207-104 JELPF207-105 JELPF207-106 JELPF207-107	122 4 13/16	100 3 15/16	5.2 .205	11 7/16	20 25/32	55.6 2.19	38.9 1.531	9.5 .374	81 3 3/16	M10 3/8	PF207 PF207 PF207 PF207 PF207	JEL207 JEL207-104 JEL207-105 JEL207-106 JEL207-107	5750	3450	1300	
40 1 ½ 1 9/16	JELPF208 JELPF208-108 JELPF208-109	148 5 13/16	119 4 11/16	6.8 .268	14 9/16	21 1 1/16	60 2.36	43.7 1.720	11 .433	91 3 9/16	M12 ½	PF208 PF208 PF208	JEL208 JEL208-108 JEL208-109	6550	4000	1500	

Axial load should be less than 1/3 of radial load.
 JELPF208 has four bolt holes.

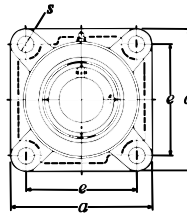
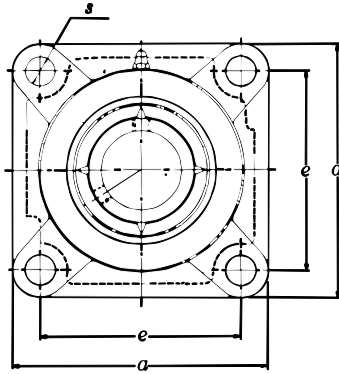

Units: Millimeters
INCHES

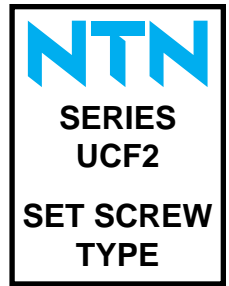

FLANGED UNITS - CAST HOUSING (FOUR BOLT)

Shaft Dia.	Complete Flanged Unit Number	Nominal Dimensions								Bolt Size	Housing Number	Bearing Number	Basic Load Ratings (lbs)	
		a	e	g	l	s	z	Bi	n				Dynamic C	Static C ₀
12 ½	UCF201D1 UCF201-008D1	86 3 ¾	64 2 33/64	11 7/16	25.5 1	12 15/32	33.3 1 5/16	31 1.220	12.7 .500	M10 ¾	F204D1 F204D1	UC201D1 UC201-008D1	2,890	1,500
15 9/16 5/8	UCF202D1 UCF202-009D1 UCF202-010D1	86 3 ¾	64 2 33/64	11 7/16	25.5 1	12 15/32	33.3 1 5/16	31 1.220	12.7 .500	M10 ¾	F204D1 F204D1 F204D1	UC202D1 UC202-009D1 UC202-010D1	2,890	1,500
17 1 1/16	UCF203D1 UCF203-011D1	86 3 ¾	64 2 33/64	11 7/16	25.5 1	12 15/32	33.3 1 5/16	31 1.220	12.7 .500	M10 ¾	F204D1 F204D1	UC203D1 UC203-011D1	2,890	1,500
20 ¾	UCF204D1 UCF204-012D1	86 3 ¾	64 2 33/64	11 7/16	25.5 1	12 15/32	33.3 1 5/16	31 1.220	12.7 .500	M10 ¾	F204D1 F204D1	UC204D1 UC204-012D1	2,890	1,500
25 1 3/16 7/8 1 5/16 1	UCF205D1 UCF205-013D1 UCF205-014D1 UCF205-015D1 UCF205-100D1	95 3 ¾	70 2 ¾	13 ½	27 1 1/16	12 15/32	35.7 1 13/32	34 1.339	14.3 .563	M10 ¾	F205D1 F205D1 F205D1 F205D1 F205D1	UC205D1 UC205-013D1 UC205-014D1 UC205-015D1 UC205-100D1	3,150	1,770
30 1 1/16 1 1/8 1 3/16 1 ¼	UCF206D1 UCF206-101D1 UCF206-102D1 UCF206-103D1 *UCF206-104D1	108 4 ¼	83 3 17/64	13 ½	31 1 7/32	12 15/32	40.2 1 37/64	38.1 1.500	15.9 .626	M10 ¾	F206D1 F206D1 F206D1 F206D1 F206D1	UC206D1 UC206-101D1 UC206-102D1 UC206-103D1 UC206-104D1	4,400	2,540
35 1 ¼ 1 5/16 1 3/8 1 7/16	UCF207D1 UCF207-104D1 UCF207-105D1 UCF207-106D1 *UCF207-107D1	117 4 19/32	92 3 5/8	15 1 9/32	34 1 11/32	14 35/64	44.4 1 ¾	42.9 1.689	17.5 .689	M12 ½	F207D1 F207D1 F207D1 F207D1 F207D1	UC207D1 UC207-104D1 UC207-105D1 UC207-106D1 UC207-107D1	5,750	3,440
40 1 ½ 1 9/16	UCF208D1 UCF208-108D1 UCF208-109D1	130 5 ½	102 4 1/64	15 1 9/32	36 1 13/32	16 5/8	51.2 2 1/64	49.2 1.937	19 .748	M14 ½	F208D1 F208D1 F208D1	UC208D1 UC208-108D1 UC208-109D1	6,550	4,000
45 1 5/8 1 11/16 1 ¾	UCF209D1 UCF209-110D1 UCF209-111D1 UCF209-112D1	137 5 13/32	105 4 9/64	16 5/8	38 1 ½	16 5/8	52.2 2 1/16	49.2 1.937	19 .748	M14 ½	F209D1 F209D1 F209D1 F209D1	UC209D1 UC209-110D1 UC209-111D1 UC209-112D1	7,350	4,590
50 1 13/16 1 7/8 1 15/16 2	UCF210D1 UCF210-113D1 UCF210-114D1 UCF210-115D1 UCF210-200D1	143 5 5/8	111 4 3/8	16 5/8	40 1 9/16	16 5/8	54.6 2 5/32	51.6 2.031	19 .748	M14 ½	F210D1 F210D1 F210D1 F210D1 F210D1	UC210D1 UC210-113D1 UC210-114D1 UC210-115D1 UC210-200D1	7,900	5,220
55 2 2 1/16 2 1/8 2 3/16	UCF211D1 UCF211-200D1 UCF211-201D1 UCF211-202D1 UCF211-203D1	162 6 3/8	130 5 1/8	18 23/32	43 1 11/16	19 ¾	58.4 2 19/64	55.6 2.189	22.2 .874	M16 5/8	F211D1 F211D1 F211D1 F211D1 F211D1	UC211D1 UC211-200D1 UC211-201D1 UC211-202D1 UC211-203D1	9,750	6,570

Continued on next page.

NTN
SERIES
UCF2
SET SCREW
TYPE

Units: Millimeters
 INCHES

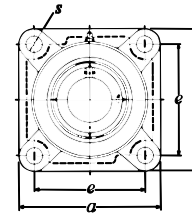
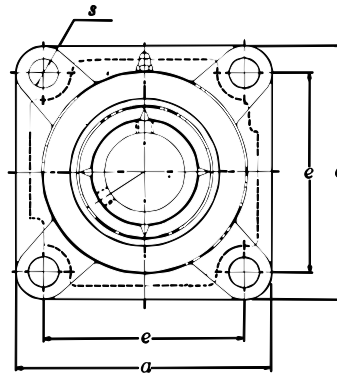

FLANGED UNITS - CAST HOUSING (FOUR BOLT)

Shaft Dia.	Complete Flanged Unit Number	Nominal Dimensions								Bolt Size	Housing Number	Bearing Number	Basic Load Ratings (lbs)	
		a	e	g	l	s	z	Bi	n				Dynamic C	Static C ₀
60 2 1/4 2 3/8 2 7/16	UCF212D1 UCF212-204D1 UCF212-206D1 *UCF212-207D1	175 6 7/8	143 5 5/8	18 23/32	48 1 7/8	19 3/4	68.7 2 45/64	65.1 2.563	25.4 1.000	M16 5/8	F212D1 F212D1 F212D1 F212D1	UC212D1 UC212-204D1 UC212-206D1 UC212-207D1	11,800	8,100
65 2 1/2	UCF213D1 UCF213-208D1	187 7 3/8	149 5 55/64	22 7/8	50 1 31/32	19 3/4	69.7 2 3/4	65.1 2.563	25.4 1.000	M16 5/8	F213D1 F213D1	UC213D1 UC213-208D1	12,900	9,000
70 2 11/16 2 3/4	UCF214D1 UCF214-211D1 UCF214-212D1	193 7 19/32	152 5 63/64	22 7/8	54 2 1/8	19 3/4	75.4 2 31/32	74.6 2.937	30.2 1.189	M16 5/8	F214D1 F214D1 F214D1	UC214D1 UC214-211D1 UC214-212D1	14,000	9,900
75 2 15/16 3	UCF215D1 UCF215-215D1 UCF215-300D1	200 7 7/8	159 6 17/64	22 7/8	56 2 7/32	19 3/4	78.5 3 3/32	77.8 3.063	33.3 1.311	M16 5/8	F215D1 F215D1 F215D1	UC215D1 UC215-215D1 UC215-300D1	14,900	11,100
80 3 1/8	UCF216D1 UCF216-302D1	208 8 3/16	165 6 1/2	22 7/8	58 2 9/32	23 29/32	83.3 3 9/32	82.6 3.252	33.3 1.311	M20 3/4	F216D1 F216D1	UC216D1 UC216-302D1	16,300	11,900
85 3 1/4	UCF217D1 UCF217-304D1	220 8 21/32	175 6 57/64	24 15/16	63 2 15/32	23 29/32	87.6 3 29/64	85.7 3.374	34.1 1.343	M20 3/4	F217D1 F217D1	UC217D1 UC217-304D1	18,700	14,400
90 3 1/2	UCF218D1 UCF218-308D1	235 9 1/4	187 7 23/64	24 15/16	68 2 11/16	23 29/32	96.3 3 51/64	96 3.780	39.7 1.563	M20 3/4	F218D1 F218D1	UC218D1 UC218-308D1	21,600	16,100

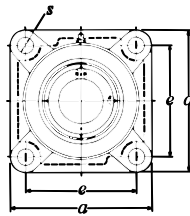
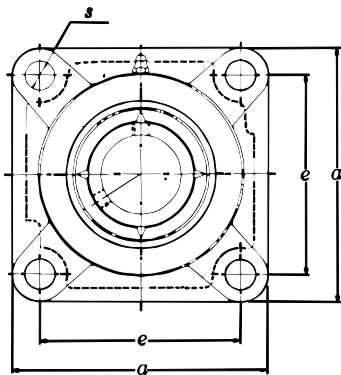

Units: Millimeters
INCHES

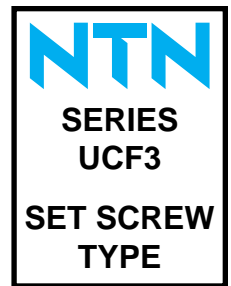

FLANGED UNITS - CAST HOUSING (FOUR BOLT)

Shaft Dia.	Complete Flanged Unit Number	Nominal Dimensions								Bolt Size	Housing Number	Bearing Number	Basic Load Ratings (lbs)	
		a	e	g	l	s	z	Bi	n				Dynamic C	Static Co
25 7/8 15/16 1	UCF305D1 UCF305-014D1 UCF305-015D1 UCF305-100D1	110 4 11/32	80 3 5/32	13 1/2	29 1 5/32	16 5/8	39 1 17/32	38 1.496	15 .591	M14 1/2	F305D1 F305D1 F305D1 F305D1	UC305D1 UC305-014D1 UC305-015D1 UC305-100D1	4,750	2,460
30 1 1/8 1 3/16	UCF306D1 UCF306-102D1 UCF306-103D1	125 4 29/32	95 3 47/64	15 19/32	32 1 1/4	16 5/8	44 1 47/64	43 1.693	17 .669	M14 1/2	F306D1 F306D1 F306D1	UC306D1 UC306-102D1 UC306-103D1	6,000	3,400
35 1 1/4 1 5/16 1 3/8 1 7/16	UCF307D1 UCF307-104D1 UCF307-105D1 UCF307-106D1 UCF307-107D1	135 5 5/16	100 3 15/16	16 5/8	36 1 13/32	19 3/4	49 1 59/64	48 1.890	19 .748	M16 5/8	F307D1 F307D1 F307D1 F307D1 F307D1	UC307D1 UC307-104D1 UC307-105D1 UC307-106D1 UC307-107D1	7,500	4,300
40 1 1/2	UCF308D1 UCF308-108D1	150 5 29/32	112 4 13/32	17 21/32	40 1 9/16	19 3/4	56 2 13/64	52 2.047	19 .748	M16 5/8	F308D1 F308D1	UC308D1 UC308-108D1	9,150	5,400
45 1 5/8 1 11/16 1 3/4	UCF309D1 UCF309-110D1 UCF309-111D1 UCF309-112D1	160 6 5/16	125 4 59/64	18 23/32	44 1 23/32	19 3/4	60 2 23/64	57 2.244	22 .866	M16 5/8	F309D1 F309D1 F309D1 F309D1	UC309D1 UC309-110D1 UC309-111D1 UC309-112D1	11,900	7,200
50 1 7/8 1 15/16	UCF310D1 UCF310-114D1 UCF310-115D1	175 6 7/8	132 5 13/64	19 3/4	48 1 7/8	23 29/32	67 2 41/64	61 2.402	22 .866	M20 3/4	F310D1 F310D1 F310D1	UC310D1 UC310-114D1 UC310-115D1	13,900	8,600
55 2 2 1/8 2 3/16	UCF311D1 UCF311-200D1 UCF311-202D1 UCF311-203D1	185 7 9/32	140 5 33/64	20 25/32	52 2 1/16	23 29/32	71 2 51/64	66 2.598	25 .984	M20 3/4	F311D1 F311D1 F311D1 F311D1	UC311D1 UC311-200D1 UC311-202D1 UC311-203D1	16,100	10,100
60 2 1/4 2 3/8 2 7/16	UCF312D1 UCF312-204D1 UCF312-206D1 UCF312-207D1	195 7 11/16	150 5 29/32	22 7/8	56 2 7/32	23 29/32	78 3 5/64	71 2.795	26 1.024	M20 3/4	F312D1 F312D1 F312D1 F312D1	UC312D1 UC312-204D1 UC312-206D1 UC312-207D1	18,400	11,700
65 2 1/2	UCF313D1 UCF313-208D1	208 8 3/16	166 6 17/32	22 7/8	58 2 9/32	23 29/32	78 3 5/64	75 2.953	30 1.181	M20 3/4	F313D1 F313D1	UC313D1 UC313-208D1	20,800	13,400
70 2 11/16 2 3/4	UCF314D1 UCF314-211D1 UCF314-212D1	226 8 29/32	178 7	25 31/32	61 2 13/32	25 63/64	81 3 3/16	78 3.071	33 1.299	M22 7/8	F314D1 F314D1 F314D1	UC314D1 UC314-211D1 UC314-212D1	23,400	15,300
75 2 15/16 3	UCF315D1 UCF315-215D1 UCF315-300D1	236 9 9/32	184 7 1/4	25 31/32	66 2 19/32	25 63/64	89 3 1/2	82 3.228	32 1.260	M22 7/8	F315D1 F315D1 F315D1	UC315D1 UC315-215D1 UC315-300D1	25,500	17,400
80 3 1/8 3 3/16	UCF316D1 UCF316-302D1 UCF316-303D1	250 9 27/32	196 7 23/32	27 1 1/16	68 2 11/16	31 1 7/32	90 3 35/64	86 3.386	34 1.339	M27 1	F316D1 F316D1 F316D1	UC316D1 UC316-302D1 UC316-303D1	27,600	19,500

Continued on next page.



Units: Millimeters
INCHES

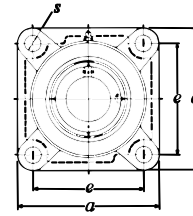
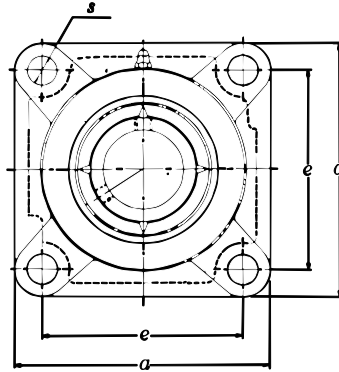

FLANGED UNITS - CAST HOUSING (FOUR BOLT)

Shaft Dia.	Complete Flanged Unit Number	Nominal Dimensions								Bolt Size	Housing Number	Bearing Number	Basic Load Ratings (lbs)	
		<i>a</i>	<i>e</i>	<i>g</i>	<i>l</i>	<i>s</i>	<i>z</i>	<i>Bi</i>	<i>n</i>				Dynamic <i>C</i>	Static <i>C₀</i>
85 3 1/4	UCF317D1 UCF317-304D1	260 10 1/4	204 8 1/32	27 1 1/16	74 2 29/32	31 1 7/32	100 3 15/16	96 3.780	40 1.575	M27 1	F317D1 F317D1	UC317D1 UC317-304D1	29,800	21,800
90 3 7/16 3 1/2	UCF318D1 UCF318-307D1 UCF318-308D1	280 11 1/32	216 8 1/2	30 1 3/16	76 3	35 1 3/8	100 3 15/16	96 3.780	40 1.575	M30 1 1/8	F318D1 F318D1 F318D1	UC318D1 UC318-307D1 UC318-308D1	32,000	24,100
95 3 3/4	UCF319D1 UCF319-312D1	290 11 13/32	228 8 31/32	30 1 3/16	94 3 11/16	35 1 3/8	121 4 49/64	103 4.055	41 1.614	M30 1 1/8	F319D1 F319D1	UC319D1 UC319-312D1	34,500	26,600
100 3 15/16 4	UCF320D1 UCF320-315D1 UCF320-400D1	310 12 7/32	242 9 17/32	32 1 1/4	94 3 11/16	38 1 1/2	125 4 59/64	108 4.252	42 1.654	M33 1 1/4	F320D1 F320D1 F320D1	UC320D1 UC320-315D1 UC320-400D1	39,000	31,500
105	UCF321D1	310	242	32	94	38	127	112	44	M33	F321D1	UC321D1	41,500	34,500
110	UCF322D1	340	266	35	96	41	131	117	46	M36	F322D1	UC322D1	46,000	40,500
120	UCF324D1	370	290	40	110	41	140	126	51	M36	F324D1	UC324D1	46,500	41,500
130	UCF326D1	410	320	45	115	41	146	135	54	M36	F326D1	UC326D1	51,500	48,000
140	UCF328D1	450	350	55	125	41	161	145	59	M36	F328D1	UC328D1	57,000	55,500

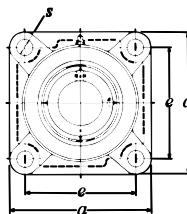
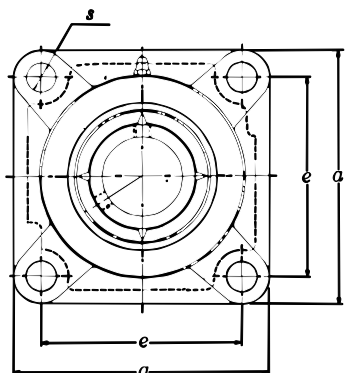

Units: Millimeters
INCHES



FLANGED UNITS - CAST HOUSING (FOUR BOLT)

Shaft Dia.	Complete Flanged Unit Number	Nominal Dimensions								Bolt Size	Housing Number	Bearing Number	Basic Load Ratings (lbs)	
		a	e	g	l	s	z	Bi	n				Dynamic C	Static C ₀
25 1 1/16 7/8 15/16 1	UCFX05D1 UCFX05-013D1 UCFX05-014D1 UCFX05-015D1 UCFX05-100D1	108 4 1/4	83 3 17/64	13 1/2	30 1 3/16	12 15/32	40.2 1 37/64	38.1 1.500	15.9 .626	M10 3/8	FX05D1 FX05D1 FX05D1 FX05D1	UCX05D1 UCX05-013D1 UCX05-014D1 UCX05-015D1 UCX05-100D1	4,390	2,540
30 1 1/8 1 1/8 1 3/16 1 1/4	UCFX06D1 UCFX06-101D1 UCFX06-102D1 UCFX06-103D1 UCFX06-104D1	117 4 19/32	92 3 5/8	14 9/16	34 1 11/32	16 5/8	44.4 1 3/4	42.9 1.689	17.5 .689	M14 1/2	FX06D1 FX06D1 FX06D1 FX06D1	UCX06D1 UCX06-101D1 UCX06-102D1 UCX06-103D1 UCX06-104D1	5,780	3,440
35 1 5/16 1 3/8 1 7/16	UCFX07D1 UCFX07-105D1 UCFX07-106D1 UCFX07-107D1	130 5 1/8	102 4 1/64	14 9/16	38 1 1/2	16 5/8	51.2 2 1/64	49.2 1.937	19 .748	M14 1/2	FX07D1 FX07D1 FX07D1	UCX07D1 UCX07-105D1 UCX07-106D1 UCX07-107D1	6,550	4,000
40 1 1/2 1 9/16	UCFX08D1 UCFX08-108D1 UCFX08-109D1	137 5 13/32	105 4 9/64	14 9/16	40 1 9/16	19 3/4	52.2 2 1/16	49.2 1.937	19 .748	M16 5/8	FX08D1 FX08D1 FX08D1	UCX08D1 UCX08-108D1 UCX08-109D1	7,310	4,590
45 1 5/8 1 11/16 1 3/4 1 13/16	UCFX09D1 UCFX09-110D1 UCFX09-111D1 UCFX09-112D1 UCFX09-113D1	143 5 5/8	111 4 3/8	14 9/16	40 1 9/16	19 3/4	55.6 2 3/16	51.6 2.031	19 .748	M16 5/8	FX09D1 FX09D1 FX09D1 FX09D1	UCX09D1 UCX09-110D1 UCX09-111D1 UCX09-112D1 UCX09-113D1	7,870	5,220
50 1 7/8 1 15/16 2	UCFX10D1 UCFX10-114D1 UCFX10-115D1 UCFX10-200D1	162 6 3/8	130 5 1/8	20 25/32	44 1 23/32	19 3/4	59.4 2 11/32	55.6 2.189	22.2 .874	M16 5/8	FX10D1 FX10D1 FX10D1	UCX10D1 UCX10-114D1 UCX10-115D1 UCX10-200D1	9,780	6,570
55 2 1/16 2 1/8 2 3/16 2 1/4 2 5/16	UCFX11D1 UCFX11-201D1 UCFX11-202D1 UCFX11-203D1 UCFX11-204D1 UCFX11-205D1	175 6 7/8	143 5 5/8	20 25/32	49 1 15/16	19 3/4	68.7 2 45/64	65.1 2.563	25.4 1.000	M16 5/8	FX11D1 FX11D1 FX11D1 FX11D1	UCX11D1 UCX11-201D1 UCX11-202D1 UCX11-203D1 UCX11-204D1 UCX11-205D1	11,810	8,100
60 2 3/8 2 7/16	UCFX12D1 UCFX12-206D1 UCFX12-207D1	187 7 3/8	149 5 55/64	21 13/16	59 2 5/16	19 3/4	73.7 2 29/32	65.1 2.563	25.4 1.000	M16 5/8	FX12D1 FX12D1 FX12D1	UCX12D1 UCX12-206D1 UCX12-207D1	12,930	9,000
65 2 1/2 2 3/16	UCFX13D1 UCFX13-208D1 UCFX13-209D1	187 7 3/8	149 5 55/64	21 13/16	59 2 5/16	19 3/4	78.4 3 3/32	74.6 2.937	30.2 1.189	M16 5/8	FX13D1 FX13D1	UCX13D1 UCX13-208D1 UCX13-209D1	13,940	9,900
70 2 5/8 2 11/16 2 3/4	UCFX14D1 UCFX14-210D1 UCFX14-211D1 UCFX14-212D1	197 7 3/4	152 5 63/64	24 15/16	60 2 3/8	23 29/32	81.5 3 13/64	77.8 3.063	33.3 1.311	M20 3/4	FX14D1 FX14D1 FX14D1	UCX14D1 UCX14-210D1 UCX14-211D1 UCX14-212D1	14,840	11,130

Continued on next page.



Units: Millimeters
INCHES

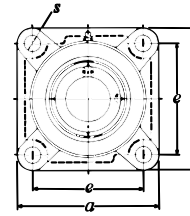
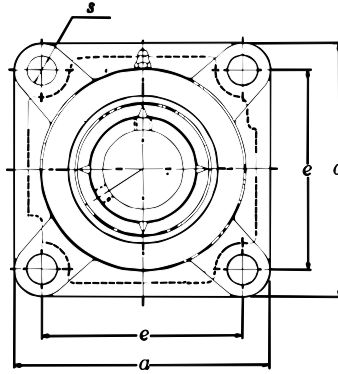

FLANGED UNITS - CAST HOUSING (FOUR BOLT)

Shaft Dia.	Complete Flanged Unit Number	Nominal Dimensions								Bolt Size	Housing Number	Bearing Number	Basic Load Ratings (lbs)	
		<i>a</i>	<i>e</i>	<i>g</i>	<i>l</i>	<i>s</i>	<i>z</i>	<i>Bi</i>	<i>n</i>				Dynamic <i>C</i>	Static <i>C_o</i>
75 2 13/16 2 7/8 2 15/16 3	UCFX15D1 UCFX15-213D1 UCFX15-214D1 UCFX15-215D1 UCFX15-300D1	197 7 3/4	152 5 63/64	24 1 5/16	68 2 11/16	23 29/32	89.3 3 33/64	82.6 3.252	33.3 1.311	M20 3/4	FX15D1 FX15D1 FX15D1 FX15D1	UCX15D1 UCX15-213D1 UCX15-214D1 UCX15-215D1 UCX15-300D1	16,310	11,920
80 3 1/8 3 3/16 3 1/4	UCFX16D1 UCFX16-302D1 UCFX16-303D1 UCFX16-304D1	214 8 7/16	171 6 47/64	24 1 5/16	70 2 3/4	23 29/32	91.6 3 39/64	85.7 3.374	34.1 1.343	M20 3/4	FX16D1 FX16D1 FX16D1 FX16D1	UCX16D1 UCX16-302D1 UCX16-303D1 UCX16-304D1	18,780	14,390
85 3 5/16 3 7/16	UCFX17D1 UCFX17-305D1 UCFX17-307D1	214 8 7/16	171 6 47/64	24 1 5/16	70 2 3/4	23 29/32	96.3 3 51/64	96 3.780	39.7 1.563	M20 M20	FX17D1 FX17D1 FX17D1	UCX17D1 UCX17-305D1 UCX17-307D1	21,590	16,080
90 3 1/2	UCFX18D1 UCFX18-308D1	214 8 7/16	171 6 47/64	24 1 5/16	76 3	23 29/32	106.1 4 11/64	104 4.094	42.9 1.689	M20 3/4	FX18D1 FX18D1	UCX18D1 UCX18-308D1	24,520	18,440
100 3 7/8 3 15/16 4	UCFX20D1 UCFX20-314D1 UCFX20-315D1 UCFX20-400D1	268 10 9/16	211 8 5/16	31 1 7/32	97 3 13/16	31 1 7/32	127.3 5 1/64	117.5 4.626	49.2 1.937	M27 1	FX20D1 FX20D1 FX20D1 FX20D1	UCX20D1 UCX20-314D1 UCX20-315D1 UCX20-400D1	29,910	23,620

Units: Millimeters
INCHES

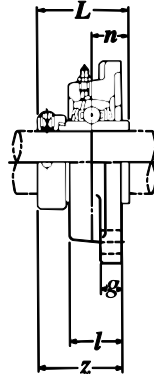
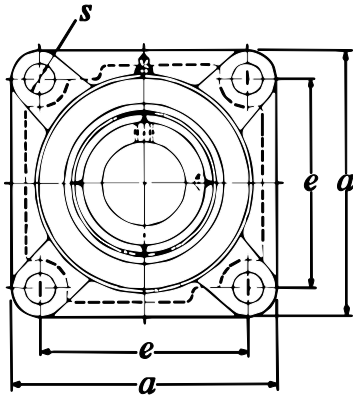

FLANGED UNITS - CAST HOUSING (FOUR BOLT)

Shaft Dia.	Complete Flanged Unit Number	Nominal Dimensions									Bolt Size	Housing Number	Bearing Number	Basic Load Ratings (lbs)	
		a	e	g	l	s	z	L	Di	n				Dynamic C	Static C ₀
20 3/4	UEL204D1 UEL204-012D1	86 3 3/8	64 2 33/64	11 7/16	25.5 1	12 15/32	41.6 1 41/64	43.7 1.720	33 1.299	17.1 .673	M10 5/16	F204D1 F204D1	UEL204D1 UEL204-012D1	2,890	1,500
25 1 3/16 7/8 1 1/8 1 1/4	UEL205D1 UEL205-013D1 UEL205-014D1 UEL205-015D1 UEL205-100D1	95 3 3/4	70 2 3/4	13 1/2	27 1 1/16	12 15/32	42.9 1 11/16	44.4 1.748	38 1.496	17.5 .689	M10 3/8	F205D1 F205D1 F205D1 F205D1 F205D1	UEL205D1 UEL205-013D1 UEL205-014D1 UEL205-015D1 UEL205-100D1	3,150	1,770
30 1 1/16 1 1/8 1 3/16 1 1/4	UEL206D1 UEL206-101D1 UEL206-102D1 UEL206-103D1 UEL206-104D1	108 4 1/4	83 3 17/64	13 1/2	31 1 7/32	12 15/32	48.1 1 57/64	48.4 1.906	44.5 1.752	18.3 .720	M10 3/8	F206D1 F206D1 F206D1 F206D1 F206D1	UEL206D1 UEL206-101D1 UEL206-102D1 UEL206-103D1 UEL206-104D1	4,400	2,540
35 1 1/4 1 5/16 1 3/8 1 7/16	UEL207D1 UEL207-104D1 UEL207-105D1 UEL207-106D1 UEL207-107D1	117 4 19/32	92 3 5/8	15 19/32	34 1 11/32	14 35/64	51.3 2 1/64	51.1 2.012	55.5 2.185	18.8 .740	M12 7/16	F207D1 F207D1 F207D1 F207D1 F207D1	UEL207D1 UEL207-104D1 UEL207-105D1 UEL207-106D1 UEL207-107D1	5,750	3,440
40 1 1/2 1 5/8	UEL208D1 UEL208-108D1 UEL208-109D1	130 5 1/8	102 4 1/64	15 19/32	36 1 13/32	16 5/8	55.9 2 19/64	56.3 2.217	60 2.362	21.4 .843	M14 1/2	F207D1 F208D1 F208D1	UEL208D1 UEL208-108D1 UEL208-109D1	6,550	4,000
45 1 5/8 1 11/16 1 3/4	UEL209D1 UEL209-110D1 UEL209-111D1 UEL209-112D1	137 5 13/32	105 4 9/64	16 5/8	38 1 1/2	16 5/8	56.9 2 19/64	56.3 2.217	63.5 2.500	21.4 .843	M14 1/2	F209D1 F209D1 F209D1 F209D1	UEL209D1 UEL209-110D1 UEL209-111D1 UEL209-112D1	7,350	4,590
50 1 13/16 1 7/8 1 15/16 2	UEL210D1 UEL210-113D1 UEL210-114D1 UEL210-115D1 UEL210-200D1	143 5 5/8	111 4 3/8	16 5/8	40 1 9/16	16 5/8	60.1 2 23/64	62.7 2.469	69.5 2.736	24.6 .969	M14 1/2	F210D1 F210D1 F210D1 F210D1 F210D1	UEL210D1 UEL210-113D1 UEL210-114D1 UEL210-115D1 UEL210-200D1	7,900	5,220
55 2 2 1/16 2 1/8 2 3/16	UEL211D1 UEL211-200D1 UEL211-201D1 UEL211-202D1 UEL211-203D1	162 6 3/8	130 5 1/8	18 23/32	43 1 11/16	19 3/4	68.6 2 45/64	71.4 2.811	76 2.992	27.8 1.094	M16 9/16	F211D1 F211D1 F211D1 F211D1 F211D1	UEL211D1 UEL211-200D1 UEL211-201D1 UEL211-202D1 UEL211-203D1	9,750	6,570
60 2 1/4 2 3/8 2 7/16	UEL212D1 UEL212-204D1 UEL212-206D1 UEL212-207D1	175 6 7/8	143 5 5/8	18 23/32	48 1 7/8	19 3/4	75.8 2 63/64	77.8 3.063	84 3.307	31 1.220	M16 9/16	F212D1 F212D1 F212D1 F212D1	UEL212D1 UEL212-204D1 UEL212-206D1 UEL212-207D1	11,800	8,100
65 2 1/2	UEL213D1 UEL213-208D1	187 7 3/8	149 5 55/64	22 7/8	50 1 31/32	19 3/4	81.55 3 13/64	85.7 3.374	97 3.819	34.15 1.344	M16 9/16	F213D1 F213D1	UEL213D1 UEL213-208D1	12,900	9,000
70 2 11/16 2 3/4	UEL214D1 UEL214-211D1 UEL214-212D1	193 7 19/32	152 5 63/64	22 7/8	54 2 1/8	19 3/4	82.55 3 1/4	85.7 3.374	97 3.819	34.15 1.344	M16 9/16	F214D1 F214D1 F214D1	UEL214D1 UEL214-211D1 UEL214-212D1	14,000	9,900
75 2 15/16 3	UEL215D1 UEL215-215D1 UEL215-300D1	200 7 7/8	159 6 17/64	22 7/8	56 2 7/32	19 3/4	88.7 3 31/64	92 3.622	102 4.016	37.3 1.469	M16 9/16	F215D1 F215D1 F215D1	UEL215D1 UEL215-215D1 UEL215-300D1	14,900	11,130

NTN
SERIES
UELF3
ECCENTRIC
LOCKING
COLLAR
TYPE

Units: Millimeters
 INCHES

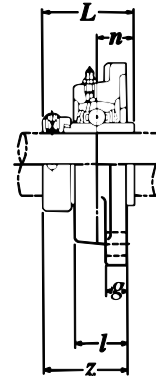
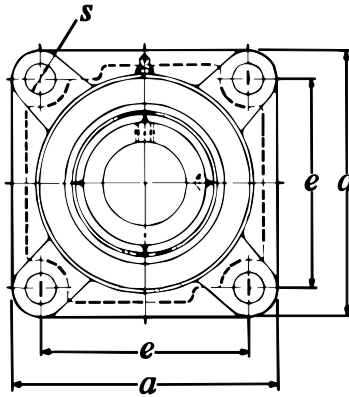

FLANGED UNITS - CAST HOUSING (FOUR BOLT)

Shaft Dia.	Complete Flanged Unit Number	Nominal Dimensions									Bolt Size	Housing Number	Bearing Number	Basic Load Ratings (lbs)	
		a	e	g	l	s	z	L	Di	n				Dynamic C	Static C ₀
25 7/8 1 1/16 1	UELF305D1 UELF305-014D1 UELF305-015D1 UELF305-100D1	110 4 11/32	80 3 5/32	13 1/2	29 1 5/32	16 5/8	46.1 1 13/16	46.8 1.843	42.8 1.685	16.7 .657	M14 1/2	F305D1 F305D1 F305D1 F305D1	UEL305D1 UEL305-014D1 UEL305-015D1 UEL305-100D1	4,750	2,460
30 1 1/8 1 3/16	UELF306D1 UELF306-102D1 UELF306-103D1	125 4 29/32	95 3 47/64	15 19/32	32 1 1/4	16 5/8	50.5 1 63/64	50 1.969	50 1.969	17.5 .689	M14 1/2	F306D1 F306D1 F306D1	UEL306D1 UEL306-102D1 UEL306-103D1	6,000	3,400
35 1 1/4 1 5/16 1 3/8 1 7/16	UELF307D1 UELF307-104D1 UELF307-105D1 UELF307-106D1 UELF307-107D1	135 5 5/16	100 3 15/16	16 5/8	36 1 13/32	19 3/4	53.3 2 3/32	51.6 2.031	55 2.165	18.3 .720	M16 5/8	F307D1 F307D1 F307D1 F307D1 F307D1	UEL307D1 UEL307-104D1 UEL307-105D1 UEL307-106D1 UEL307-107D1	7,500	4,300
40 1 1/2	UELF308D1 UELF308-108D1	150 5 29/32	112 4 13/32	17 2 1/32	40 1 9/16	19 3/4	60.3 2 3/8	57.1 2.248	63.5 2.500	19.8 .780	M16 5/8	F308D1 F308D1	UEL308D1 UEL308-108D1	9,150	5,400
45 1 5/8 1 11/16 1 3/4	UELF309D1 UELF309-110D1 UELF309-111D1 UELF309-112D1	160 6 5/16	125 4 59/64	18 23/32	44 1 23/32	19 3/4	63.9 2 39/64	58.7 2.311	70 2.756	19.8 .780	M16 5/8	F309D1 F309D1 F309D1 F309D1	UEL309D1 UEL309-110D1 UEL309-111D1 UEL309-112D1	11,900	7,200
50 1 7/8 1 15/16	UELF310D1 UELF310-114D1 UELF310-115D1	175 6 7/8	132 5 13/64	19 3/4	48 1 7/8	23 29/32	70 2 3/4	66.6 2.622	76.2 3.000	24.6 .969	M20 3/4	F310D1 F310D1 F310D1	UEL310D1 UEL310-114D1 UEL310-115D1	13,900	8,600
55 2 2 1/8 2 3/16	UELF311D1 UELF311-200D1 UELF311-202D1 UELF311-203D1	185 7 9/32	140 5 33/64	20 25/32	52 2 1/16	23 29/32	75.2 2 61/64	73 2.874	83 3.268	27.8 1.094	M20 3/4	F311D1 F311D1 F311D1 F311D1	UEL311D1 UEL311-200D1 UEL311-202D1 UEL311-203D1	16,100	10,100
60 2 1/4 2 3/8 2 7/16	UELF312D1 UELF312-204D1 UELF312-206D1 UELF312-207D1	195 7 11/16	150 5 29/32	22 7/8	56 2 7/32	23 29/32	81.45 3 13/64	79.4 3.126	89 3.504	30.95 1.219	M20 3/4	F312D1 F312D1 F312D1 F312D1	UEL312D1 UEL312-204D1 UEL312-206D1 UEL312-207D1	18,400	11,700
65 2 1/2	UELF313D1 UELF313-208D1	208 8 3/16	166 6 17/32	22 7/8	58 2 9/32	23 29/32	86.15 3 25/64	85.7 3.374	97 3.819	32.55 1.281	M20 3/4	F313D1 F313D1	UEL313D1 UEL313-208D1	20,800	13,400
70 2 11/16 2 3/4	UELF314D1 UELF314-211D1 UELF314-212D1	226 8 29/32	178 7	25 3 1/32	61 2 19/32	25 63/64	93.95 3 45/64	92.1 3.626	102 4.016	34.15 1.344	M22 7/8	F314D1 F314D1 F314D1	UEL314D1 UEL314-211D1 UEL314-212D1	23,400	15,300
75 2 15/16 3	UELF315D1 UELF315-215D1 UELF315-300D1	236 9 9/32	184 7 1/4	25 3 1/32	66 2 19/32	25 63/64	101.7 4	100 3.937	113 4.449	37.3 1.469	M22 7/8	F315D1 F315D1 F315D1	UEL315D1 UEL315-215D1 UEL315-300D1	25,500	17,400
80 3 1/8 3 3/16	UELF316D1 UELF316-302D1 UELF316-303D1	250 9 27/32	196 7 23/32	27 1 1/16	68 2 11/16	31 1 7/32	103.9 4 3/32	106.4 4.189	119 4.685	40.5 1.594	M27 1	F316D1 F316D1 F316D1	UEL316D1 UEL316-302D1 UEL316-303D1	27,600	19,500
85 3 1/4	UELF317D1 UELF317-304D1	260 10 1/4	204 8 1/32	27 1 1/16	74 2 29/32	31 1 7/32	111.45 4 29/64	109.5 4.311	127 5.000	42.05 1.656	M27 1	F317D1 F317D1	UEL317D1 UEL317-304D1	29,800	21,800
90 3 7/16 3 1/2	UELF318D1 UELF318-307D1 UELF318-308D1	280 11 1/32	216 8 1/2	30 1 3/16	76 3	35 1 3/8	116.25 4 37/64	115.9 4.563	133 5.236	43.65 1.719	M30 1 1/8	F318D1 F318D1 F318D1	UEL318D1 UEL318-307D1 UEL318-308D1	32,000	24,100
95 3 3/4	UELF319D1 UELF319-312D1	290 11 13/32	228 8 31/32	30 1 3/16	94 3 11/16	35 1 3/8	142.4 5 39/64	122.3 4.815	140 5.512	38.9 1.531	M30 1 1/8	F319D1 F319D1	UEL319D1 UEL319-312D1	34,500	26,600
100 3 15/16 4	UELF320D1 UELF320-315D1 UELF320-400D1	310 12 7/32	242 9 17/32	32 1 1/4	94 3 11/16	38 1 1/2	137.6 5 27/64	128.6 5.063	146 5.748	50 1.969	M33 1 1/4	F320D1 F320D1 F320D1	UEL320D1 UEL320-315D1 UEL320-400D1	39,000	31,500
105	UELF321D1	310	242	32	94	38	150.3	139.7	157	48.4	M33	F321D1	UEL321D1	41,500	34,500
110	UELF322D1	340	266	35	96	41	152.1	141.3	168	49.2	M36	F322D1	UEL322D1	46,000	40,500

Units: Millimeters
INCHES

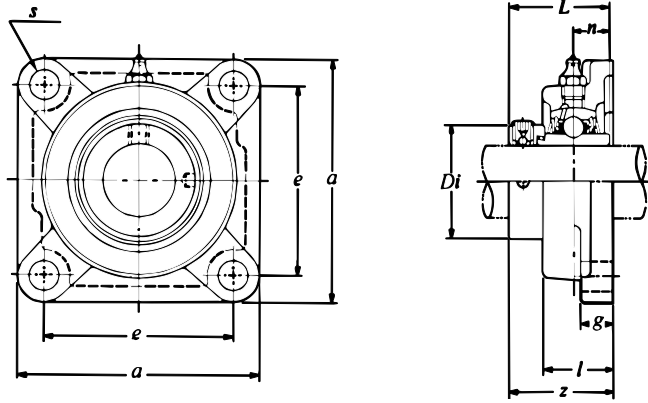

FLANGED UNITS - CAST HOUSING (FOUR BOLT)

Shaft Dia.	Complete Flanged Unit Number	Nominal Dimensions										Bolt Size	Housing Number	Bearing Number	Basic Load Ratings (lbs)	
		a	e	g	l	s	z	L	Di	n	Dynamic C				Static Co	
20 3/4	UEL204D1 UEL204-012D1	86 3 3/8	63.5 2 1/2	15 19/32	29.5 1 5/32	11.5 25/64	45.6 1 51/64	43.7 1.720	33.3 1.31	17.1 .673	M10 5/16	FU204D1 FU204D1	UEL204D1 UEL204-012D1	2,890	1,500	
25 1 1/16 7/8 1 1/8 1 1/4	UEL205D1 UEL205-013D1 UEL205-014D1 UEL205-015D1 UEL205-100D1	96 3 25/32	70 2 3/4	15 19/32	30 1 3/16	11.5 29/64	45.9 1 13/16	44.4 1.748	38.1 1.50	17.5 .689	M10 3/8	FU205D1 FU205D1 FU205D1 FU205D1	UEL205D1 UEL205-013D1 UEL205-014D1 UEL205-015D1 UEL205-100D1	3,150	1,770	
30 1 1/8 1 1/4 1 1/2 1 3/4 1 7/8	UEL206D1 UEL206-101D1 UEL206-102D1 UEL206-103D1 UEL206-104D1	109 4 5/32	82.5 3 1/4	16 5/8	33 1 3/16	11.5 29/64	50.1 1 31/32	48.4 1.906	44.5 1.75	18.3 .720	M10 3/8	FU206D1 FU206D1 FU206D1 FU206D1	UEL206D1 UEL206-101D1 UEL206-102D1 UEL206-103D1 UEL206-104D1	4,400	2,540	
35 1 1/4 1 5/8 1 3/4 1 7/8	UEL207D1 UEL207-104D1 UEL207-105D1 UEL207-106D1 UEL207-107D1	118 4 21/32	92 3 5/8	17 21/32	36 1 13/32	14 35/64	53.3 2 3/32	51.1 2.012	55.6 2.19	18.8 .740	M12 7/16	FU207D1 FU207D1 FU207D1 FU207D1	UEL207D1 UEL207-104D1 UEL207-105D1 UEL207-106D1 UEL207-107D1	5,750	3,440	
40 1 1/2 1 5/8	UEL208D1 UEL208-108D1 UEL208-109D1	131 5 5/32	101.5 4	17 21/32	39 1 17/32	14 35/64	58.9 2 5/16	56.3 2.217	60.2 2.37	21.4 .843	M12 7/16	FU207D1 FU208D1 FU208D1	UEL208D1 UEL208-108D1 UEL208-109D1	6,550	4,000	
45 1 5/8 1 11/16 1 3/4	UEL209D1 UEL209-110D1 UEL209-111D1 UEL209-112D1	137 5 13/32	105 4 9/64	18 23/32	40 1 9/16	16 5/8	58.9 2 5/16	56.3 2.217	63.5 2.50	21.4 .843	M14 1/2	FU209D1 FU209D1 FU209D1	UEL209D1 UEL209-110D1 UEL209-111D1 UEL209-112D1	7,350	4,590	
50 1 13/16 1 7/8 1 15/16 2	UEL210D1 UEL210-113D1 UEL210-114D1 UEL210-115D1 UEL210-200D1	144 5 21/32	111 4 3/8	20 25/32	46 1 13/16	18 45/64	66.1 2 39/64	62.7 2.469	69.9 2.75	24.6 .969	M16 1/2	FU210D1 FU210D1 FU210D1 FU210D1	UEL210D1 UEL210-113D1 UEL210-114D1 UEL210-115D1 UEL210-200D1	7,900	5,220	
55 2 2 1/16 2 1/8 2 3/16	UEL211D1 UEL211-200D1 UEL211-201D1 UEL211-202D1 UEL211-203D1	163 6 13/32	130 5 1/8	21 13/16	49 1 15/16	18 45/64	74.6 2 15/16	71.4 2.811	76.2 3.00	27.8 1.094	M16 9/16	FU211D1 FU211D1 FU211D1 FU211D1	UEL211D1 UEL211-200D1 UEL211-201D1 UEL211-202D1 UEL211-203D1	9,750	6,570	
60 2 1/4 2 3/8 2 7/16	UEL212D1 UEL212-204D1 UEL212-206D1 UEL212-207D1	175 6 7/8	143 5 5/8	21 13/16	53 2 3/32	18 45/64	80.8 3 3/16	77.8 3.063	84.1 3.31	31 1.220	M16 9/16	FU212D1 FU212D1 FU212D1	UEL212D1 UEL212-204D1 UEL212-206D1 UEL212-207D1	11,800	8,100	
65 2 1/2	UEL213D1 UEL213-208D1	187 7 3/8	149 5 59/64	22 7/8	59 2 3/16	20.5 13/16	89.55 3 17/32	85.7 3.374	97.0 3.82	34.15 1.344	M18 5/8	FU213D1 FU213D1	UEL213D1 UEL213-208D1	12,900	9,000	
70 2 11/16 2 3/4	UEL214D1 UEL214-211D1 UEL214-212D1	193 7 19/32	152 5 63/64	22 7/8	62 2 7/16	20.5 13/16	89.55 3 17/32	85.7 3.374	97.0 3.82	34.15 1.344	M18 5/8	FU214D1 FU214D1	UEL214D1 UEL214-211D1 UEL214-212D1	14,000	9,900	
75 2 15/16 3	UEL215D1 UEL215-215D1 UEL215-300D1	200 7 7/8	159 6 17/64	22 7/8	65 2 9/16	20.5 13/16	95.7 3 49/64	92 3.622	102 4.02	37.3 1.469	M18 5/8	FU215D1 FU215D1	UEL215D1 UEL215-215D1 UEL215-300D1	14,900	11,130	

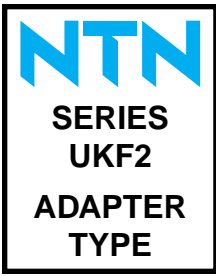

Units: Millimeters
INCHES

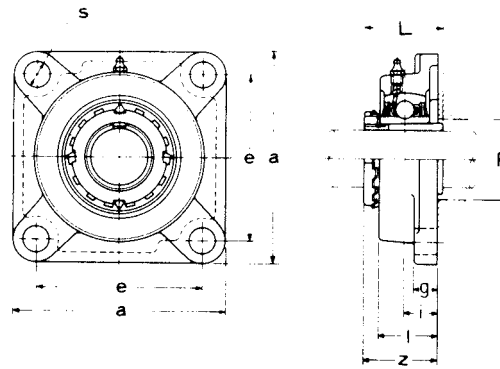

FLANGED UNITS - CAST HOUSING (4 BOLT)

Shaft Dia.	Unit Number 1) 2) 3)	Nominal Dimensions									Bolt Size mm inch	Housing Number	Bearing and Adapter Number	Basic Load Ratings (lbs)	
		a	e	i	g	l	s	z	L	F min				Dynamic C	Static C ₀
20 3/4	UKF205D1 ; H 2305X UKF205D1 ; HE2305	95 3 3/4	70 2 3/4	16 5/8	13 1/2	27 1 1/16	12 15/32	35.5 1 25/64	35 1.378	30 1 3/16	M10 3/8	F205D1	UK205D1 ; H 2305X UK205D1 ; HE2305	3,150	1,770
25 7/8 1	UKF206D1 ; H 2306X UKF206D1 ; HS2306 UKF206D1 ; HE2306X	108 4 1/4	83 3 9/32	18 45/64	13 1/2	31 1 7/32	12 15/32	39 1 17/32	38 1.496	36 1.406	M10 3/8	F206D1	UK206D1 ; H 2306X UK206D1 ; HS2306 UK206D1 ; HE2306X	4,400	2,540
30 1 1/8	UKF207D1 ; H 2307X UKF207D1 ; HS2307	117 4 19/32	92 3 5/8	19 3/4	15 19/32	34 1 11/32	14 35/64	42.5 1 43/64	43 1.693	40 1 9/16	M12 1/2	F207D1	UK207D1 ; H 2307X UK207D1 ; HS2307	5,750	3,440
35 1 1/4 1 3/8	UKF208D1 ; HE2308X UKF208D1 ; H 2308X UKF208D1 ; HS2308X	130 5 1/8	102 4 1/32	21 53/64	15 19/32	36 1 13/32	16 5/8	46.5 1 53/64	46 1.811	46 1 13/16	M14 1/2	F208D1	UK208D1 ; H 2308X UK208D1 ; HE2308X UK208D1 ; HS2308X	6,550	4,000
40 1 7/16 1 1/2 1 5/8	UKF209D1 ; H 2309X UKF209D1 ; HA2309 UKF209D1 ; HE2309X UKF209D1 ; HS2309X	137 5 13/32	105 4 1/8	22 55/64	16 5/8	38 1 1/2	16 5/8	48.5 1 29/32	50 1.969	52 2 1/16	M14 1/2	F209D1	UK209D1 ; H 2309X UK209D1 ; HA2309 UK209D1 ; HE2309X UK209D1 ; HS2309X	7,350	4,600
45 1 9/8 1 11/16 1 3/4	UKF210D1 ; H 2310X UKF210D1 ; HS2310 UKF210D1 ; HA2310 UKF210D1 ; HE2310X	143 5 5/8	111 4 3/8	22 55/64	16 5/8	40 1 9/16	16 5/8	50 1 31/32	55 2.165	57 2 1/4	M14 1/2	F210D1	UK210D1 ; H 2310X UK210D1 ; HS2310 UK210D1 ; HA2310 UK210D1 ; HE2310X	7,900	5,200
50 1 7/8 1 15/16 2	UKF211D1 ; H 2311X UKF211D1 ; HS2311 UKF211D1 ; HA2311 UKF211D1 ; HE2311XY	162 6 3/8	130 5 1/8	25 63/64	18 23/32	43 1 11/16	19 3/4	54.5 2 9/64	59 2.323	64 2 17/32	M16 5/8	F211D1	UK211D1 ; H 2311X UK211D1 ; HS2311 UK211D1 ; HA2311 UK211D1 ; HE2311XY	9,750	6,550
55 2 1/8	UKF212D1 ; H 2312X UKF212D1 ; HS2312	175 6 7/8	143 5 5/8	29 1 9/64	18 23/32	48 1 7/8	19 3/4	61 2 13/32	62 2.441	69 2 23/32	M16 5/8	F212D1	UK212D1 ; H 2312X UK212D1 ; HS2312	11,800	8,150
60 2 3/16 2 1/4 2 3/8	UKF213D1 ; H 2313X UKF213D1 ; HA2313 UKF213D1 ; HE2313 UKF213D1 ; HS2313	187 7 3/8	149 5 7/8	30 1 3/16	22 7/8	50 1 7/32	19 3/4	64 2 33/64	65 2.559	74 2 29/32	M16 5/8	F213D1	UK213D1 ; H 2313X UK213D1 ; HA2313 UK213D1 ; HE2313 UK213D1 ; HS2313	12,900	9,000
65 2 7/16 2 1/2	UKF215D1 ; H 2315X UKF215D1 ; HA2315 UKF215D1 ; HE2315	200 7 7/8	159 6 1/4	34 1 11/32	22 7/8	56 2 7/32	19 3/4	71 2 51/64	73 2.874	84 3 5/16	M16 5/8	F215D1	UK215D1 ; H 2315X UK215D1 ; HA2315 UK215D1 ; HE2315	14,900	11,100
70 2 11/16 2 3/4	UKF216D1 ; H 2316X UKF216D1 ; HA2316 UKF216D1 ; HE2316	208 8 3/16	165 6 1/2	34 1 11/32	22 7/8	58 2 9/32	23 29/32	73.5 2 57/64	78 3.071	90 3 17/32	M20 3/4	F216D1	UK216D1 ; H 2316X UK216D1 ; HA2316 UK216D1 ; HE2316	16,300	11,900
75 2 15/16 3	UKF217D1 ; H 2317X UKF217D1 ; HA2317 UKF217D1 ; HE2317	220 8 21/32	175 6 7/8	36 1 27/64	24 15/16	63 2 15/32	23 29/32	77 3 1/32	82 3.228	95 3 3/4	M20 3/4	F217D1	UK217D1 ; H 2317X UK217D1 ; HA2317 UK217D1 ; HE2317	18,700	14,300
80 3 3/16	UKF218D1 ; H 2318X UKF218D1 ; HA2318	235 9 1/4	187 7 3/8	40 1 37/64	24 15/16	68 2 11/16	23 29/32	81.5 3 13/64	86 3.386	102 4 1/32	M20 3/4	F218D1	UK218D1 ; H 2318X UK218D1 ; HA2318	21,600	16,100

- 1) These numbers indicate re-lubricatable type. If maintenance free type is needed, please order without suffix "D1".
- 2) Adapter number with suffix "X" means a narrow slot type adapter sleeve. In this case the lock washer with the straight inner prong should be used.
- 3) For HE2311XY, screw thread pitch different from the standard is applied, because of the thin thread section of sleeve. To distinguish it, a suffix "Y" is added.

Note: Please refer to NTN Engineering for grease fitting details.



Bearing Series

UCFL2 SERIES

UCFL201D1.....

1.3

Complete Flanged Unit Number

Weight (lbs)

FLANGED UNITS		LBS.					
JELFL208D1.....	3.6	JELFD205.....	1.1	JELPFL206-104.....	1.1	JELPF207-105.....	1.8
JELFL208-108D1.....	3.6	JELFD205-013.....	1.1	JELPFL207.....	1.5	JELPF207-106.....	1.8
JELFL208-109D1.....	3.6	JELFD205-014.....	1.1	JELPFL207-104.....	1.5	JELPF207-107.....	1.9
JELFL209D1.....	4.3	JELFD205-015.....	1.1	JELPFL207-105.....	1.5	JELPF208.....	2.9
JELFL209-110D1.....	4.5	JELFD205-100.....	1.1	JELPFL207-106.....	1.5	JELPF208-108.....	2.9
JELFL209-111D1.....	4.3	JELFD206.....	1.8	JELPFL207-107.....	1.5	JELPF208-109.....	2.9
JELFL209-112D1.....	4.3	JELFD206-101.....	1.8	ASPF2 SERIES		UCF2 SERIES	
JELFL210D1.....	4.8	JELFD206-102.....	1.8	ASPF201.....	0.4	UCF201D1.....	1.5
JELFL210-113D1.....	4.8	JELFD206-103.....	1.8	ASPF201-008.....	0.4	UCF201-008D1.....	1.5
JELFL210-114D1.....	4.8	JELFD206-104.....	1.8	ASPF202.....	0.4	UCF202D1.....	1.5
JELFL210-115D1.....	4.8	JELFD207.....	2.2	ASPF202-009.....	0.4	UCF202-009D1.....	1.5
JELFL210D1.....	5.1	JELFD207-104.....	2.2	ASPF202-010.....	0.4	UCF202-010D1.....	1.5
JELFL210-113D1.....	5.1	JELFD207-105.....	2.2	ASPF203.....	0.4	UCF203D1.....	1.3
JELFL210-114D1.....	5.1	JELFD207-106.....	2.2	ASPF203-011.....	0.4	UCF203-011D1.....	1.3
JELFL210-115D1.....	5.1	JELFD207-107.....	2.2	ASPF204.....	0.7	UCF204D1.....	1.3
JELFL210-200D1.....	5.1	ASPFL2 Series		ASPF204-012.....	0.7	UCF204-012D1.....	1.3
JELFL211D1.....	7.3	ASPFL201.....	0.2	ASPF205.....	0.7	UCF205D1.....	1.8
JELFL211-200D1.....	7.3	ASPFL201-008.....	0.2	ASPF205-013.....	0.7	UCF205-013D1.....	1.8
JELFL211-201D1.....	7.3	ASPFL202.....	0.2	ASPF205-014.....	0.7	UCF205-014D1.....	1.8
JELFL211-202D1.....	7.3	ASPFL202-009.....	0.2	ASPF205-015.....	0.7	UCF205-015D1.....	1.8
JELFL211-203D1.....	7.3	ASPFL202-010.....	0.2	ASPF205-100.....	0.7	UCF205-100D1.....	1.8
JELFL212D1.....	9.5	ASPFL203.....	0.2	ASPF206.....	1.1	UCF206D1.....	2.2
JELFL212-204D1.....	9.5	ASPFL203-011.....	0.2	ASPF206-101.....	1.1	UCF206-101D1.....	2.2
JELFL212-206D1.....	9.5	ASPFL204.....	0.4	ASPF206-102.....	1.1	UCF206-102D1.....	2.2
ASFD2 SERIES		ASPFL204-012.....	0.4	ASPF206-103.....	1.1	UCF206-103D1.....	2.2
ASFD201.....	0.7	ASPFL205.....	0.7	ASPF206-104.....	1.1	UCF206-104D1.....	2.2
ASFD201-008.....	0.7	ASPFL205-013.....	0.7	ASPF207.....	1.5	UCF207D1.....	3.1
ASFD202.....	0.7	ASPFL205-014.....	0.7	ASPF207-104.....	1.5	UCF207-104D1.....	3.1
ASFD202-009.....	0.7	ASPFL205-015.....	0.7	ASPF207-105.....	1.5	UCF207-105D1.....	3.1
ASFD202-010.....	0.7	ASPFL205-100.....	0.7	ASPF207-106.....	1.5	UCF207-106D1.....	3.1
ASFD203.....	0.7	ASPFL206.....	0.9	ASPF207-107.....	1.5	UCF207-107D1.....	3.1
ASFD203-011.....	0.7	ASPFL206-101.....	0.9	ASPF208.....	2.4	UCF208D1.....	4.0
ASFD204.....	0.9	ASPFL206-102.....	0.9	ASPF208-108.....	2.4	UCF208-108D1.....	4.0
ASFD204-012.....	0.9	ASPFL206-103.....	0.9	ASPF208-109.....	2.4	UCF208-109D1.....	4.0
ASFD205.....	1.1	ASPFL206-104.....	0.9	AELPF2 SERIES		UCF209D1.....	4.9
ASFD205-013.....	1.1	ASPFL207.....	1.1	AELPF201.....	0.4	UCF209-110D1.....	4.9
ASFD205-014.....	1.1	ASPFL207-104.....	1.1	AELPF201-008.....	0.4	UCF209-111D1.....	4.9
ASFD205-015.....	1.1	ASPFL207-105.....	1.1	AELPF202.....	0.4	UCF209-112D1.....	4.9
ASFD205-100.....	1.1	ASPFL207-106.....	1.1	AELPF202-009.....	0.4	UCF210D1.....	5.3
ASFD206D1.....	1.8	ASPFL207-107.....	1.1	AELPF202-010.....	0.4	UCF210-113D1.....	5.3
ASFD206-101.....	1.8	AELPFL2 SERIES		AELPF203.....	0.4	UCF210-114D1.....	5.3
ASFD206-102.....	1.8	AELPFL201.....	0.4	AELPF203-011.....	0.4	UCF210-115D1.....	5.3
ASFD206-103.....	1.8	AELPFL201-008.....	0.4	AELPF204.....	0.7	UCF210-200D1.....	5.3
ASFD206-104.....	1.8	AELPFL202.....	0.4	AELPF204-012.....	0.7	UCF211D1.....	7.9
ASFD207.....	2.0	AELPFL202-009.....	0.4	AELPF205.....	0.9	UCF211-200D1.....	7.9
ASFD207-104.....	2.0	AELPFL202-010.....	0.4	AELPF205-013.....	0.9	UCF211-201D1.....	7.9
ASFD207-105.....	2.0	AELPFL203.....	0.4	AELPF205-014.....	0.9	UCF211-202D1.....	7.9
ASFD207-106.....	2.0	AELPFL203-011.....	0.4	AELPF205-015.....	0.9	UCF211-203D1.....	7.9
ASFD207-107.....	2.0	AELPFL204.....	0.7	AELPF205-100.....	0.9	UCF212D1.....	9.7
AELFD2 SERIES		AELPFL204-012.....	0.7	AELPF206.....	1.3	UCF212-204D1.....	9.7
AELFD201.....	0.7	AELPFL205.....	0.7	AELPF206-101.....	1.3	UCF212-206D1.....	9.7
AELFD201-008.....	0.7	AELPFL205-013.....	0.7	AELPF206-102.....	1.3	UCF212-207D1.....	9.7
AELFD202.....	0.7	AELPFL205-014.....	0.7	AELPF206-103.....	1.3	UCF213D1.....	12.0
AELFD202-009.....	0.7	AELPFL205-015.....	0.7	AELPF206-104.....	1.3	UCF213-208D1.....	12.0
AELFD202-010.....	0.7	AELPFL205-100.....	0.7	AELPF207.....	1.8	UCF214D1.....	13.0
AELFD203.....	0.7	AELPFL206.....	1.1	AELPF207-104.....	1.8	UCF214-211D1.....	13.0
AELFD203-011.....	0.7	AELPFL206-101.....	1.1	AELPF207-105.....	1.8	UCF214-212D1.....	13.0
AELFD204.....	1.1	AELPFL206-102.....	1.1	AELPF207-106.....	1.8	UCF215D1.....	15.0
AELFD204-012.....	1.1	AELPFL206-103.....	1.1	AELPF207-107.....	1.9	UCF215-215D1.....	15.0
AELFD205.....	1.1	AELPFL206-104.....	1.1	AELPF208.....	2.9	UCF215-300D1.....	15.0
AELFD205-013.....	1.1	AELPFL207.....	1.5	AELPF208-108.....	2.9	UCF216D1.....	18.0
AELFD205-014.....	1.1	AELPFL207-104.....	1.5	AELPF208-109.....	2.9	UCF216-302D1.....	18.0
AELFD205-015.....	1.1	AELPFL207-105.....	1.5	JELPF2 SERIES		UCF217D1.....	21.0
AELFD205-100.....	1.1	AELPFL207-106.....	1.5	JELPF201.....	0.4	UCF217-304D1.....	21.0
AELFD206.....	1.8	AELPFL207-107.....	1.5	JELPF201-008.....	0.4	UCF218D1.....	24.0
AELFD206-101.....	1.8	JELPFL2 SERIES		JELPF202.....	0.4	UCF218-308D1.....	24.0
AELFD206-102.....	1.8	JELPFL201.....	0.4	JELPF202-009.....	0.4	UCF3 SERIES	
AELFD206-103.....	1.8	JELPFL201-008.....	0.4	JELPF202-010.....	0.4	UCF305D1.....	2.4
AELFD206-104.....	1.8	JELPFL202.....	0.4	JELPF203.....	0.4	UCF305-014D1.....	2.4
AELFD207.....	2.2	JELPFL202-009.....	0.4	JELPF203-011.....	0.4	UCF305-015D1.....	2.4
AELFD207-104.....	2.2	JELPFL202-010.....	0.4	JELPF204.....	0.7	UCF305-100D1.....	2.4
AELFD207-105.....	2.2	JELPFL203.....	0.4	JELPF204-012.....	0.7	UCF306D1.....	3.5
AELFD207-106.....	2.2	JELPFL203-011.....	0.4	JELPF205.....	0.9	UCF306-102D1.....	3.5
AELFD207-107.....	2.2	JELPFL204.....	0.7	JELPF205-013.....	0.9	UCF306-103D1.....	3.5
JELFD2 SERIES		JELPFL204-012.....	0.7	JELPF205-014.....	0.9	UCF307D1.....	4.4
JELFD201.....	0.7	JELPFL205.....	0.7	JELPF205-015.....	0.9	UCF307-104D1.....	4.4
JELFD201-008.....	0.7	JELPFL205-013.....	0.7	JELPF205-100.....	0.9	UCF307-105D1.....	4.4
JELFD202.....	0.7	JELPFL205-014.....	0.7	JELPF206.....	1.3	UCF307-106D1.....	4.4
JELFD202-009.....	0.7	JELPFL205-015.....	0.7	JELPF206-101.....	1.3	UCF307-107D1.....	4.4
JELFD202-010.....	0.7	JELPFL205-100.....	0.7	JELPF206-102.....	1.3	UCF308D1.....	6.0
JELFD203.....	0.7	JELPFL206.....	1.1	JELPF206-103.....	1.3	UCF308-10BD1.....	6.0
JELFD203-011.....	0.7	JELPFL206-101.....	1.1	JELPF206-104.....	1.3	UCF309D1.....	7.5
JELFD204.....	1.1	JELPFL206-102.....	1.1	JELPF207.....	1.8	UCF309-110D1.....	7.5
JELFD204-012.....	1.1	JELPFL206-103.....	1.1	JELPF207-104.....	1.8	UCF309-111D1.....	7.5

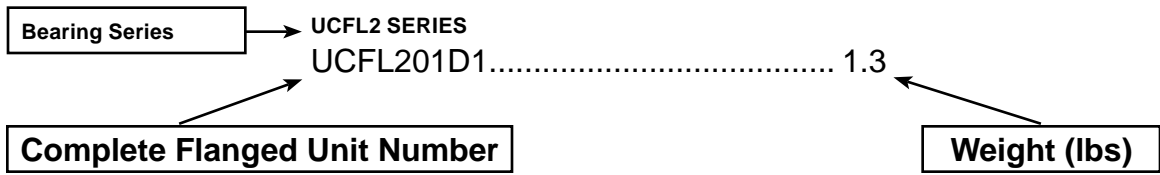

FLANGED UNITS			LBS.
UCF309-112D1	7.5	UCFX15-300D1	18.0
UCF31001	9.9	UCFX16D1	22.0
UCF310-114D1	9.9	UCFX16-302D1	22.0
UCF310-115D1	9.9	UCFX16-303D1	22.0
UCF311D1	12.0	UCFX16-304D1	22.0
UCF311-200D1	12.0	UCFX17D1	24.0
UCF311-202D1	12.0	UCFX17-305D1	24.0
UCF311-203D1	12.0	UCFX17-307D1	24.0
UCF312D1	14.0	UCFX18D1	24.0
UCF312-204D1	14.0	UCFX18-308D1	24.0
UCF312-206D1	14.0	UCFX20D1	37.0
UCF312-207D1	14.0	UCFX20-314D1	37.0
UCF313D1	17.0	UCFX20-315D1	37.0
UCF313-208D1	17.0	UCFX20-400D1	37.0
UCF314D1	21.0	UELF2 SERIES	
UCF314-211D1	21.0	UELF204D1	1.5
UCF314-212D1	21.0	UELF204-012D1	1.5
UCF315D1	26.0	UELF205D1	1.8
UCF315-215D1	26.0	UELF205-013D1	1.8
UCF315-300D1	26.0	UELF205-014D1	1.8
UCF316D1	31.0	UELF205-015D1	1.8
UCF316-302D1	31.0	UELF205-100D1	1.8
UCF316-303D1	31.0	UELF206D1	2.6
UCF317D1	35.0	UELF206-101D1	2.6
UCF317-304D1	35.0	UELF206-102D1	2.6
UCF318D1	42.0	UELF206-103D1	2.6
UCF318-307D1	42.0	UELF206-104D1	2.6
UCF318-308D1	42.0	UELF207D1	3.5
UCF319D1	49.0	UELF207-104D1	3.5
UCF319-312D1	49.0	UELF207-105D1	3.5
UCF320D1	57.0	UELF207-106D1	3.5
UCF320-315D1	57.0	UELF207-107D1	3.5
UCF320-400D1	57.0	UELF208D1	4.2
UCF321D1	60.0	UELF206-108D1	4.2
UCF322D1	84.0	UELF208-109D1	4.2
UCF324D1	110.0	UELF209D1	5.1
UCF326D1	146.0	UELF209-110D1	5.1
UCF328D1	198.0	UELF209-111D1	5.1
		UELF209-112D1	5.1
		UELF210D1	5.7
		UELF210-113D1	5.7
		UELF210-114D1	5.7
		UELF210-115D1	5.7
		UELF210-200D1	5.7
		UELF211D1	8.4
		UELF211-200D1	8.4
		UELF211-201D1	8.4
		UELF211-202D1	8.4
		UELF211-203D1	8.4
		UELF212D1	11.0
		UELF212-204D1	11.0
		UELF212-206D1	11.0
		UELF212-207D1	11.0
		UELF213D1	13.0
		UELF213-208D1	13.0
		UELF214D1	14.0
		UELF214-211D1	14.0
		UELF214-212D1	14.0
		UELF215D1	16.0
		UELF215-215D1	16.0
		UELF215-300D1	16.0
		UELF3 SERIES	
		UELF305D1	2.6
		UELF305-D14D1	2.6
		UELF305-015D1	2.6
		UELF305-100D1	2.6
		UELF306D1	3.7
		UELF306-102D1	3.7
		UELF306-103D1	3.7
		UELF307D1	4.4
		UELF307-104D1	4.4
		UELF307-105D1	4.4
		UELF307-106D1	4.4
		UELF307-107D1	4.4
		UELF308D1	6.2
		UELF308-106D1	6.2
		UELF309D1	7.9
		UELF309-110D1	7.9
		UELF309-111D1	7.9
		UELF309-112D1	7.9
		UELF310D1	10.0
		UELF310-114D1	10.0
		UELF310-115D1	10.0
		UELF311D1	13.0
		UELF311-200D1	13.0
		UELF311-202D1	13.0
		UELF311-203D1	13.0
		UELF312D1	15.0
		UELF312-204D1	15.0
		UELF312-206D1	15.0
		UELF312-207D1	15.0
		UELF313D1	18.0
		UELF313-208D1	18.0
		UELF314D1	22.0
		UELF314-211D1	22.0
		UELF314-212D1	22.0
		UELF315D1	26.0
		UELF315-215D1	26.0
		UELF315-300D1	26.0
		UELF316D1	35.0
		UELF316-302D1	35.0
		UELF316-303D1	35.0
		UELF317D1	37.0
		UELF317-304D1	37.0
		UELF318D1	46.0
		UELF318-307D1	46.0
		UELF318-308D1	46.0
		UELF319D1	51.0
		UELF319-312D1	51.0
		UELF320D1	62.0
		UELF320-315D1	62.0
		UELF320-400D1	62.0
		UELF321D1	64.0
		UELF322D1	88.0
		UELFU2 SERIES	
		UELFU204D1	1.8
		UELFU204-012D1	1.8
		UELFU205D1	2.0
		UELFU205-013D1	2.0
		UELFU205-01401	2.0
		UELFU205-01501	2.0
		UELFU205-100D1	2.0
		UELFU206D1	2.9
		UELFU206-101D1	2.9
		UELFU206-102D1	2.9
		UELFU206-104D1	2.9
		UELFU207D1	4.0
		UELFU207-104D1	4.0
		UELFU207-105D1	4.0
		UELFU207-106D1	4.0
		UELFU207-107D1	4.0
		UELFU208D1	4.6
		UELFU208-108D1	4.6
		UELFU208-109D1	4.6
		UELFU209D1	5.5
		UELFU209-110D1	5.5
		UELFU209-111D1	5.5
		UELFU209-112D1	5.5
		UELFU210D1	6.4
		UELFU210-113D1	6.4
		UELFU210-11401	6.4
		UELFU210-115D1	6.4
		UELFU210-200D1	6.4
		UELFU211D1	9.3
		UELFU211-200D1	9.3
		UELFU211-20101	9.3
		UELFU211-202D1	9.3
		UELFU211-203D1	9.3
		UELFU212D1	11.0
		UELFU212-204D1	11.0
		UELFU212-206D1	11.0
		UELFU212-207D1	11.0
		UELFU213D1	13.0
		UELFU213-208D1	13.0
		UELFU214D1	13.0
		UELFU214-211D1	13.0
		UELFU214-212D1	13.0
		UELFU215D1	17.0
		UELFU215-215D1	17.0
		UELFU215-300D1	17.0
		UKF2SERIES	
		UKF205;H2305X	1.8
		UKF205;HE2305	1.8
		UKF206;H2306X	2.4
		UKF206;HS2306	2.4
		UKF206;HE2306X	2.4
		UKF207;H2307X	3.3
		UKF207;HS2307	3.3
		UKF208;H2308X	4.2
		UKF208;HE2308X	4.2
		UKF209;HS2308X	4.2
		UKF209;H2309X	5.1
		UKF209;HA2309	5.1
		UKF209;HE2309X	5.1
		UKF209;HS2309X	5.1
		UKF210;H2310X	5.7
		UKF210;HS2310	5.7
		UKF210;HE2310X	5.7
		UKF210;HA2310	5.7
		UKF211;H2311X	8.4
		UKF211;HS2311	8.4
		UKF211;HA2311	8.4
		UKF211;HE2311XY	8.4
		UKF212;H2313X	9.9
		UKF212;HS2312	9.9
		UKF212;H2313X	12
		UKF213;HA2313	12
		UKF213;HE2313	12
		UKF213;HS2313	12
		UKF215;H2315X	16
		UKF215;HA2315	16
		UKF215;HE2315	16
		UKF216;H2316X	19
		UKF216;HA2316	19
		UKF216;HE2316	19
		UKF217;H2317	22
		UKF217;HA2317	22
		UKF217;HE2317	22
		UKF218;H2318X	26
		UKF218;HA2318	26



Units: **Millimeters**
INCHES

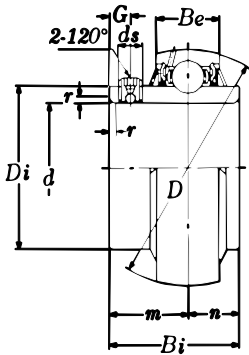

BALL BEARING INSERTS

Bore d	Bearing Number	Nominal Dimensions								Socket Set Screw ds	Basic Load Ratings (lbs)	
		D	Bi	Be	r	n	m	G	Di		Dynamic C	Static C ₀
12 ½	UC201D1 UC201-008D1	47 1.8504	31 1.220	18 .709	1 .039	12.7 .500	18.3 .720	4.5 .177	29.6 1.165	M5 X 0.8 10-32UNF	2,890	1,500
15 ⅝ ⅞	UC202D1 UC202-009D1 UC202-010D1	47 1.8504	31 1.220	18 .709	1 .039	12.7 .500	18.3 .720	4.5 .177	29.6 1.165	M5 X 0.8 10-32UNF	2,890	1,500
17 1 1/16	UC203D1 UC203-011D1	47 1.8504	31 1.220	18 .709	1 .039	12.7 .500	18.3 .720	4.5 .177	29.6 1.165	M5 X 0.8 10-32UNF	2,890	1,500
20 ¾	UC204D1 UC204-012D1	47 1.8504	31 1.220	18 .709	1.5 .059	12.7 .500	18.3 .720	4.5 .177	29.6 1.165	M5 X 0.8 10-32UNF	2,890	1,500
25 1 3/16 7/8 1 1/8 1	UC205D1 UC205-013D1 UC205-014D1 UC205-015D1 UC205-100D1	52 2.0472	34 1.339	18 .709	1.5 .059	14.3 .563	19.7 .776	5 .197	33.9 1.335	M5 X 0.8 10-32UNF	3,150	1,760
30 1 1/16 1 1/8 1 3/16 1 1/4	UC206D1 UC206-101D1 UC206-102D1 UC206-103D1 * UC206-104D1	62 2.4409	38.1 1.500	20 .787	1.5 .059	15.9 .626	22.2 .874	5 .197	40.8 1.606	M6 X 0.75 ¼-28UNF	4,400	2,540
35 1 1/4 1 5/16 1 3/8 1 7/16	UC207D1 UC207-104D1 UC207-105D1 UC207-106D1 * UC207-107D1	72 2.8346	42.9 1.689	22 .866	2 .079	17.5 .689	25.4 1.000	6 .236	46.8 1.843	M6 X 0.75 ¼-28UNF	5,750	3,440
40 1 1/2 1 9/16	UC208D1 UC208-108D1 UC208-109D1	80 3.1496	49.2 1.937	24 .945	2 .079	19 .748	30.2 1.189	8 .315	53 2.087	M8 X 1 5/16-24UNF	6,550	4,000
45 1 5/8 1 11/16 1 3/4	UC209D1 UC209-110D1 UC209-111D1 UC209-112D1	85 3.3465	49.2 1.937	24 .945	2 .079	19 .748	30.2 1.189	8 .315	57.5 2.264	M8 X 1 5/16-24UNF	7,350	4,590
50 1 13/16 1 7/8 1 15/16 2	UC210D1 UC210-113D1 UC210-114D1 UC210-115D1 UC210-200D1	90 3.5433	51.6 2.031	25 .984	2 .079	19 .748	32.6 1.283	9 .354	62.4 2.457	M8 X 1 5/16-24UNF	7,900	5,220
55 2 2 1/16 2 1/8 2 3/16	UC211D1 UC211-200D1 UC211-201D1 UC211-202D1 UC211-203D1	100 3.9370	55.6 2.189	27 1.063	2.5 .098	22.2 .874	33.4 1.315	9 .354	69 2.717	M8 X 1 5/16-24UNF	9,750	6,560
60 2 1/4 2 3/8 2 7/16	UC212D1 UC212-204D1 UC212-206D1 * UC212-207D1	110 4.3307	65.1 2.563	30 1.181	2.5 .098	25.4 1.000	39.7 1.563	10 3.94	77 3.031	M10 X 1.25 ¾-24UNF	11,800	8,100
65 2 1/2	UC213D1 UC213-208D1	120 4.7244	65.1 2.563	32 1.260	2.5 .098	25.4 1.000	39.7 1.563	10 .394	82.5 3.248	M10 X 1.25 ¾-24UNF	12,900	9,000
70 2 11/16 2 3/4	UC214D1 UC214-211D1 UC214-212D1	125 4.9213	74.6 2.937	33 1.299	2.5 .098	30.2 1.189	44.4 1.748	12 .472	87 3.425	M10 X 1.25 ¾-24UNF	14,000	9,900
75 2 15/16 3	UC215D1 UC215-215D1 UC215-300D1	130 5.1181	77.8 3.063	34 1.339	2.5 .098	33.3 1.311	44.5 1.752	12 .472	93 3.661	M10 X 1.25 ¾-24UNF	14,900	11,100
80 3 1/8	UC216D1 UC216-302D1	140 5.5118	82.6 3.252	35 1.378	3 .118	33.3 1.311	49.3 1.941	12 .472	98.1 3.862	M10 X 1.25 ¾-24UNF	16,300	11,900
85 3 1/4	UC217D1 UC217-304D1	150 5.9055	85.7 3.374	36 1.417	3 .118	34.1 1.343	51.6 2.031	12 .472	106.1 4.177	M12 X 1.5 ½-20UNF	18,700	14,400
90 3 1/2	UC218D1 UC218-308D1	160 6.2992	96 3.780	37 1.457	3 .118	39.7 1.563	56.3 2.217	12 .472	111.6 4.394	M12 X 1.5 ½-20UNF	21,600	16,100

*"A-" at front of part number to denote Ultraclass insert.

BALL BEARING INSERTS

Units: Millimeters
INCHES



Bore <i>d</i>	Bearing Number	Nominal Dimensions								Socket Set Screw <i>ds</i>	Basic Load Ratings (lbs)	
		<i>D</i>	<i>Bi</i>	<i>Be</i>	<i>r</i>	<i>n</i>	<i>m</i>	<i>G</i>	<i>Di</i>		Dynamic <i>C</i>	Static <i>C₀</i>
25 1 1/8 15/16 1	UC305D1 UC305-014D1 UC305-015D1 UC305-100D1	62 2.4409	38 1.496	20 .787	2 .079	15 .591	23 .906	6 .236	36.8 1.449	M6 X 0.75 1/4-28UNF	4,750	2,460
30 1 1/8 1 3/16	UC306D1 UC306-102D1 UC306-103D1	72 2.8346	43 1.693	23 .906	2 .079	17 .669	26 1.024	6 .236	44.9 1.768	M6 X 0.75 1/4-28UNF	6,000	3,400
35 1 1/4 1 5/16 1 3/8 1 7/16	UC307D1 UC307-104D1 UC307-105D1 UC307-106D1 UC307-107D1	80 3.1496	48 1.890	25 .984	2.5 .098	19 .748	29 1.142	8 .315	49.4 1.945	M8 X 1 5/16-24UNF	7,500	4,300
40 1 1/2	UC308D1 UC308-108D1	90 3.5433	52 2.047	27 1.063	2.5 .098	19 .748	33 1.299	10 .394	56 2.205	M10 X 1.25 3/8-24UNF	9,150	5,400
45 1 5/8 1 11/16 1 3/4	UC309D1 UC309-110D1 UC309-111D1 UC309-112D1	100 3.9370	57 2.244	29 1.142	2.5 .098	22 .866	35 1.378	10 .394	63.5 2.500	M10 X 1.25 3/8-24UNF	11,900	7,200
50 1 7/8 1 15/16	UC310D1 UC310-114D1 UC310-115D1	110 4.3307	61 2.402	32 1.260	3 .118	22 .866	39 1.535	12 .472	70.6 2.780	M12 X 1.5 1/2-20UNF	13,900	8,660
55 2 2 1/8 2 3/16	UC311D1 UC311-200D1 UC311-202D1 UC311-203D1	120 4.7244	66 2.598	34 1.339	3 .118	25 .984	41 1.614	12 .472	76.6 3.016	M12 X 1.5 1/2-20UNF	16,100	10,100
60 2 1/4 2 3/8 2 7/16	UC312D1 UC312-204D1 UC312-206D1 UC312-207D1	130 5.1181	71 2.795	36 1.417	3.5 .138	26 1.024	45 1.772	12 .472	82.7 3.256	M12 X 1.5 1/2-20UNF	18,400	11,700
65 2 1/2	UC313D1 UC313-208D1	140 5.5118	75 2.953	39 1.535	3.5 .138	30 1.181	45 1.772	12 .472	88.2 3.472	M12 X 1.5 1/2-20UNF	20,800	13,400
70 2 11/16 2 3/4	UC314D1 UC314-211D1 UC314-212D1	150 5.9055	78 3.071	41 1.614	3.5 .138	33 1.299	45 1.772	12 .472	94.8 3.732	M12 X 1.5 1/2-20UNF	23,400	15,300
75 2 15/16 3	UC315D1 UC315-215D1 UC315-300D1	160 6.2992	82 3.228	43 1.693	3.5 .138	32 1.260	50 1.969	14 .551	101.3 3.988	M14 X 1.5 9/16-18UNF	25,500	17,400
80 3 1/8 3 3/16	UC316D1 UC316-302D1 UC316-303D1	170 6.6929	86 3.386	45 1.772	3.5 .138	34 1.339	52 2.047	14 .551	107.9 4.248	M14 X 1.5 9/16-18UNF	27,600	19,500
85 3 1/4	UC317D1 UC317-304D1	180 7.0866	96 3.780	47 1.850	4 .157	40 1.575	56 2.205	16 .630	114.4 4.504	M16 X 1.5 5/8-18UNF	29,800	21,800
90 3 7/16 3 1/2	UC318D1 UC318-307D1 UC318-308D1	190 7.4803	96 3.780	49 1.929	4 .157	40 1.575	56 2.205	16 .630	120.9 4.760	M16 X 1.5 5/8-18UNF	32,000	24,100
95 3 3/4	UC319D1 UC319-312D1	200 7.8740	103 4.055	51 2.008	4 .157	41 1.614	62 2.441	16 .630	127.5 5.020	M16 X 1.5 5/8-18UNF	34,500	26,600
100 3 15/16 4	UC320D1 UC320-315D1 UC320-400D1	215 8.4646	108 4.252	55 2.165	4 .157	42 1.654	66 2.598	18 .709	135.6 5.339	M18 X 1.5 5/8-18UNF	39,000	31,500
105	UC321D1	225	112	57	4	44	68	18	142.1	M18 X 1.5	41,400	34,500
110	UC322D1	240	117	59	4	46	71	18	151.7	M18 X 1.5	46,100	40,500
120	UC324D1	260	126	63	4	51	75	18	165.2	M18 X 1.5	46,600	41,500
130	UC326D1	280	135	67	5	54	81	20	178.3	M20 X 1.5	51,500	48,000
140	UC328D1	300	145	71	5	59	86	20	190.4	M20 X 1.5	56,900	55,500

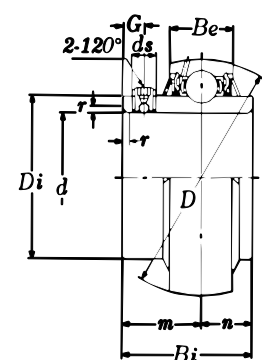

"A-" at front of part number to denote Ultraclass insert.

NTN
SERIES
UCX
SET SCREW
TYPE

Units: **Millimeters**
INCHES

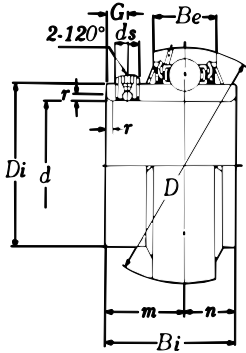

BALL BEARING INSERTS

Bore <i>d</i>	Bearing Number	Nominal Dimensions								Socket Set Screw ds	Basic Load Ratings (lbs)	
		<i>D</i>	<i>Bi</i>	<i>Be</i>	<i>r</i>	<i>n</i>	<i>m</i>	<i>G</i>	<i>Di</i>		Dynamic <i>C</i>	Static <i>C₀</i>
25 1 3/16 7/8 15/16 1	UCX05D1 UCX25-013D1 UCX05-014D1 UCX05-015D1 UCX05-100D1	62 2.4409	38.1 1.500	20 .787	1.5 .059	15.9 .626	22.2 .874	5 .197	40.8 1.606	M6 X 0.75 1/4-28UNF	4,400	2,540
30 1 1/16 1 1/8 1 3/16	UCX06D1 UCX06-101D1 UCX06-102D1 UCX06-102D1	72 2.8346	42.9 1.689	22 .866	1.5 .059	17.5 .689	25.4 1.000	6 .236	46.8 1.843	M8 X 1 5/16-24UNF	5,750	3,440
35 1 5/16 1 3/8 1 7/16	UCX07D1 UCX07-105D1 UCX07-106D1 UCX07-107D1	80 3.1496	49.2 1.937	24 .945	2 .079	19 .748	30.2 1.189	8 .315	53 2.087	M8 X 1 5/16-24UNF	6,550	4,000
40 1 1/2 1 9/16	UCX08D1 UCX08-108D1 UCX08-109D1	85 3.3465	49.2 1.937	24 .945	2 .079	19 .748	30.2 1.189	8 .315	57.5 2.264	M8 X 1 5/16-24UNF	7,350	4,590
45 1 5/8 1 11/16 1 3/4	UCX09D1 UCX09-110D1 UCX09-111D1 UCX09-112D1	90 3.5433	51.6 2.031	25 .984	2 .079	19 .748	32.6 1.283	9 .354	62.4 2.457	M10 X 1.25 3/8-24UNF	7,900	5,220
50 1 7/8 1 15/16	UCX10D1 UCX10-114D1 UCX10-115D1	100 3.9370	55.6 2.189	27 1.063	2 .079	22.2 .874	33.4 1.315	9 .354	69 2.717	M10 X 1.25 3/8-24UNF	9,750	6,560
55 2 1/16 2 1/8 2 3/16	UCX11D1 UCX11-201D1 UCX11-202D1 UCX11-203D1	110 4.3307	65.1 2.563	30 1.181	2.5 .098	25.4 1.000	39.7 1.563	10 .394	77 3.031	M10 X 1.25 3/8-24UNF	11,800	8,100
60 2 3/8 2 7/16	UCX12D1 UCX12-206D1 UCX12-207D1	120 4.7244	65.1 2.563	32 1.260	2.5 .098	25.4 1.000	39.7 1.563	10 .394	82.5 3.248	M10 X 1.25 3/8-24UNF	12,900	9,000
65 2 1/2 2 9/16	UCX13D1 UCX13-208D1 UCX13-209D1	125 4.9213	74.6 2.937	33 1.299	2.5 .098	30.2 1.189	44.4 1.748	12 .472	87 3.425	M12 X 1.5 1/2-20UNF	14,000	9,900
70 2 5/8 2 11/16 2 3/4	UCX14D1 UCX14-210D1 UCX14-211D1 UCX14-212D1	130 5.1181	77.8 3.063	34 1.339	2.5 .098	33.3 1.311	44.5 1.752	12 .472	93 3.661	M12 X 1.5 1/2-20UNF	14,900	11,100
75 2 13/16 2 7/8 2 15/16 3	UCX15D1 UCX15-213D1 UCX15-214D1 UCX15-215D1 UCX15-300D1	140 5.5118	82.6 3.252	35 1.378	2.5 .098	33.3 1.311	49.3 1.941	12 .472	98.1 3.862	M12 X 1.5 1/2-20UNF	16,300	11,900
80 3 1/8 3 3/16	UCX16D1 UCX16-302D1 UCX16-303D1	150 5.9055	85.7 3.374	36 1.417	3 .118	34.1 1.343	51.6 2.031	12 .472	106.1 4.177	M12 X 1.5 1/2-20UNF	18,700	14,400
85 3 5/16 3 7/16	UCX17D1 UCX17-305D1 UCX17-307D1	160 6.2992	96 3.780	37 1.457	3 .118	39.7 1.563	56.3 2.217	12 .472	111.6 4.394	M12 X 1.5 1/2-20UNF	21,600	16,100
90 3 1/2	UCX18D1 UCX18-308D1	170 6.6929	104 4.094	39 1.535	3 .118	42.9 1.689	61.1 2.406	14 .551	118.2 4.654	M14 X 1.5 9/16-18UNF	24,500	18,400
100 3 7/8 3 15/16 4	UCX20D1 UCX20-314D1 UCX20-315D1 UCX20-400D1	190 7.4803	117.5 4.626	44 1.732	3.5 .138	49.2 1.937	68.3 2.689	16 .630	131.3 5.169	M16 X 1.5 5/8-18UNF	29,900	23,600

"A-" at front of part number to denote Ultraclass insert.

BALL BEARING INSERTS – AS2 SERIES

Bore <i>d</i>	Bearing Number	Nominal Dimensions								Socket Set Screw <i>ds</i>	Basic Load Ratings (lbs)		
		<i>D</i>	<i>Bi</i>	<i>Be</i>	<i>r</i>	<i>n</i>	<i>m</i>	<i>G</i>	<i>Di</i>		Dynamic <i>C</i>	Static <i>C₀</i>	
12 ½	AS201 AS201-008	40 1.5748	22 .866	12 .472	1 .039	6 .236	16 .630	4.2 .165	24.4 .961	24.4 10-32UNF	M5 X 0.8	2,160	1,030
15 ⅞ ⅝	AS202 AS202-009 AS202-010	40 1.5748	22 .866	12 .472	1 .039	6 .236	16 .630	4.2 .165	24.4 .961	24.4 10-32UNF	M5 X 0.8	2,160	1,030
17 ⅞ ⅝	AS203 * AS203-011	40 1.5748	22 .866	12 .472	1 .039	6 .236	16 .630	4.2 .165	24.4 .961	24.4 10-32UNF	M5 X 0.8	2,160	1,030
20 ¾	AS204 AS204-012	47 1.8504	25 .984	14 .551	1.5 .059	7 .276	18 .708	4.2 .165	29.6 1.165	29.6 10-32UNF	M5 X 0.8	2,890	1,500
25 1 ⅜ 7/8 1 ⅝ 1	AS205 AS205-013 AS205-014 AS205-015 AS205-100	52 2.0472	27 1.063	15 .591	1.5 .059	7.5 .295	19.5 .768	5 .197	33.9 1.335	33.9 10-32UNF	M5 X 0.8	3,150	1,760
30 1 ⅞ 1 ⅝ 1 ¾ 1 ¼	AS206 AS206-101 AS206-102 AS206-103 * AS206-104	62 2.4409	29 1.142	16 .630	1.5 .059	8 .315	21 .827	5 .197	40.8 1.606	40.8 ¼-28UNF	M6 X 0.75	4,400	2,540
35 1 ¾ 1 ⅝ 1 ⅜ 1 ⅞	AS207 AS207-104 AS207-105 AS207-106 * AS207-107	72 2.8349	34 1.339	17 .669	2 .079	8.5 .335	25.5 1.004	6 .236	46.8 1.843	46.8 ¼-28UNF	M6 X 0.75	5,750	3,440
40 1 ½ 1 ⅞	AS208 AS208-108 AS208-109	80 3.1496	38 1.496	18 .709	2 .079	9 .354	29 1.142	8 .315	53 2.087	53 ⅝-24UNF	M8 X 1	6,540	4,000

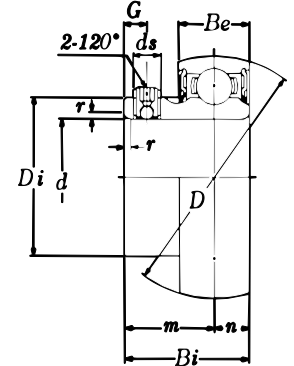

AS2

Units: Millimeters
INCHES



BALL BEARING INSERTS – ASS2 SERIES

Bore <i>d</i>	Bearing Number	Nominal Dimensions											Socket Set Screw <i>ds</i>	Basic Load Ratings (lbs)	
		<i>D</i>	<i>Bi</i>	<i>Be</i>	<i>r</i>	<i>n</i>	<i>m</i>	<i>G</i>	<i>Di</i>	<i>Dn</i>	<i>an</i>	<i>bn</i>		Dynamic <i>C</i>	Static <i>C₀</i>
12 ½	ASS201N ASS201-008N	40 1.5748	22 .866	12 .472	1 .039	6 .236	16 .630	4.2 .165	24.4 .961	38.1 1.500	1.98 .078	1.5 .059	M5 X 0.8	2,160	1,030
15 ⅞ ⅝	ASS202N ASS202-009N ASS202-010N	40 1.5748	22 .866	12 .472	1 .039	6 .236	16 .630	4.2 .165	24.4 .961	38.1 1.500	1.98 .078	1.5 .059	M5 X 0.8	2,160	1,030
17 ⅞ ⅝	ASS203N * ASS203-011N	40 1.5748	22 .866	12 .472	1 .039	6 .236	16 .630	4.2 .165	24.4 .961	38.1 1.500	1.98 .078	1.5 .059	M5 X 0.8	2,160	1,030
20 ¾	ASS204N ASS204-012N	47 1.8504	25 .984	14 .551	1.5 .059	7 .276	18 .708	4.2 .165	29.6 1.165	44.6 1.756	2.38 .094	1.5 .059	M5 X 0.8	2,890	1,500
25 1 ⅜ 7/8 1 ⅝ 1	ASS205N ASS205-013N ASS205-014N ASS205-015N ASS205-100N	52 2.0472	27 1.063	15 .591	1.5 .059	7.5 .295	19.5 .768	5 .197	33.9 1.335	49.73 1.958	2.38 .094	1.5 .059	M5 X 0.8	3,150	1,760
30 1 ⅞ 1 ⅝ 1 ¾ 1 ¼	ASS206N ASS206-101N ASS206-102N ASS206-103N * ASS206-104N	62 2.4409	29 1.142	16 .630	1.5 .059	8 .315	21 .827	5 .197	40.8 1.606	59.61 2.347	3.18 .125	2.05 .081	M6 X 0.75	4,400	2,540
35 1 ¾ 1 ⅝ 1 ⅜ 1 ⅞	ASS207N ASS207-104N ASS207-105N ASS207-106N * ASS207-107N	72 2.8349	34 1.339	17 .669	2 .079	8.5 .335	25.5 1.004	6 .236	46.8 1.843	68.81 2.709	3.18 .125	2.05 .081	M6 X 0.75	5,750	3,440
40 1 ½ 1 ⅞	ASS208N ASS208-108N ASS208-109N	80 3.1496	38 1.496	18 .709	2 .079	9 .354	29 1.142	8 .315	53 2.087	76.81 3.024	3.18 .125	2.05 .081	M8 X 1	6,540	4,000

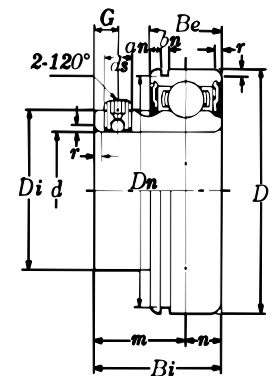

ASS2

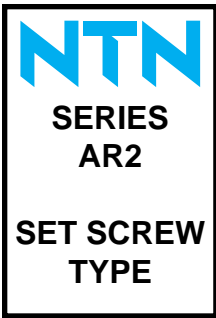

Units: **Millimeters**
INCHES

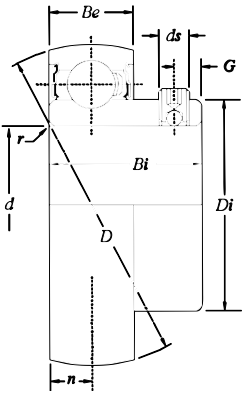

BALL BEARING INSERTS

Bore <i>d</i>	Bearing Number	Nominal Dimensions							Socket Set Screw <i>ds</i>	Basic Load Ratings (lbs)	
		<i>D</i>	<i>Bi</i>	<i>Be</i>	<i>r</i>	<i>n</i>	<i>G</i>	<i>Di</i>		Dynamic <i>C</i>	Static <i>C₀</i>
12 ½	AR201 AR201-008	40 1.5748	22.5 .8858	13 .5118	1 .0394	6.5 .2559	5 .1969	24.4 .9606	M6 X 0.75 ¼-28UNF	1,370	615
15 ⅞ 5/8	AR202 AR202-009 AR202-010	40 1.5748	22.5 .8858	13 .5118	1 .0394	6.5 .2559	5 .1969	24.4 .9606	M6 X 0.75 ¼-28UNF	1,740	805
17 1 1/16	AR203 AR203-011	40 1.5748	22.5 .8858	13 .5118	1 .0394	6.5 .2559	5 .1969	24.4 .9606	M6 X 0.75 ¼-28UNF	2,160	1,030
20 ¾	AR204 AR204-012	47 1.8504	25.5 1.0039	15 .5906	1.5 .0591	7.5 .2953	5 .1969	29.6 1.1654	M6 X 0.75 ¼-28UNF	2,890	1,500
25 1 3/16 7/8 1 1/16 1	AR205 AR205-013 AR205-014 AR205-015 AR205-100	52 2.0472	27 1.0630	15 .5906	1.5 .0591	7.5 .2953	5 .1969	33.9 1.3346	M6 X 0.75 ¼-28UNF	3,150	1,770
30 1 1/16 1 1/8 1 3/16 1 1/4	AR206 AR206-101 AR206-102 AR206-103 AR206-104	62 2.4409	30 1.1811	18 .7087	1.5 .0591	9 .3543	5 .1969	40.8 1.6063	M6 X 0.75 ¼-28UNF	4,400	2,540
35 1 1/4 1 5/16 1 3/8 1 7/16	AR207 AR207-104 AR207-105 AR207-106 AR207-107	72 2.8346	35 1.3780	19 .7480	2 .0787	9.5 .3740	6 .2362	46.8 1.8425	M6 X 0.75 ¼-28UNF	5,750	3,450
40 1 1/2 1 9/16	AR208 AR208-108 AR208-109	80 3.1496	40 1.5748	22 .8661	2 .0787	11 .4331	8 .3150	53 2.0866	M8 X 1 5/16-24UNF	6,550	4,000
45 1 5/8 1 1 1/16 1 3/4	AR209 AR209-110 AR209-111 AR209-112	85 3.3465	41.5 1.6339	22 .8661	2 .0787	11 .4331	8 .3150	57.5 2.2638	M8 X 1 5/16-24UNF	7,350	4,600
50 1 1 3/16 1 7/8 1 1 1/16 2	AR210 AR210-113 AR210-114 AR210-115 AR210-200	90 3.5433	43 1.6929	22 .8661	2 .0787	11 .4331	9 .3543	62.4 2.4567	M8 X 1 5/16-24UNF	7,900	5,200

BALL BEARING INSERTS

Units: Millimeters
INCHES



Bore <i>d</i>	Bearing Number	Nominal Dimensions										Socket Set Screw <i>d_s</i>	Basic Load Ratings (lbs)		
		<i>D</i>	<i>B_i</i>	<i>B_e</i>	<i>r</i>	<i>n</i>	<i>m</i>	<i>G</i>	<i>D_i</i>	<i>D_n</i>	<i>a_n</i>		<i>b_n</i>	Dynamic <i>C</i>	Static <i>C₀</i>
12 ½	UCS201D1N UCS201-008D1N	47 1.8504	31 1.220	18 .079	1 .039	12.7 .500	18.3 .720	4.5 .177	29.6 1.165	44.6 1.756	3.2 .126	1.5 .059	M5 X 0.8 10-32UNF	2,890	1,500
15 ⅝ ⅞	UCS202D1N UCS202-009D1N UCS202-010D1N	47 1.8504	31 1.220	18 .709	1 .039	12.7 .500	18.3 .720	4.5 .177	29.6 1.165	44.6 1.756	3.2 .126	1.5 .059	M5 X 0.8 10-32UNF	2,890	1,500
17 ⅞	UCS203D1N UCS203-011D1N	47 1.8504	31 1.220	18 .709	1 .039	12.7 .500	18.3 .720	4.5 .177	29.6 1.165	44.6 1.756	3.2 .126	1.5 .059	M5 X 0.8 10-32UNF	2,890	1,500
20 ¾	UCS204D1N UCS204-012D1N	47 1.8504	31 1.220	18 .709	1.5 .059	12.7 .500	18.3 .720	4.5 .177	29.6 1.165	44.6 1.756	3.2 .126	1.5 .059	M5 X 0.8 10-32UNF	2,890	1,500
25 1⅜ 7/8 15/16 1	UCS205D1N UCS205-013D1N UCS205-014D1N UCS205-015D1N UCS205-100D1N	52 2.0472	34 1.339	18 .709	1.5 .059	14.3 .563	19.7 .776	5 .197	33.9 1.335	49.73 1.958	3.2 .126	1.5 .059	M5 X 0.8 10-32UNF	3,150	1,760
30 1 1/16 1 1/8 1 3/16	UCS206D1N UCS206-101D1N UCS206-102D1N UCS206-103D1N	62 2.4409	38.1 1.500	20 .787	1.5 .059	15.9 .626	22.2 .874	5 .197	40.8 1.606	59.61 2.347	3.5 .138	2.05 .081	M6 X 0.75 ¼-28UNF	4,400	2,540
35 1 1/4 1 5/16 1 3/8 1 7/16	UCS207D1N UCS207-104D1N UCS207-105D1N UCS207-106D1N *UCS207-107D1N	72 2.8346	42.9 1.689	22 .866	2 .079	17.5 .689	25.4 1.000	6 .236	46.8 1.843	68.81 2.709	3.7 .146	2.05 .081	M6 X 0.75 ¼-28UNF	5,750	3,440
40 1 1/2 1 5/8	UCS208D1N UCS208-108D1N UCS208-109D1N	80 3.1496	49.2 1.937	24 .945	2 .079	19 .748	30.2 1.189	8 .315	53 2.087	76.81 3.024	3.7 .146	2.05 .081	M8 X 1 5/16-24UNF	6,550	4,000
45 1 5/8 1 11/16 1 3/4	UCS209D1N UCS209-110D1N UCS209-111D1N UCS209-112D1N	85 3.3465	49.2 1.937	24 .945	2 .079	19 .748	30.2 1.189	8 .315	57.5 2.264	81.81 3.221	3.7 .146	2.05 .081	M8 X 1 5/16-24UNF	7,350	4,590
50 1 13/16 1 7/8 1 15/16	UCS210D1N UCS210-113D1N UCS210-114D1N UCS210-115D1N	90 3.5433	51.6 2.031	25 .984	2 .079	19 .748	32.6 1.283	9 .354	62.4 2.457	86.79 3.417	4 .157	2.85 .112	M8 X 1 5/16-24UNF	7,900	5,220
55 2 2 1/16 2 1/8 2 3/16	UCS211D1N UCS211-200D1N UCS211-201D1N UCS211-202D1N UCS211-203D1N	100 3.9370	55.6 2.189	27 1.063	2.5 .098	22.2 .874	33.4 1.315	9 .354	69 2.717	96.8 3.811	4.5 .177	2.85 .112	M8 X 1 5/16-24UNF	9,750	6,560
60 2 1/4 2 3/8 2 7/16	UCS212D1 UCS212-204D1 UCS212-206D1 *UCS212-207D1	110 4.3307	65.1 2.563	30 1.181	2.5 .098	25.4 1.000	39.7 1.563	10 .394	77 3.031	— —	— —	— —	M10 X 1.25 ¾-24UNF	11,800	8,100
65 2 1/2	UCS213D1 UCS213-208D1	120 4.7244	65.1 2.563	32 1.260	2.5 .098	25.4 1.000	39.7 1.563	10 .394	82.5 3.248	— —	— —	— —	M10 X 1.25 ¾-24UNF	12,900	9,000
70	UCS214D1	125	74.6	33	2.5	30.2	44.4	12	87	—	—	—	M10 X 1.25	14,000	9,900
75	UCS215D1	130	77.8	34	2.5	33.3	44.5	12	93	—	—	—	M10 X 1.25	14,900	11,100
80	UCS216D1	140	82.6	35	3	33.3	49.3	12	98.1	—	—	—	M10 X 1.25	16,300	11,900
85	UCS217D1	150	85.7	36	3	34.1	51.6	12	106.1	—	—	—	M12 X 1.5	18,700	14,300
90	UCS218D1	160	96	37	3	39.7	56.3	12	111.6	—	—	—	M12 X 1.5	21,600	16,100

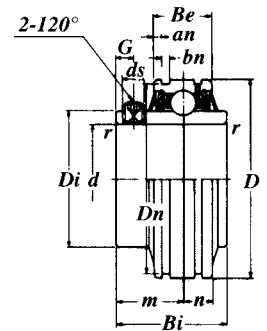

UCS•••D1N

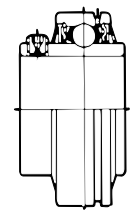

UCS•••D1



Units: **Millimeters**
INCHES

BALL BEARING INSERTS

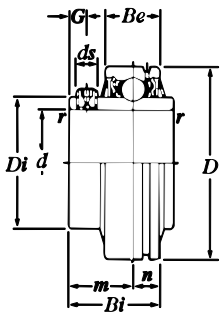

Bore <i>d</i>	Bearing Number	Nominal Dimensions								Socket Set Screw <i>ds</i>	Basic Load Ratings (lbs)	
		<i>D</i>	<i>Bi</i>	<i>Be</i>	<i>r</i>	<i>n</i>	<i>m</i>	<i>G</i>	<i>Di</i>		Dynamic <i>C</i>	Static <i>C₀</i>
25 7/8 15/16 1	UCS305D1 UCS305-014D1 UCS305-015D1 UCS305-100D1	62 2.4409	38 1.496	20 .787	2 .079	15 .591	23 .906	6 .236	36.8 1.449	M6 X 0.75 1/4-28UNF	4,770	2,450
30 1 1/8 1 3/16	UCS306D1 UCS306-102D1 UCS306-103D1	72 2.8346	43 1.693	23 .906	2 .079	17 .669	26 1.024	6 .236	44.9 1.768	M6 X 0.75 1/4-28UNF	6,000	3,370
35 1 1/4 1 5/16 1 3/8 1 7/16	UCS307D1 UCS307-104D1 UCS307-105D1 UCS307-106D1 UCS307-107D1	80 3.1496	48 1.890	25 .984	2.5 .098	19 .748	29 1.142	8 .315	49.4 1.945	M8 X 1 5/16-24UNF	7,530	4,290
40 1 1/2	UCS308D1 UCS308-108D1	90 3.5433	52 2.047	27 1.063	2.5 .098	19 .748	33 1.299	10 .394	56 2.205	M10 X 1.25 3/8-24UNF	9,100	5,400
45 1 5/8 1 11/16 1 3/4	UCS309D1 UCS309-110D1 UCS309-111D1 UCS309-112D1	100 3.9370	57 2.244	29 1.142	2.5 .098	22 .866	35 1.378	10 .394	63.5 2.500	M10 X 1.25 3/8-24UNF	11,900	7,200
50 1 7/8 1 15/16	UCS310D1 UCS310-114D1 UCS310-115D1	110 4.3307	61 2.402	32 1.260	3 .118	22 .866	39 1.535	12 .472	70.6 2.780	M12 X 1.5 1/2-20UNF	13,900	8,660
55 2 2 1/8 2 3/16	UCS311D1 UCS311-200D1 UCS311-202D1 UCS311-203D1	120 4.7244	66 2.598	34 1.339	3 .118	25 .984	41 1.614	12 .472	76.6 3.016	M12 X 1.5 1/2-20UNF	16,100	10,100
60 2 1/4 2 3/8 2 7/16	UCS312D1 UCS312-204D1 UCS312-206D1 UCS312-207D1	130 5.1181	71 2.795	36 1.417	3.5 .138	26 1.024	45 1.772	12 .472	82.7 3.256	M12 X 1.5 1/2-20UNF	18,400	11,700
65 2 1/2	UCS313D1 UCS313-208D1	140 5.5118	75 2.953	39 1.535	3.5 .138	30 1.181	45 1.772	12 .472	88.2 3.472	M12 X 1.5 1/2-20UNF	20,800	13,500
70 2 11/16 2 3/4	UCS314D1 UCS314-211D1 UCS314-212D1	150 5.9055	78 3.071	41 1.614	3.5 .138	33 1.299	45 1.772	12 .472	94.8 3.732	M12 X 1.5 1/2-20UNF	23,400	15,300
75 2 15/16 3	UCS315D1 UCS315-215D1 UCS315-300D1	160 6.2992	82 3.228	43 1.693	3.5 .138	32 1.260	50 1.969	14 .551	101.3 3.988	M14 X 1.5 9/16-18UNF	25,400	17,300
80 3 1/8 3 3/16	UCS316D1 UCS316-302D1 UCS316-303D1	170 6.6929	86 3.386	45 1.772	3.5 .138	34 1.339	52 2.047	14 .551	107.9 4.248	M14 X 1.5 9/16-18UNF	27,700	19,400
85 3 1/4	UCS317D1 UCS317-304D1	180 7.0866	96 3.780	47 1.850	4 .157	40 1.575	56 2.205	16 .630	114.4 4.504	M16 X 1.5 5/8-18UNF	29,900	21,800
90 3 7/16 3 1/2	UCS318D1 UCS318-307D1 UCS318-308D1	190 7.4803	96 3.780	49 1.929	4 .157	40 1.575	56 2.205	16 .630	120.9 4.760	M16 X 1.5 5/8-18UNF	32,100	24,100
95 3 3/4	UCS319D1 UCS319-312D1	200 7.8740	103 4.055	51 2.008	4 .157	41 1.614	62 2.441	16 .630	127.5 5.020	M16 X 1.5 5/8-18UNF	34,400	26,800
100 3 15/16 4	UCS320D1 UCS320-315D1 UCS320-400D1	215 8.4646	108 4.252	55 2.165	4 .157	42 1.654	66 2.598	18 .709	135.6 5.339	M18 X 1.5 5/8-18UNF	38,900	31,700
105	UCS321D1	225	112	57	4	44	68	18	142.1	M18 X 1.5	41,400	34,400
110	UCS322D1	240	117	59	4	46	71	18	151.7	M18 X 1.5	46,100	40,200
120	UCS324D1	260	126	63	4	51	75	18	165.2	M18 X 1.5	46,500	41,600
130	UCS326D1	280	135	67	5	54	81	20	178.3	M20 X 1.5	51,500	48,100
140	UCS328D1	300	145	71	5	59	86	20	190.4	M20 X 1.5	56,900	55,300

BALL BEARING INSERTS

Bore d	Bearing Number	Nominal Dimensions									Socket Set Screw ds	Basic Load Ratings (lbs)	
		D	L	Bi	Be	r	n	m	G	Di		Dynamic C	Static C ₀
20 ¾	UEL204D1 UEL204-012D1	47 1.8504	43.7 1.720	34.2 1.346	18 .709	1.5 .059	17.1 .672	26.6 1.047	4.8 .189	33 1.31	M6 X 0.75 ¼-28UNF	2,890	1,500
25 1⅜ 7/8 1⅝ 1	UEL205D1 UEL205-013D1 UEL205-014D1 UEL205-015D1 UEL205-100D1	52 2.0472	44.4 1.748	34.9 1.374	18 .709	1.5 .059	17.5 .688	26.9 1.059	4.8 .189	38 1.50	M6 X 0.75 ¼-28UNF	3,150	1,760
30 1 ⅛ 1 ½ 1 ¾ 1 ¼	UEL206D1 UEL206-101D1 UEL206-102D1 UEL206-103D1 UEL206-104D1	62 2.4409	48.4 1.906	36.5 1.437	20 .787	1.5 .059	18.3 .719	30.1 1.185	6 .236	44.5 1.75	M8 X 1 5/16-24UNF	4,400	2,540
35 1 ¼ 1 ⅝ 1 ¾ 1 7/8	UEL207D1 UEL207-104D1 UEL207-105D1 UEL207-106D1 UEL207-107D1	72 2.8346	51.1 2.012	37.6 1.480	22 .866	2 .079	18.8 .742	32.3 1.272	6.8 .268	55.5 2.19	M10 X 1.25 ¾-24UNF	5,750	3,440
40 1 ½ 1 ⅝	UEL208D1 UEL208-108D1 UEL208-109D1	80 3.1496	56.3 2.217	42.8 1.685	24 .945	2 .079	21.4 .844	34.9 1.374	6.8 .268	60 2.37	M10 X 1.25 ¾-24UNF	6,550	4,000
45 1 ⅝ 1 11/16 1 ¾	UEL209D1 UEL209-110D1 UEL209-111D1 UEL209-112D1	85 3.3465	56.3 2.217	42.8 1.685	24 .945	2 .079	21.4 .844	34.9 1.374	6.8 .268	63.5 2.50	M10 X 1.25 ¾-24UNF	7,350	4,590
50 1 13/16 1 7/8 1 15/16 2	UEL210D1 UEL210-113D1 UEL210-114D1 UEL210-115D1 UEL210-200D1	90 3.5433	62.7 2.469	49.2 1.937	25 .984	2 .079	24.6 .969	38.1 1.500	6.8 .268	69.5 2.74	M10 X 1.25 ¾-24UNF	7,900	5,220
55 2 2 1/16 2 1/8 2 3/16	UEL211D1 UEL211-200D1 UEL211-201D1 UEL211-202D1 UEL211-203D1	100 3.9370	71.4 2.811	55.5 2.185	27 1.063	2.5 .098	27.8 1.094	43.6 1.717	8 .315	76 3.00	M10 X 1.25 ¾-24UNF	9,750	6,560
60 2 ¼ 2 3/8 2 7/16	UEL212D1 UEL212-204D1 UEL212-206D1 UEL212-207D1	110 4.3307	77.8 3.063	61.9 2.437	30 1.181	2.5 .098	31 1.219	46.8 1.843	8 .315	84 3.31	M10 X 1.25 ¾-24UNF	11,800	8,100
65 2 ½	UEL213D1 UEL213-208D1	120 4.7244	85.7 3.374	68.3 2.689	32 1.260	2.5 .098	34.15 1.344	51.55 2.030	8.7 .343	97 3.819	M10 X 1.25 ¾-24UNF	12,900	9,000
70 2 11/16 2 ¾	UEL214D1 UEL214-211D1 UEL214-212D1	125 4.9213	85.7 3.374	68.3 2.689	33 1.299	2.5 .098	34.15 1.344	51.55 2.030	8.7 .343	97 3.819	M10 X 1.25 ¾-24UNF	13,900	9,900
75 2 15/16 3	UEL215D1 UEL215-215D1 UEL215-300D1	130 5.1181	92 3.622	74.6 2.937	34 1.339	2.5 .098	37.3 1.469	54.7 2.154	8.7 .343	102 4.016	M10 X 1.25 ¾-24UNF	14,800	11,100

Units: Millimeters
INCHES

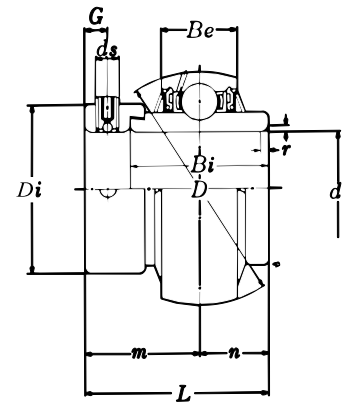
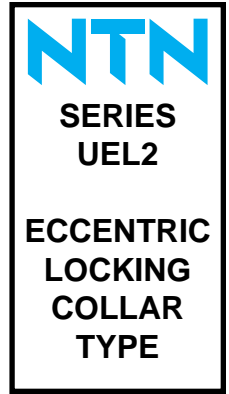

"A-" at front of part number to denote Ultraclass insert.

NTN
SERIES
UEL3
ECCENTRIC
LOCKING
COLLAR
TYPE

Units: **Millimeters**
INCHES

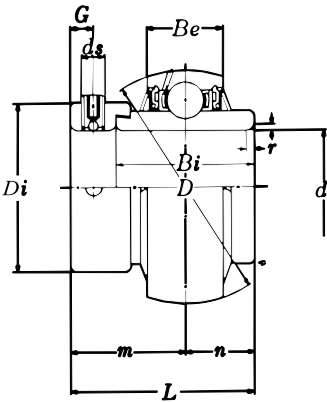

BALL BEARING INSERTS

Bore <i>d</i>	Bearing Number	Nominal Dimensions									Socket Set Screw <i>ds</i>	Basic Load Ratings (lbs)	
		<i>D</i>	<i>L</i>	<i>Bi</i>	<i>Be</i>	<i>r</i>	<i>n</i>	<i>m</i>	<i>G</i>	<i>Di</i>		<i>C</i>	<i>C₀</i>
25 7/8 15/16 1	UEL305D1 UEL305-014D1 UEL305-015D1 UEL305-100D1	62 2.4409	46.8 1.843	34.9 1.374	20 .787	2 .079	16.7 .657	30.1 1.185	6 .236	42.8 1.685	M8 X 1 5/16-24UNF	4,770	2,450
30 1 1/8 1 3/8	UEL306D1 UEL306-102D1 UEL306-103D1	72 2.8346	50 1.969	36.5 1.437	23 .906	2 .079	17.5 .689	32.5 1.280	6.7 .264	50 1.969	M8 X 1 5/16-24UNF	6,000	3,370
35 1 1/4 1 5/8 1 3/4 1 7/8	UEL307D1 UEL307-104D1 UEL307-105D1 UEL307-106D1 UEL307-107D1	80 3.1496	51.6 2.031	38.1 1.500	25 .984	2.5 .098	18.3 .720	33.3 1.311	6.7 .264	55 2.165	M8 X 1 5/16-24UNF	7,530	4,290
40 1 1/2	UEL308D1 UEL308-108D1	90 3.5433	57.1 2.248	41.3 1.626	27 1.063	2.5 .098	19.8 .780	37.3 1.469	8 .315	63.5 2.500	M10 X 1.25 3/8-24UNF	9,100	5,400
45 1 5/8 1 11/16 1 3/4	UEL309D1 UEL309-110D1 UEL309-111D1 UEL309-112D1	100 3.9370	58.7 2.311	42.9 1.689	29 1.142	2.5 .098	19.8 .780	38.9 1.531	8 .315	70 2.756	M10 X 1.25 3/8-24UNF	11,900	7,200
50 1 7/8 1 15/16	UEL310D1 UEL310-114D1 UEL310-115D1	110 4.3307	66.6 2.622	49.2 1.937	32 1.260	3 .118	24.6 .969	42 1.654	8.7 .343	76.2 3.000	M10 X 1.25 3/8-24UNF	13,900	8,660
55 2 2 1/8 2 3/8	UEL311D1 UEL311-200D1 UEL311-202D1 UEL311-203D1	120 4.7244	73 2.874	55.6 2.189	34 1.339	3 .118	27.8 1.094	45.2 1.780	8.7 .343	83 3.268	M10 X 1.25 3/8-24UNF	16,100	10,100
60 2 1/4 2 3/8 2 7/8	UEL312D1 UEL312-204D1 UEL312-206D1 UEL312-207D1	130 5.1181	79.4 3.126	61.9 2.437	36 1.417	3.5 .138	30.95 1.219	48.45 1.907	8.7 .343	89 3.504	M10 X 1.25 3/8-24UNF	18,400	11,700
65 2 1/2	UEL313D1 UEL313-208D1	140 5.5118	85.7 3.374	65.1 2.563	39 1.535	3.5 .138	32.55 1.281	53.15 2.093	10.3 .406	97 3.819	M12 X 1.5 1/2-20UNF	20,800	13,500
70 2 11/16 2 3/4	UEL314D1 UEL314-211D1 UEL314-212D1	150 5.9055	92.1 3.626	68.3 2.689	41 1.614	3.5 .138	34.15 1.344	57.95 2.281	10.3 .406	102 4.016	M12 X 1.5 1/2-20UNF	23,400	15,300
75 2 15/16 3	UEL315D1 UEL315-215D1 UEL315-300D1	160 6.2992	100 3.937	74.6 2.937	43 1.693	3.5 .138	37.3 1.469	62.7 2.469	12.7 .500	113 4.449	M16 X 1.5 5/8-18UNF	25,400	17,300
80 3 1/8 3 3/8	UEL316D1 UEL316-302D1 UEL316-303D1	170 6.6929	106.4 4.189	81 3.189	45 1.772	3.5 .138	40.5 1.594	65.9 2.594	12.7 .500	119 4.685	M16 X 1.5 5/8-18UNF	27,700	19,400
85 3 1/4	UEL317D1 UEL317-304D1	180 7.0866	109.5 4.311	84.1 3.311	47 1.850	4 .157	42.05 1.656	67.45 2.656	12.7 .500	127 5.000	M16 X 1.5 5/8-18UNF	29,900	21,800
90 3 7/16 3 1/2	UEL318D1 UEL318-307D1 UEL318-308D1	190 7.4803	115.9 4.563	87.3 3.437	49 1.929	4 .157	43.65 1.719	72.25 2.844	14.3 .563	133 5.236	M20 X 1.5 3/4-16UNF	32,100	24,100
95 3 3/4	UEL319D1 UEL319-312D1	200 7.8740	122.3 4.815	93.7 3.689	51 2.008	4 .157	38.9 1.531	83.4 3.283	14.3 .563	140 5.512	M20 X 1.5 3/4-16UNF	34,400	26,800
100 3 15/16 4	UEL320D1 UEL320-315D1 UEL320-400D1	215 8.4646	128.6 5.063	100 3.937	55 2.165	4 .157	50 1.969	78.6 3.094	14.3 .563	146 5.748	M20 X 1.5 3/4-16UNF	38,900	31,700
105	UEL321D1	225	139.7	104.8	57	4	48.4	91.3	17.5	157	M20 X 1.5	41,400	34,400
110	UEL322D1	240	141.3	106.4	59	4	49.2	92.1	17.5	168	M20 X 1.5	46,100	40,200

"A-" at front of part number to denote Ultraclass insert.

BALL BEARING INSERTS – AEL2 SERIES

Units: Millimeters
INCHES



Bore <i>d</i>	Bearing Number	Nominal Dimensions										Socket Set Screw <i>ds</i>	Basic Load Ratings (lbs)	
		<i>D</i>	<i>L</i>	<i>Bi</i>	<i>Be</i>	<i>r</i>	<i>n</i>	<i>m</i>	<i>G</i>	<i>Di</i>	Dynamic <i>C</i>		Static <i>C₀</i>	
12 ½	AEL201	40	28.6	19	12	0.6	6.5	22.1	4.8	29	4.8	M6 X 0.75 ¼-28UNF	2,160	1,030
	AEL201-008	1.5748	1.126	.748	.472	.024	.256	.870	.189	1.14	1.14			
15 9/16 5/8	AEL202	40	28.6	19	12	0.6	6.5	22.1	4.8	29	4.8	M6 X 0.75 ¼-28UNF	2,160	1,030
	AEL202-009 AEL202-010	1.5748	1.126	.748	.472	.024	.256	.870	.189	1.14	1.14			
17 11/16	AEL203	40	28.6	19	12	0.6	6.5	22.1	4.8	29	4.8	M6 X 0.75 ¼-28UNF	2,160	1,030
	AEL203-011	1.5748	1.126	.748	.472	.024	.256	.870	.189	1.14	1.14			
20 ¾	AEL204	47	31	21.5	14	1	7.5	23.5	4.8	33	4.8	M6 X 0.75 ¼-28UNF	2,890	1,500
	AEL204-012	1.8504	1.219	.846	.551	.039	.295	.924	.189	1.31	1.31			
25 1 1/16 7/8 15/16 1	AEL205	52	31	21.5	15	1	7.5	23.5	4.8	38	4.8	M6 X 0.75 ¼-28UNF	3,150	1,760
	AEL205-013	2.0472	1.219	.846	.591	.039	.295	.924	.189	1.50	1.50			
	AEL205-014													
	AEL205-015													
AEL205-100														
30 1 1/8 1 1/16 1 3/8 1 1/4	AEL206	62	35.7	23.8	16	1	9	26.7	6	44.5	6	M8 X 1 5/16-24UNF	4,400	2,540
	AEL206-101	2.4409	1.406	.937	.630	.039	.354	1.052	.236	1.75	1.75			
	AEL206-102													
	AEL206-103													
AEL206-104														
35 1 1/4 1 5/16 1 3/8 1 7/16	AEL207	72	38.9	25.4	17	1.5	9.5	29.4	6.8	55.5	6.8	M10 X 1.25 ¾-24UNF	5,750	3,440
	AEL207-104	2.8346	1.531	1.000	.669	.059	.374	1.157	.268	2.19	2.19			
	AEL207-105													
	AEL207-106													
AEL207-107														
40 1 1/2 1 9/16	AEL208	80	43.7	30.2	18	1.5	11	32.7	6.8	60	6.8	M10 X 1.25 ¾-24UNF	6,550	4,000
	AEL208-108 AEL208-109	3.1496	1.719	1.189	.709	.059	.433	1.286	.268	2.37	2.37			
45 1 5/8 1 11/16	AEL209	85	43.7	30.2	19	1.5	11	32.7	6.8	63.5	6.8	M10 X 1.25 ¾-24UNF	7,350	4,600
	AEL209-110 AEL209-111	3.4640	1.720	1.189	.748	.059	.433	1.287	.268	2.50	2.50			
50 1 13/16 1 7/8 1 15/16 2	AEL210W3	90	43.7	30.2	20	1.5	11	32.7	6.8	69.5	6.8	M10 X 1.25 ¾-24UNF	7,900	5,200
	AEL210-113	3.5433	1.720	1.189	.787	.059	.433	1.287	.268	2.736	2.736			
	AEL210-114													
	AEL210-115													
AEL210-200														
55 2	AEL211	100	48.4	32.5	21	2	12	36.4	8	76	8	M10 X 1.25 ¾-24UNF	9,750	6,550
	AEL211-200	3.937	1.906	1.280	.827	.079	.472	1.433	.315	2.992	2.992			

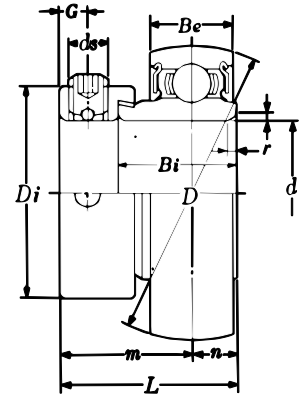

AEL2

BALL BEARING INSERTS – AELS2 SERIES

Bore <i>d</i>	Bearing Number	Nominal Dimensions												Socket Set Screw <i>ds</i>	Basic Load Ratings (lbs)	
		<i>D</i>	<i>L</i>	<i>Bi</i>	<i>Be</i>	<i>r</i>	<i>n</i>	<i>m</i>	<i>G</i>	<i>Di</i>	<i>Dn</i>	<i>an</i>	<i>bn</i>		Dynamic <i>C</i>	Static <i>C₀</i>
12 ½	AELS201N	40	28.6	19	12	0.6	6.5	22.1	4.8	29	38.1	1.98	1.5	M6 X 0.75 ¼-28UNF	2,160	1,030
	AELS201-008N	1.5748	1.126	.748	.472	.024	.256	.870	.189	1.14	1.500	.078	.059			
15 9/16 5/8	AELS202N	40	28.6	19	12	0.6	6.5	22.1	4.8	29	38.1	1.98	1.5	M6 X 0.75 ¼-28UNF	2,160	1,030
	AELS202-009N AELS202-010N	1.5748	1.126	.748	.472	.024	.256	.870	.189	1.14	1.500	.078	.059			
17 11/16	AELS203N	40	28.6	19	12	0.6	6.5	22.1	4.8	29	38.1	1.98	1.5	M6 X 0.75 ¼-28UNF	2,160	1,030
	AELS203-011N	1.5748	1.126	.748	.472	.024	.256	.870	.189	1.14	1.500	.078	.059			
20 ¾	AELS204N	47	31	21.5	14	1	7.5	23.5	4.8	33	44.6	2.38	1.5	M6 X 0.75 ¼-28UNF	2,890	1,500
	AELS204-012N	1.8504	1.219	.846	.551	.039	.295	.924	.189	1.31	1.756	.094	.059			
25 1 1/16 7/8 15/16 1	AELS205N	52	31	21.5	15	1	7.5	23.5	4.8	38	49.7	2.38	1.5	M6 X 0.75 ¼-28UNF	3,150	1,760
	AELS205-013N	2.0472	1.219	.846	.591	.039	.295	.924	.189	1.50	1.958	.094	.059			
	AELS205-014N															
	AELS205-015N															
AELS205-100N																
30 1 1/8 1 1/16 1 3/8 1 1/4	AELS206N	62	35.7	23.8	16	1	9	26.7	6	44.5	59.6	3.18	2.05	M8 X 1 5/16-24UNF	4,400	2,540
	AELS206-101N	2.4409	1.406	.937	.630	.039	.354	1.052	.236	1.75	2.347	.125	.081			
	AELS206-102N															
	AELS206-103N															
AELS206-104N																
35 1 1/4 1 5/16 1 3/8 1 7/16	AELS207N	72	38.9	25.4	17	1.5	9.5	29.4	6.8	55.5	68.8	3.18	2.05	M10 X 1.25 ¾-24UNF	5,750	3,440
	AELS207-104N	2.8346	1.531	1.000	.669	.059	.374	1.157	.268	2.19	2.709	.125	.081			
	AELS207-105N															
	AELS207-106N															
AELS207-107N																
40 1 1/2 1 9/16	AELS208N	80	43.7	30.2	18	1.5	11	32.7	6.8	60	76.8	3.18	2.05	M10 X 1.25 ¾-24UNF	6,550	4,000
	AELS208-108N AELS208-109N	3.1496	1.719	1.189	.709	.059	.433	1.286	.268	2.37	3.024	.125	.081			
45 1 5/8 1 11/16 1 3/4	AELS209N	85	43.7	30.2	19	1.5	11	32.7	6.8	63.5	81.8	3.18	2.05	M10 X 1.25 ¾-24UNF	7,350	4,600
	AELS209-110N AELS209-111N AELS209-112N	3.4645	1.720	1.189	.748	.059	.433	1.286	.268	2.50	3.221	.125	.081			
50 1 13/16 1 7/8 1 15/16 2	AELS210N	90	43.7	30.2	20	2.0	1.5	32.7	6.8	69.5	86.7	3.18	2.85	M10 X 1.25 ¾-24UNF	7,900	5,200
	AELS210-113N	3.5433	1.720	1.189	.787	.079	.059	1.286	.268	2.73	3.417	.125	.112			
	AELS210-114N															
	AELS210-115N															
AELS210-200N																
55 2	AELS211N	100	48.4	32.5	21	2.3	2.3	36.4	8.0	76.0	96.8	3.18	2.85	M10 X 1.25 ¾-24UNF	9,750	6,550
	AELS211-200N	3.9370	1.906	1.279	.826	.091	.091	1.433	.315	2.992	3.811	.125	.112			

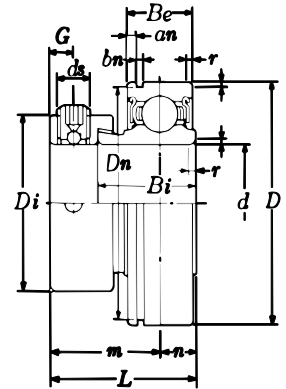

AELS2

NTN
SERIES
JEL2
ECCENTRIC
LOCKING
COLLAR
TYPE

Units: **Millimeters**
INCHES

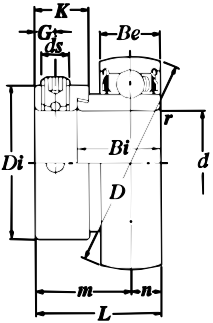

BALL BEARING INSERTS

Bore <i>d</i>	Bearing Number	Nominal Dimensions										Socket Set Screw <i>ds</i>	Basic Load Ratings (lbs)	
		<i>D</i>	<i>L</i>	<i>Bi</i>	<i>Be</i>	<i>r</i>	<i>n</i>	<i>m</i>	<i>G</i>	<i>Di</i>	Dynamic <i>C</i>		Static <i>C₀</i>	
12 ½	JEL201 JEL201-008	40 1.5748	28.6 1.126	19 .748	13 .512	1 .039	6.5 .256	22.1 .870	4.8 .189	29 1.142	M6 X 0.75 ¼-28UNF	2,160	1,030	
15 9/16 5/8	JEL202 JEL202-009 JEL202-010	40 1.5748	28.6 1.126	19 .748	13 .512	1 .039	6.5 .256	22.1 .870	4.8 .189	29 1.142	M6 X 0.75 ¼-28UNF	2,160	1,030	
17 11/16	JEL203 JEL203-011	40 1.5748	28.6 1.126	19 .748	13 .512	1 .039	6.5 .256	22.1 .870	4.8 .189	29 1.142	M6 X 0.75 ¼-28UNF	2,160	1,030	
20 ¾	JEL204 JEL204-012	47 1.8504	31.0 1.220	21.5 .846	15 .591	1.5 .059	7.5 .295	23.5 .925	4.8 .189	33 1.299	M6 X 0.75 ¼-28UNF	2,890	1,500	
25 13/16 7/8 15/16 1	JEL205 JEL205-013 JEL205-014 JEL205-015 JEL205-100	52 2.0472	31.0 1.220	21.5 .846	15 .591	1.5 .059	7.5 .295	23.5 .925	4.8 .189	38 1.496	M6 X 0.75 ¼-28UNF	3,150	1,770	
30 1 1/16 1 1/8 1 3/16 1 1/4	JEL206 JEL206-101 JEL206-102 JEL206-103 JEL206-104	62 2.4409	35.7 1.406	23.8 .937	18 .709	1.5 .059	9 .354	26.7 1.051	6 .236	44.5 1.752	M8 X 1 5/16-24UNF	4,400	2,540	
35 1 1/4 1 5/16 1 3/8 1 7/16	JEL207 JEL207-104 JEL207-105 JEL207-106 JEL207-107	72 2.8346	38.9 1.531	25.4 1.000	19 .748	2 .079	9.5 .374	29.4 1.157	6.8 .268	55.5 2.185	M10 X 1.25 3/8-24UNF	5,750	3,450	
40 1 1/2 1 9/16	JEL208 JEL208-108 JEL208-109	80 3.1496	43.7 1.720	30.2 1.189	22 .866	2 .079	11 .433	32.7 1.287	6.8 .268	60 2.362	M10 X 1.25 3/8-24UNF	6,550	4,000	
45 1 1/16 1 11/16 1 3/4	JEL209 JEL209-110 JEL209-111 JEL209-112	85 3.3465	43.7 1.720	30.2 1.189	22 .866	2 .079	11 .433	32.7 1.287	6.8 .268	63.5 2.50	M10 X 1.25 3/8-24UNF	7,380	4,580	
50 1 7/8 1 15/16	JEL210 JEL210-114 JEL210-115	90 3.5433	43.7 1.720	30.2 1.189	22 .866	2 .079	11 .433	32.7 1.287	6.8 .268	69.5 2.74	M10 X 1.25 3/8-24UNF	7,930	5,220	
55 2 2 3/16	JEL211 JEL211-200 JEL211-203	100 3.9370	48.4 1.906	32.5 1.280	24 .945	2.5 .098	12 .472	36.4 1.433	8 .315	76 3.00	M10 X 1.25 3/8-24UNF	9,810	6,570	
60 2 1/4	JEL212 JEL212-204	110 4.3307	53.1 2.091	37.2 1.465	27 1.063	2.5 .098	13.5 .531	39.6 1.559	8 .315	84 3.31	M10 X 1.25 3/8-24UNF	11,800	8,150	

BALL BEARING INSERTS

Units: **Millimeters**
INCHES



Bore <i>d</i>	Bearing Number	Nominal Dimensions										Socket Set Screw <i>ds</i>	Basic Load Ratings (lbs)	
		<i>D</i>	<i>L</i>	<i>Bi</i>	<i>Be</i>	<i>r</i>	<i>n</i>	<i>m</i>	<i>G</i>	<i>Di</i>	Dynamic <i>C</i>		Static <i>C₀</i>	
20 ¾	REL204 REL204-012	47 1.8504	43.7 1.720	34.2 1.3465	15 .591	1.5 .059	17.1 .673	26.6 1.047	4.8 .189	33 1.31	M6 X 0.75 ¼-28UNF	2,890	1,500	
25 1 3/16 7/8 1 5/16 1	REL205 REL205-013 REL205-014 REL205-015 REL205-100	52 2.0472	44.4 1.748	34.9 1.3740	15 .591	1.5 .059	17.45 .687	26.9 1.061	4.8 .189	38 1.50	M6 X 0.75 ¼-28UNF	3,150	1,770	
30 1 1/16 1 1/8 1 3/16 1 1/4	REL206 REL206-101 REL206-102 REL206-103 REL206-104	62 2.4409	48.4 1.906	36.5 1.4370	18 .709	1.5 .059	18.25 .719	30.2 1.188	6 .236	44.5 1.75	M8 X 1 5/16-24UNF	4,400	2,540	
35 1 1/4 1 5/16 1 3/8 1 7/16	REL207 REL207-104 REL207-105 REL207-106 REL207-107	72 2.8346	51.1 2.012	37.6 1.4803	19 .748	2 .079	18.8 .740	32.3 1.272	6.8 .268	55.5 2.19	M10 X 1.25 3/8-28UNF	5,750	3,450	
40 1 1/2 1 9/16	REL208 REL208-108 REL208-109	80 3.1496	56.3 2.217	42.8 1.6850	22 .866	2 .079	21.4 .843	34.9 1.375	6.8 .268	60 2.37	M10 X 1.25 3/8-28UNF	6,550	4,000	
45 1 5/8 1 11/16 1 3/4	REL209 REL209-110 REL209-111 REL209-112	85 3.3465	56.3 2.217	42.8 1.6850	22 .866	2 .079	21.4 .843	34.9 1.375	6.8 .268	63.5 2.50	M10 X 1.25 3/8-28UNF	7,350	4,600	
50 1 13/16 1 7/8 1 15/16 2	REL210 REL210-113 REL210-114 REL210-115 REL210-200	90 3.5433	62.7 2.469	49.2 1.9370	22 .866	2 .079	24.6 .969	38.1 1.501	6.8 .268	69.5 2.74	M10 X 1.25 3/8-28UNF	7,900	5,200	
55 2 2 1/16 2 1/8 2 3/16	REL211 REL211-200 REL211-201 REL211-202 REL211-203	100 3.9370	71.4 2.811	55.5 2.1850	24 .945	2.5 .098	27.75 1.093	43.7 1.719	8 .315	76 3.00	M10 X 1.25 3/8-28UNF	9,750	6,550	
60 2 1/4 2 5/16 2 3/8 2 7/16	REL212 REL212-204 REL212-205 REL212-206 REL212-207	110 4.3307	77.8 3.063	61.9 2.4370	27 1.063	2.5 .098	30.95 1.219	46.9 1.845	8 .315	84 3.31	M10 X 1.25 3/8-28UNF	11,800	8,150	

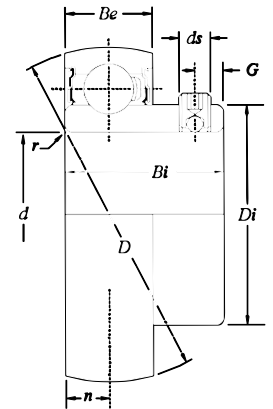

NTN
SERIES
UK2
ADAPTER
TYPE

Units: **Millimeters**
INCHES

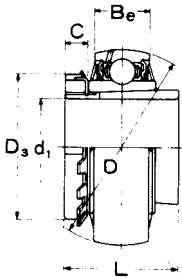
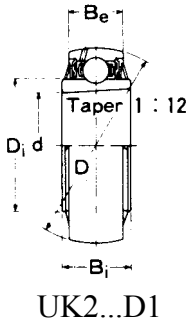

BALL BEARING INSERTS

Bore <i>d</i> ₁	Bearing and adapter number	Nominal dimensions								Basic Load Ratings (lbs)	
		<i>d</i>	<i>D</i>	<i>B</i> _i	<i>B</i> _e	<i>D</i> _i	<i>L</i>	<i>C</i>	<i>D</i> ₃	Dynamic <i>C</i>	Static <i>C</i> ₀
20	UK205D1 ; H 2305X	25	52	23	18	33.9	35	8	38	3,150	1,770
3/4	UK205D1 ; HE2305	0.9843	2.0472	0.906	0.709	1.335	1.378	0.315	1.496		
25	UK206D1 ; H 2306X	30	62	26	20	40.8	38	8	45	4,400	2,540
7/8	UK206D1 ; HS2306	1.1811	2.4409	1.024	0.787	1.606	1.496	0.315	1.772		
1	UK206D1 ; HE2306X										
30	UK207D1 ; H 2307X	35	72	29	22	46.8	43	9	52	5,750	3,450
1 1/8	UK207D1 ; HS2307	1.3780	2.8346	1.142	0.866	1.843	1.693	0.354	2.047		
35	UK208D1 ; H 2308X	40	80	31	24	53	46	10	58	6,550	4,000
1 1/4	UK208D1 ; HE2308X	1.5748	3.1496	1.220	0.945	2.087	1.811	0.394	2.283		
1 3/8	UK208D1 ; HS2308X										
40	UK209D1 ; H 2309X	45	85	31	24	57.5	50	11	65	7,350	4,600
1 7/16	UK209D1 ; HA2309	1.7717	3.3465	1.220	0.945	2.264	1.969	0.433	2.559		
1 1/2	UK209D1 ; HE2309X										
1 5/8	UK209D1 ; HS2309X										
45	UK210D1 ; H 2310X	50	90	32	25	62.4	55	12	70	7,900	5,200
1 5/8	UK210D1 ; HS2310	1.9685	3.5433	1.260	0.984	2.457	2.165	0.472	2.756		
1 11/16	UK210D1 ; HA2310										
1 3/4	UK210D1 ; HE2310X										
50	UK211D1 ; H 2311X	55	100	35	27	69	59	12	75	9,750	6,550
1 7/8	UK211D1 ; HS2311	2.1654	3.937	1.378	1.063	2.717	2.323	0.472	2.953		
1 15/16	UK211D1 ; HA2311										
2	UK211D1 ; HE2311XY										
55	UK212D1 ; H 2312X	60	110	38	30	77	62	13	80	11,800	8,150
2 1/8	UK212D1 ; HS2312X	2.3622	4.3307	1.496	1.181	3.031	2.441	0.512	3.150		
60	UK213D1 ; H 2313X	65	120	40	32	82.5	65	14	85	12,900	9,000
2 3/16	UK213D1 ; HA2313	2.5591	7.7244	1.575	1.260	3.248	2.559	0.551	3.346		
2 1/4	UK213D1 ; HE2313										
2 3/8	UK213D1 ; HS2313										
65	UK215D1 ; H 2315X	75	130	44	34	93	73	15	98	14,900	11,100
2 7/16	UK215D1 ; HA2315	2.9528	5.1181	1.732	1.339	3.661	2.874	0.591	3.858		
2 1/2	UK215D1 ; HE2315										
70	UK216D1 ; H 2316X	80	140	45	35	98.1	78	17	105	16,300	11,900
2 11/16	UK216D1 ; HA2316	3.1496	5.5118	1.772	1.378	3.862	3.071	0.669	4.134		
2 3/4	UK216D1 ; HE2316										
75	UK217D1 ; H 2317X	85	150	50	36	106.1	82	18	110	18,700	14,300
2 15/16	UK217D1 ; HA2317	3.3465	5.9055	1.9685	1.417	4.177	3.228	0.709	4.331		
3	UK217D1 ; HE2317										
80	UK218D1 ; H 2318X	90	160	60	37	111.6	86	18	120	21,600	16,100
3 3/16	UK218D1 ; HA2318	3.5433	6.2992	2.3622	1.457	4.394	3.386	0.709	4.724		

These numbers indicate re-lubricatable type. If maintenance free type is needed, please order without suffix "D1".

Adapter number with suffix "X" means a narrow slot type adapter sleeve. In this case the lock washer with the straight inner prong should be used.

For HE2311XY, screw thread pitch different from the standard is applied, because of the thin thread section of sleeve. To distinguish it, a suffix "Y" is added.

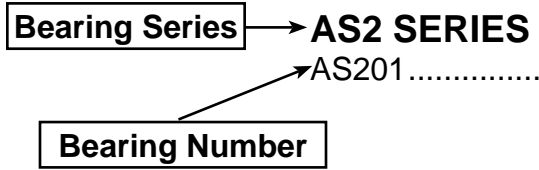

BALL BEARING INSERTS **LBS.**

AS2 SERIES	AEL206-101.....	.74	JEL210.....	1.86	UK213D1: HE2313.....	4.70
AS201.....	AEL206-102.....	.73	JEL210-114.....	1.99	UK213D1: HS2313.....	4.38
AS201-008.....	AEL206-103.....	.66	JEL210-115.....	1.91	UK215D1: H2315X.....	5.64
AS202.....	AEL206-104.....	.61	JEL211.....	2.51	UK215D1: HA2315.....	6.04
AS202-009.....	AEL207.....	1.08	JEL211-200.....	2.78	UK215D1: HE2315.....	5.84
AS202-010.....	AEL207-104.....	1.15	JEL211-203.....	2.47	UK216D1: H2316X.....	7.12
AS203.....	AEL207-105.....	1.10	JEL212.....	3.48	UK216D1: HA2316.....	7.38
AS203-011.....	AEL207-106.....	1.04	JEL212-204.....	3.70	UK216D1: HE2316.....	7.14
AS204.....	AEL207-107.....	.98	AR SERIES		UK217D1: H2317X.....	8.66
AS204-012.....	AEL208.....	1.46	AR201.....	.23	UK217D1: HA2317.....	8.73
AS205.....	AEL208-108.....	1.41	AR201-008.....	.22	UK217D1: HE2317.....	8.46
AS205-013.....	AEL208-109.....	1.34	AR202.....	.21	UK218D1: H2318X.....	10.45
AS205-014.....	AELS2 SERIES		AR202-009.....	.21	UK218D1: HA2318.....	11.00
AS205-015.....	AELS201N.....	.26	AR202-010.....	.20	REL SERIES	
AS205-100.....	AELS201-008N.....	.26	AR203.....	.19	REL204.....	.35
AS206.....	AELS202N.....	.24	AR203-011.....	.19	REL204-012.....	.38
AS206-101.....	AELS202-009N.....	.26	AR204.....	.31	REL205.....	.40
AS206-102.....	AELS202-010N.....	.24	AR204-012.....	.33	REL205-013.....	.49
AS206-103.....	AELS203N.....	.22	AR205.....	.35	REL205-014.....	.46
AS206-104.....	AELS203-011N.....	.23	AR205-013.....	.42	REL205-015.....	.42
AS207.....	AELS204N.....	.37	AR205-014.....	.40	REL205-100.....	.38
AS207-104.....	AELS204-012N.....	.35	AR205-015.....	.38	REL206.....	.66
AS207-105.....	AELS205N.....	.44	AR205-100.....	.33	REL206-101.....	.75
AS207-106.....	AELS205-013N.....	.51	AR206.....	.60	REL206-102.....	.71
AS207-107.....	AELS205-014N.....	.48	AR206-101.....	.66	REL206-103.....	.66
AS208.....	AELS205-015N.....	.45	AR206-102.....	.64	REL206-104.....	.60
AS208-108.....	AELS205-100N.....	.42	AR206-103.....	.60	REL207.....	.93
AS208-109.....	AELS206N.....	.68	AR206-104.....	.55	REL207-104.....	1.04
ASS2 SERIES	AELS206-101N.....	.74	AR207.....	.88	REL207-105.....	.99
ASS201N.....	AELS206-102N.....	.73	AR207-104.....	.99	REL207-106.....	.93
ASS201-008N.....	AELS206-103N.....	.66	AR207-105.....	.93	REL207-107.....	.88
ASS202N.....	AELS206-104N.....	.61	AR207-106.....	.88	REL208.....	1.28
ASS202-009N.....	AELS207N.....	1.08	AR207-107.....	.84	REL208-108.....	1.37
ASS202-010N.....	AELS207-104N.....	1.15	AR208.....	1.24	REL208-109.....	1.30
ASS203N.....	AELS207-105N.....	1.10	AR208-108.....	1.32	REL209.....	1.37
ASS203-011N.....	AELS207-106N.....	1.04	AR208-109.....	1.26	REL209-110.....	1.54
ASS204N.....	AELS207-107N.....	.98	AR209.....	1.35	REL209-111.....	1.54
ASS204-012N.....	AELS208N.....	1.46	AR209-110.....	1.52	REL209-112.....	1.39
ASS205N.....	AELS208-108N.....	1.41	AR209-111.....	1.46	REL210.....	1.61
ASS205-013N.....	AELS208-109N.....	1.34	AR209-112.....	1.37	REL210-113.....	1.85
ASS205-014N.....	JEL2 SERIES		AR210.....	1.48	REL210-114.....	1.76
ASS205-015N.....	JEL201.....	.26	AR210-113.....	1.70	REL210-115.....	1.65
ASS205-100N.....	JEL201-008.....	.25	AR210-114.....	1.61	REL210-200.....	1.57
ASS206N.....	JEL202.....	.22	AR210-115.....	1.52	REL211.....	2.25
ASS206-101N.....	JEL202-009.....	.24	AR210-200.....	1.43	REL211-200.....	2.58
ASS206-102N.....	JEL202-010.....	.22	UK2 SERIES		REL211-201.....	2.47
ASS206-103N.....	JEL203.....	.20	UK205D1: H2305X.....	.55	REL211-202.....	2.34
ASS206-104N.....	JEL203-011.....	.20	UK205D1: HE2305.....	.57	REL211-203.....	2.21
ASS207N.....	JEL204.....	.35	UK206D1: H2306X.....	.79	REL212.....	3.13
ASS207-104N.....	JEL204-012.....	.37	UK206D1: HS2306.....	.86	REL212-204.....	3.42
ASS207-105N.....	JEL205.....	.42	UK206D1: HE2306X.....	.78	REL212-205.....	3.26
ASS207-106N.....	JEL205-013.....	.50	UK207D1: H2307X.....	1.27	REL212-206.....	3.11
ASS207-107N.....	JEL205-014.....	.47	UK207D1: HS2307.....	1.30	REL212-207.....	2.93
ASS208N.....	JEL205-015.....	.44	UK208D1: H2308X.....	1.63	UC2 SERIES	
ASS208-108N.....	JEL205-100.....	.41	UK208D1: HE2308X.....	1.77	UC201D1.....	.46
ASS208-109N.....	JEL206.....	.71	UK208D1: HS2308X.....	1.63	UC201-008D1.....	.46
AEL2 SERIES	JEL206-101.....	.78	UK209D1: H2309X.....	1.83	UC202D1.....	.44
AEL201.....	JEL206-102.....	.73	UK209D1: HA2309.....	2.01	UC202-009D1.....	.44
AEL201-008.....	JEL206-103.....	.69	UK209D1: HE2309X.....	1.93	UC202-010D1.....	.42
AEL202.....	JEL206-104.....	.64	UK209D1: HS2309X.....	1.76	UC203D1.....	.40
AEL202-009.....	JEL207.....	1.10	UK210D1: H2310X.....	2.14	UC203-011D1.....	.39
AEL202-010.....	JEL207-104.....	1.22	UK210D1: HS2310.....	2.38	UC204D1.....	.37
AEL203.....	JEL207-105.....	1.16	UK210D1: HA2310.....	2.28	UC204-012D1.....	.39
AEL203-011.....	JEL207-106.....	1.11	UK210D1: HE2310X.....	2.18	UC205D1.....	.44
AEL204.....	JEL207-107.....	1.05	UK211D1: H2311X.....	2.78	UC205-013D1.....	.53
AEL204-012.....	JEL208.....	1.43	UK211D1: HS2311.....	2.96	UC205-014D1.....	.51
AEL205.....	JEL208-108.....	1.53	UK211D1: HA2311.....	2.84	UC205-015D1.....	.46
AEL205-013.....	JEL208-109.....	1.46	UK211D1: HE2311XY.....	2.70	UC205-100D1.....	.44
AEL205-014.....	JEL209.....	1.69	UK212D1: H2312X.....	3.51	UC206D1.....	.73
AEL205-015.....	JEL209-110.....	1.87	UK212D1: HS2312.....	3.60	UC206-101D1.....	.82
AEL205-100.....	JEL209-111.....	1.79	UK213D1: H2313X.....	4.41	UC206-102D1.....	.77
AEL206.....	JEL209-112.....	1.72	UK213D1: HA2313X.....	4.86	UC206-103D1.....	.73



Bearing Series → **AS2 SERIES**

Bearing Number → AS20122 ← Weight (lbs)

Bearing Number

Weight (lbs)

BALL BEARING INSERTS **LBS.**

UC206-104D1.....	.66	UCX13-208D1.....	5.60	UC320-400D1.....	23.4	UCS309D1.....	2.93
UC207D1.....	1.08	UCX13-209D1.....	5.38	UC321D1.....	26.9	UCS309-110D1.....	3.17
UC207-104D1.....	1.21	UCX14D1.....	5.45	UC322D1.....	31.5	UCS309-111D1.....	3.09
UC207-105D1.....	1.15	UCX14-210D1.....	5.93	UC324D1.....	40.8	UCS309-112D1.....	2.98
UC207-106D1.....	1.08	UCX14-211D1.....	5.69	UC326D1.....	50.7	UCS310D1.....	3.79
UC207-107D1.....	1.01	UCX14-212D1.....	5.47	UC328D1.....	62.8	UCS310-114D1.....	3.99
UC208D1.....	1.43	UCX15D1.....	6.86	UCS2 SERIES		UCS310-115D1.....	3.85
UC208-108D1.....	1.52	UCX15-213D1.....	7.43	UCS201D1N.....	.46	UCS311D1.....	4.74
UC208-109D1.....	1.46	UCX15-214D1.....	7.19	UCS201-008D1N.....	.46	UCS311-200D1.....	5.14
UC209D1.....	1.54	UCX15-215D1.....	6.92	UCS202D1N.....	.44	UCS311-202D1.....	4.85
UC209-110D1.....	1.76	UCX15-300D1.....	6.66	UCS202-009D1N.....	.44	UCS311-203D1.....	4.68
UC209-111D1.....	1.68	UCX16D1.....	8.36	UCS202-010D1N.....	.42	UCS312D1.....	5.95
UC209-112D1.....	1.57	UCX16-302D1.....	8.47	UCS203D1N.....	.40	UCS312-204D1.....	6.27
UC210D1.....	1.76	UCX16-303D1.....	8.18	UCS203-011D1N.....	.39	UCS312-206D1.....	5.89
UC210-113D1.....	2.03	UCX17D1.....	10.6	UCS204D1N.....	.37	UCS312-207D1.....	5.72
UC210-114D1.....	1.92	UCX17-305D1.....	10.8	UCS204-012D1N.....	.39	UCS313D1.....	7.43
UC210-115D1.....	1.81	UCX17-307D1.....	10.1	UCS205D1N.....	.44	UCS313-208D1.....	7.63
UC210-200D1.....	1.69	UCX18D1.....	12.2	UCS205-013D1N.....	.53	UCS314D1.....	8.89
UC211D1.....	2.38	UCX18-308D1.....	12.4	UCS205-014D1N.....	.51	UCS314-211D1.....	9.13
UC211-200D1.....	2.71	UCX20D1.....	19.7	UCS205-015D1N.....	.46	UCS314-212D1.....	8.91
UC211-201D1.....	2.60	UCX20-314D1.....	18.4	UCS206D1N.....	.73	UCS315D1.....	10.8
UC211-202D1.....	2.46	UCX20-315D1.....	19.7	UCS206-101D1N.....	.82	UCS315-215D1.....	10.9
UC211-203D1.....	2.34	UCX20-400D1.....	19.2	UCS206-102D1N.....	.77	UCS315-300D1.....	10.6
UC212D1.....	3.37	UC3 SERIES		UCS206-103D1N.....	.73	UCS316D1.....	12.7
UC212-204D1.....	3.66	UC305D1.....	.77	UCS207D1N.....	1.08	UCS316-302D1.....	12.7
UC212-206D1.....	3.33	UC305-014D1.....	.77	UCS207-104D1N.....	1.21	UCS316-303D1.....	12.5
UC212-207D1.....	3.17	UC305-015D1.....	.77	UCS207-105D1N.....	1.15	UCS317D1.....	15.2
UC213D1.....	4.08	UC305-100D1.....	.77	UCS207-106D1N.....	1.08	UCS317-304D1.....	15.7
UC213-208D1.....	4.26	UC306D1.....	1.23	UCS207-107D1N.....	1.01	UCS318D1.....	17.2
UC214D1.....	4.63	UC306-102D1.....	1.23	UCS208D1N.....	1.43	UCS318-307D1.....	17.8
UC214-211D1.....	4.87	UC306-103D1.....	1.23	UCS208-108D1N.....	1.52	UCS318-308D1.....	17.4
UC214-212D1.....	4.65	UC307D1.....	1.57	UCS208-109D1N.....	1.46	UCS319D1.....	19.8
UC215D1.....	5.18	UC307-104D1.....	1.57	UCS209D1N.....	1.54	UCS319-312D1.....	19.7
UC215-215D1.....	5.25	UC307-105D1.....	1.57	UCS209-110D1N.....	1.76	UCS320D1.....	24.5
UC215-300D1.....	4.98	UC307-106D1.....	1.57	UCS209-111D1N.....	1.68	UCS320-315D1.....	24.5
UC216D1.....	6.17	UC307-107D1.....	1.57	UCS209-112D1N.....	1.57	UCS320-400D1.....	24.1
UC216-302D1.....	6.28	UC308D1.....	2.12	UCS210D1N.....	1.76	UCS321D1.....	27.8
UC217D1.....	7.43	UC308-108D1.....	2.12	UCS210-113D1N.....	2.03	UCS322D1.....	32.4
UC217-304D1.....	7.92	UC309D1.....	2.82	UCS210-114D1N.....	1.92	UCS324D1.....	41.9
UC218D1.....	9.61	UC309-110D1.....	2.82	UCS210-115D1N.....	1.81	UCS326D1.....	52.0
UC218-308D1.....	9.88	UC309-111D1.....	2.82	UCS211D1N.....	2.38	UCS328D1.....	64.4
UCX SERIES		UC309-112D1.....	2.82	UCS211-200D1N.....	2.71	UEL2 SERIES	
UCX05D1.....	.86	UC310D1.....	3.64	UCS211-201D1N.....	2.60	UEL204D1.....	.51
UCX05-013D1.....	.97	UC310-114D1.....	3.64	UCS211-202D1N.....	2.46	UEL204-012D1.....	.45
UCX05-014D1.....	.93	UC310-115D1.....	3.64	UCS211-203D1N.....	2.34	UEL205D1.....	.60
UCX05-015D1.....	.88	UC311D1.....	4.56	UCS212D1.....	3.51	UEL205-013D1.....	.61
UCX05-100D1.....	.84	UC311-200D1.....	4.56	UCS212-204D1.....	3.78	UEL205-014D1.....	.58
UCX06D1.....	1.50	UC311-202D1.....	4.56	UCS212-206D1.....	3.45	UEL205-015D1.....	.55
UCX06-101D1.....	1.61	UC311-203D1.....	4.56	UCS212-207D1.....	3.29	UEL205-100D1.....	.51
UCX06-102D1.....	1.54	UC312D1.....	5.73	UCS213D1.....	4.23	UEL206D1.....	.99
UCX06-103D1.....	1.50	UC312-204D1.....	5.73	UCS213-208D1.....	4.41	UEL206-101D1.....	.94
UCX07D12.....	1.81	UC312-206D1.....	5.73	UCS214D1.....	4.78	UEL206-102D1.....	.89
UCX07-105D1.....	1.87	UC312-207D1.....	5.73	UCS215D1.....	5.36	UEL206-103D1.....	.84
UCX07-106D1.....	1.81	UC313D1.....	7.17	UCS216D1.....	6.37	UEL206-104D1.....	.80
UCX07-107D1.....	1.74	UC313-208D1.....	7.17	UCS217D1.....	7.65	UEL207D1.....	1.32
UCX08D1.....	2.05	UC314D1.....	8.58	UCS218D1.....	9.83	UEL207-104D1.....	1.45
UCX08-108D1.....	2.16	UC314-211D1.....	8.58	UCS3 SERIES		UEL207-105D1.....	1.40
UCX08-109D1.....	2.07	UC314-212D1.....	8.58	UCS305D1.....	.82	UEL207-106D1.....	1.35
UCX09D1.....	2.21	UC315D1.....	10.4	UCS305-014D1.....	.90	UEL207-107D1.....	1.28
UCX09-110D1.....	2.43	UC315-215D1.....	10.4	UCS305-015D1.....	.83	UEL208D1.....	1.74
UCX09-111D1.....	2.34	UC315-300D1.....	10.4	UCS305-100D1.....	.81	UEL208-108D1.....	1.90
UCX09-112D1.....	2.25	UC316D1.....	12.2	UCS306D1.....	1.28	UEL208-109D1.....	1.82
UCX10D1.....	2.98	UC316-302D1.....	12.2	UCS306-102D1.....	1.33	UEL209D1.....	1.87
UCX10-114D1.....	3.15	UC316-303D1.....	12.2	UCS306-103D1.....	1.28	UEL209-110D1.....	2.05
UCX10-115D1.....	3.04	UC317D1.....	14.7	UCS307D1.....	1.63	UEL209-111D1.....	1.97
UCX11D1.....	4.19	UC317-304D1.....	14.7	UCS307-104D1.....	1.77	UEL209-112D1.....	1.88
UCX11-201D1.....	4.43	UC318D1.....	16.7	UCS307-105D1.....	1.70	UEL210D1.....	2.16
UCX11-202D1.....	4.30	UC318-307D1.....	16.7	UCS307-106D1.....	1.64	UEL210-113D1.....	2.46
UCX11-203D1.....	4.12	UC318-308D1.....	16.7	UCS307-107D1.....	1.57	UEL210-114D1.....	2.36
UCX12D1.....	5.01	UC319D1.....	19.2	UCS308D1.....	2.21	UEL210-115D1.....	2.25
UCX12-206D1.....	4.96	UC319-312D1.....	19.2	UCS308-108D1.....	2.32	UEL210-200D1.....	2.09
UCX12-207D1.....	4.81	UC320D1.....	23.8			UEL211D1.....	2.91
UCX13D1.....	5.40	UC320-315D1.....	23.8			UEL211-200D1.....	3.28



BALL BEARING INSERTS		LBS.
UEL211-201D1	3.12	
UEL211-202D1	3.02	
UEL211-203D1	2.90	
UEL212D1	4.12	
UEL212-204D1	4.38	
UEL212-206D1	4.05	
UEL212-207D1	3.88	
UEL3 SERIES		
UEL305D195	
UEL305-014D1	1.05	
UEL305-015D1	1.01	
UEL305-100D196	
UEL306D1	1.52	
UEL306-102D1	1.51	
UEL306-103D1	1.45	
UEL307D1	1.76	
UEL307-104D1	1.92	
UEL307-105D1	1.84	
UEL307-106D1	1.77	
UEL307-107D1	1.69	
UEL308D1	2.38	
UEL308-108D1	2.58	
UEL309D1	3.20	
UEL309-110D1	3.36	
UEL309-111D1	3.26	
UEL309-112D1	3.15	
UEL310D1	4.10	
UEL310-114D1	4.29	
UEL310-115D1	4.15	
UEL311D1	5.16	
UEL311-200D1	5.58	
UEL311-202D1	5.25	
UEL311-203D1	5.08	
UEL312D1	6.48	
UEL312-204D1	6.80	
UEL312-206D1	6.48	
UEL312-207D1	6.19	
UEL313D1	8.09	
UEL313-208D1	8.49	
UEL314D1	9.70	
UEL314-211D1	10.2	
UEL314-212D1	9.96	
UEL315D1	11.8	
UEL315-215D1	12.7	
UEL315-300D1	12.5	
UEL316D1	14.8	
UEL316-302D1	14.6	
UEL316-303D1	14.9	
UEL317D1	17.6	
UEL317-304D1	17.7	
UEL318D1	20.1	
UEL318-307D1	20.7	
UEL318-308D1	20.2	
UEL319D1	22.9	
UEL319-312D1	22.6	
UEL320D1	28.7	
UEL320-315D1	27.6	
UEL320-400D1	27.0	
UEL321D1	32.2	
UEL322D1	37.9	



Bearing Series → AS2 SERIES

AS201 11,000

Bearing Number

Speed Limit (RPMs)

BALL BEARING INSERTS				RPMs			
AS2 SERIES							
AS201.....	11,000	AEL206-101.....	4,900	JEL210.....	3,100	UK213D1: HE2313.....	2,400
AS201-008.....	11,000	AEL206-102.....	4,900	JEL210-114.....	3,100	UK213D1: HS2313.....	2,400
AS202.....	10,000	AEL206-103.....	4,900	JEL210-115.....	3,100	UK215D1: H2315X.....	2,100
AS202-009.....	10,000	AEL206-104.....	4,900	JEL211.....	2,900	UK215D1: HA2315.....	2,100
AS202-010.....	10,000	AEL207.....	4,200	JEL211-200.....	2,900	UK215D1: HE2315.....	2,100
AS203.....	8,000	AEL207-104.....	4,200	JEL211-203.....	2,900	UK216D1: H2316X.....	2,000
AS203-011.....	8,000	AEL207-105.....	4,200	JEL212.....	2,500	UK216D1: HA2316.....	2,000
AS204.....	6,700	AEL207-106.....	4,200	JEL212-204.....	2,500	UK216D1: HE2316.....	2,000
AS204-012.....	6,700	AEL207-107.....	4,200			UK217D1: H2317X.....	1,900
AS205.....	5,900	AEL208.....	3,700	AR SERIES		UK217D1: HA2317.....	1,900
AS205-013.....	5,900	AEL208-108.....	3,700	AR201.....	11,000	UK217D1: HE2317.....	1,900
AS205-014.....	5,900	AEL208-109.....	3,700	AR201-008.....	11,000	UK218D1: H2318X.....	1,700
AS205-015.....	5,900			AR202.....	10,000	UK218D1: HA2318.....	1,700
AS205-100.....	5,900	AELS2 SERIES		AR202-009.....	10,000		
AS206.....	4,900	AELS201N.....	11,000	AR202-010.....	10,000	REL SERIES	
AS206-101.....	4,900	AELS201-008N.....	11,000	AR203.....	8,000	REL204.....	6,700
AS206-102.....	4,900	AELS202N.....	10,000	AR203-011.....	8,000	REL204-012.....	6,700
AS206-103.....	4,900	AELS202-009N.....	10,000	AR204.....	6,700	REL205.....	5,900
AS206-104.....	4,900	AELS202-010N.....	10,000	AR204-012.....	6,700	REL205-013.....	5,900
AS207.....	4,200	AELS203N.....	8,000	AR205.....	5,900	REL205-014.....	5,900
AS207-104.....	4,200	AELS203-011N.....	8,000	AR205-013.....	5,900	REL205-015.....	5,900
AS207-105.....	4,200	AELS204N.....	6,700	AR205-014.....	5,900	REL205-100.....	5,900
AS207-106.....	4,200	AELS204-012N.....	6,700	AR205-015.....	5,900	REL206.....	4,900
AS207-107.....	4,200	AELS205N.....	5,900	AR205-100.....	5,900	REL206-101.....	4,900
AS208.....	3,700	AELS205-013N.....	5,900	AR206.....	4,900	REL206-102.....	4,900
AS208-108.....	3,700	AELS205-014N.....	5,900	AR206-101.....	4,900	REL206-103.....	4,900
AS208-109.....	3,700	AELS205-015N.....	5,900	AR206-102.....	4,900	REL206-104.....	4,900
		AELS205-100N.....	5,900	AR206-103.....	4,900	REL207.....	4,200
		AELS206N.....	4,900	AR206-104.....	4,900	REL207-104.....	4,200
ASS2 SERIES		AELS206-101N.....	4,900	AR207.....	4,200	REL207-105.....	4,200
ASS201N.....	11,000	AELS206-102N.....	4,900	AR207-104.....	4,200	REL207-106.....	4,200
ASS201-008N.....	11,000	AELS206-103N.....	4,900	AR207-105.....	4,200	REL207-107.....	4,200
ASS202N.....	10,000	AELS206-104N.....	4,900	AR207-106.....	4,200	REL208.....	3,700
ASS202-009N.....	10,000	AELS207N.....	4,200	AR207-107.....	4,200	REL208-108.....	3,700
ASS202-010N.....	10,000	AELS207-104N.....	4,200	AR208.....	3,700	REL208-109.....	3,700
ASS203N.....	8,000	AELS207-105N.....	4,200	AR208-108.....	3,700	REL209.....	3,500
ASS203-011N.....	8,000	AELS207-106N.....	4,200	AR208-109.....	3,700	REL209-110.....	3,500
ASS204N.....	6,700	AELS207-107N.....	4,200	AR209.....	3,500	REL209-111.....	3,500
ASS204-012N.....	6,700	AELS208N.....	3,700	AR209-110.....	3,500	REL209-112.....	3,500
ASS205N.....	5,900	AELS208-108N.....	3,700	AR209-111.....	3,500	REL210.....	3,100
ASS205-013N.....	5,900	AELS208-109N.....	3,700	AR209-112.....	3,500	REL210-113.....	3,100
ASS205-014N.....	5,900			AR210.....	3,100	REL210-114.....	3,100
ASS205-015N.....	5,900	JEL2 SERIES		AR210-113.....	3,100	REL210-115.....	3,100
ASS205-100N.....	5,900	JEL201.....	11,000	AR210-114.....	3,100	REL210-200.....	3,100
ASS206N.....	4,900	JEL201-008.....	11,000	AR210-115.....	3,100	REL211.....	2,900
ASS206-101N.....	4,900	JEL202.....	10,000	AR210-200.....	3,100	REL211-200.....	2,900
ASS206-102N.....	4,900	JEL202-009.....	10,000			REL211-201.....	2,900
ASS206-103N.....	4,900	JEL202-010.....	10,000	UK2 SERIES		REL211-202.....	2,900
ASS206-104N.....	4,900	JEL203.....	8,000	UK205D1: H2305X.....	5,900	REL211-203.....	2,900
ASS207N.....	4,200	JEL203-011.....	8,000	UK205D1: HE2305.....	5,900	REL212.....	2,500
ASS207-104N.....	4,200	JEL204.....	6,700	UK206D1: H2306X.....	4,900	REL212-204.....	2,500
ASS207-105N.....	4,200	JEL204-012.....	6,700	UK206D1: HS2306.....	4,900	REL212-205.....	2,500
ASS207-106N.....	4,200	JEL205.....	5,900	UK206D1: HE2306X.....	4,900	REL212-206.....	2,500
ASS207-107N.....	4,200	JEL205-013.....	5,900	UK207D1: H2307X.....	4,200	REL212-207.....	2,500
ASS208N.....	3,700	JEL205-014.....	5,900	UK207D1: HS2307.....	4,200		
ASS208-108N.....	3,700	JEL205-015.....	5,900	UK208D1: H2308X.....	3,700	UC2 SERIES	
ASS208-109N.....	3,700	JEL205-100.....	5,900	UK208D1: HE2308X.....	3,700	UC201D1.....	11,000
		JEL206.....	4,900	UK208D1: HS2308X.....	3,700	UC201-008D1.....	11,000
		JEL206-101.....	4,900	UK209D1: H2309X.....	3,500	UC202D1.....	10,000
AEL2 SERIES		JEL206-102.....	4,900	UK209D1: HA2309.....	3,500	UC202-009D1.....	10,000
AEL201.....	11,000	JEL206-103.....	4,900	UK209D1: HS2309X.....	3,500	UC202-010D1.....	10,000
AEL201-008.....	11,000	JEL206-104.....	4,900	UK209D1: HS2309X.....	3,500	UC203D1.....	8,000
AEL202.....	10,000	JEL207.....	4,200	UK210D1: H2310X.....	3,100	UC203-011D1.....	8,000
AEL202-009.....	10,000	JEL207-104.....	4,200	UK210D1: HS2310.....	3,100	UC204D1.....	6,700
AEL202-010.....	10,000	JEL207-105.....	4,200	UK210D1: HA2310.....	3,100	UC204-012D1.....	6,700
AEL203.....	8,000	JEL207-106.....	4,200	UK210D1: HE2310X.....	3,100	UC205D1.....	5,900
AEL203-011.....	8,000	JEL207-107.....	4,200	UK211D1: H2311X.....	2,900	UC205-013D1.....	5,900
AEL204.....	6,700	JEL208.....	3,700	UK211D1: HS2311.....	2,900	UC205-014D1.....	5,900
AEL204-012.....	6,700	JEL208-108.....	3,700	UK211D1: HA2311.....	2,900	UC205-015D1.....	5,900
AEL205.....	5,900	JEL208-109.....	3,700	UK211D1: HE2311XY.....	2,900	UC205-100D1.....	5,900
AEL205-013.....	5,900	JEL209.....	3,500	UK212D1: H2312X.....	2,500	UC206D1.....	4,900
AEL205-014.....	5,900	JEL209-110.....	3,500	UK212D1: HS2312.....	2,500	UC206-101D1.....	4,900
AEL205-015.....	5,900	JEL209-111.....	3,500	UK213D1: H2313X.....	2,400	UC206-102D1.....	4,900
AEL205-100.....	5,900	JEL209-112.....	3,500	UK213D1: HA2313X.....	2,400	UC206-103D1.....	4,900
AEL206.....	4,900						

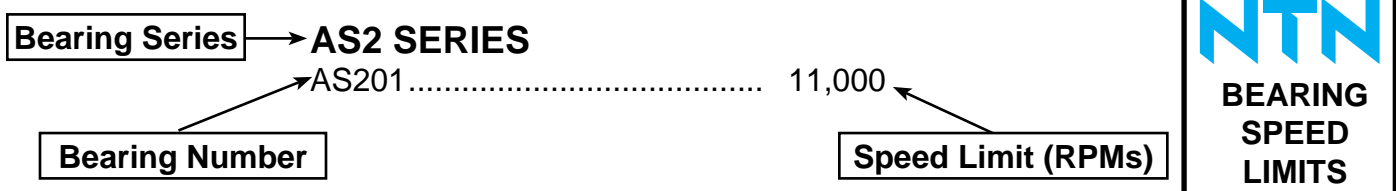

BALL BEARING INSERTS **RPMs**

UC206-104D1.....	4,900	UC314D1.....	2,100	UCS3 SERIES		UEL208-109D1.....	3,700
UC207D1.....	4,200	UC314-211D1.....	2,100	UCS305D1.....	5,400	UEL209D1.....	3,500
UC207-104D1.....	4,200	UC314-212D1.....	2,100	UCS305-014D1.....	5,400	UEL209-110D1.....	3,500
UC207-105D1.....	4,200	UC315D1.....	1,900	UCS305-015D1.....	5,400	UEL209-111D1.....	3,500
UC207-106D1.....	4,200	UC315-215D1.....	1,900	UCS305-100D1.....	5,400	UEL209-112D1.....	3,500
UC207-107D1.....	4,200	UC315-300D1.....	1,900	UCS306D1.....	4,400	UEL210D1.....	3,100
UC208D1.....	3,700	UC316D1.....	1,800	UCS306-102D1.....	4,400	UEL210-113D1.....	3,100
UC208-108D1.....	3,700	UC316-302D1.....	1,800	UCS306-103D1.....	4,400	UEL210-114D1.....	3,100
UC208-109D1.....	3,700	UC316-303D1.....	1,800	UCS307D1.....	4,000	UEL210-115D1.....	3,100
UC209D1.....	3,500	UC317D1.....	1,700	UCS307-104D1.....	4,000	UEL210-200D1.....	3,100
UC209-110D1.....	3,500	UC317-304D1.....	1,700	UCS307-105D1.....	4,000	UEL211D1.....	2,900
UC209-111D1.....	3,500	UC318D1.....	1,600	UCS307-106D1.....	4,000	UEL211-200D1.....	2,900
UC209-112D1.....	3,500	UC318-307D1.....	1,600	UCS307-107D1.....	4,000	UEL211-201D1.....	2,900
UC210D1.....	3,100	UC318-308D1.....	1,600	UCS308D1.....	3,500	UEL211-202D1.....	2,900
UC210-113D1.....	3,100	UC319D1.....	1,500	UCS308-108D1.....	3,500	UEL211-203D1.....	2,900
UC210-114D1.....	3,100	UC319-312D1.....	1,500	UCS309D1.....	3,100	UEL212D1.....	2,500
UC210-115D1.....	3,100	UC320D1.....	1,500	UCS309-110D1.....	3,100	UEL212-204D1.....	2,500
UC210-200D1.....	3,100	UC320-315D1.....	1,500	UCS309-111D1.....	3,100	UEL212-206D1.....	2,500
UC211D1.....	2,900	UC320-400D1.....	1,500	UCS309-112D1.....	3,100	UEL212-207D1.....	2,500
UC211-200D1.....	2,900	UC321D1.....	1,400	UCS310D1.....	2,800	UEL3 SERIES	
UC211-201D1.....	2,900	UC322D1.....	1,300	UCS310-114D1.....	2,800	UEL305D1.....	5,400
UC211-202D1.....	2,900	UCS2 SERIES		UCS310-115D1.....	2,800	UEL305-014D1.....	5,400
UC211-203D1.....	2,900	UCS201D1N.....	11,000	UCS311D1.....	2,600	UEL305-015D1.....	5,400
UC212D1.....	2,500	UCS201-008D1N.....	11,000	UCS311-200D1.....	2,600	UEL305-100D1.....	5,400
UC212-204D1.....	2,500	UCS202D1N.....	10,000	UCS311-202D1.....	2,600	UEL306D1.....	4,400
UC212-206D1.....	2,500	UCS202-009D1N.....	10,000	UCS311-203D1.....	2,600	UEL306-102D1.....	4,400
UC212-207D1.....	2,500	UCS202-010D1N.....	10,000	UCS312D1.....	2,400	UEL306-103D1.....	4,400
UC213D1.....	2,400	UCS203D1N.....	8,000	UCS312-204D1.....	2,400	UEL307D1.....	4,000
UC213-208D1.....	2,400	UCS203-011D1N.....	8,000	UCS312-207D1.....	2,400	UEL307-104D1.....	4,000
UC214D1.....	2,300	UCS204D1N.....	6,700	UCS313D1.....	2,200	UEL307-105D1.....	4,000
UC214-211D1.....	2,300	UCS204-012D1N.....	6,700	UCS313-208D1.....	2,200	UEL307-106D1.....	4,000
UC214-212D1.....	2,300	UCS205D1N.....	5,900	UCS314D1.....	2,100	UEL307-107D1.....	4,000
UC215D1.....	2,100	UCS205-013D1N.....	5,900	UCS314-211D1.....	2,100	UEL308D1.....	3,500
UC215-215D1.....	2,100	UCS205-014D1N.....	5,900	UCS314-212D1.....	2,100	UEL308-108D1.....	3,500
UC215-300D1.....	2,100	UCS205-015D1N.....	5,900	UCS315D1.....	1,900	UEL309D1.....	3,100
UC216D1.....	2,000	UCS205-100D1N.....	5,900	UCS315-215D1.....	1,900	UEL309-110D1.....	3,100
UC216-302D1.....	2,000	UCS206D1N.....	4,900	UCS315-300D1.....	1,900	UEL309-111D1.....	3,100
UC217D1.....	1,900	UCS206-101D1N.....	4,900	UCS316D1.....	1,800	UEL309-112D1.....	3,100
UC217-304D1.....	1,900	UCS206-102D1N.....	4,900	UCS316-302D1.....	1,800	UEL310D1.....	2,800
UC218D1.....	1,700	UCS206-103D1N.....	4,900	UCS316-303D1.....	1,800	UEL310-114D1.....	2,800
UC218-308D1.....	1,700	UCS207D1N.....	4,200	UCS317D1.....	1,700	UEL310-115D1.....	2,800
UC3 SERIES		UCS207-104D1N.....	4,200	UCS317-304D1.....	1,700	UEL311D1.....	2,600
UC305D1.....	5,400	UCS207-105D1N.....	4,200	UCS318D1.....	1,600	UEL311-200D1.....	2,600
UC305-014D1.....	5,400	UCS207-106D1N.....	4,200	UCS318-307D1.....	1,600	UEL311-202D1.....	2,600
UC305-015D1.....	5,400	UCS207-107D1N.....	4,200	UCS318-308D1.....	1,600	UEL311-203D1.....	2,600
UC305-100D1.....	5,400	UCS208D1N.....	3,700	UCS319D1.....	1,500	UEL312D1.....	2,400
UC306D1.....	4,400	UCS208-108D1N.....	3,700	UCS319-312D1.....	1,500	UEL312-204D1.....	2,400
UC306-102D1.....	4,400	UCS208-109D1N.....	3,700	UCS320D1.....	1,500	UEL312-206D1.....	2,400
UC306-103D1.....	4,400	UCS209D1N.....	3,500	UCS320-315D1.....	1,500	UEL312-207D1.....	2,400
UC307D1.....	4,000	UCS209-110D1N.....	3,500	UCS320-400D1.....	1,500	UEL313D1.....	2,200
UC307-104D1.....	4,000	UCS209-111D1N.....	3,500	UCS321D1.....	1,400	UEL313-208D1.....	2,200
UC307-105D1.....	4,000	UCS209-112D1N.....	3,500	UCS322D1.....	1,300	UEL314D1.....	2,100
UC307-106D1.....	4,000	UCS210D1N.....	3,100	UEL2 SERIES		UEL314-211D1.....	2,100
UC307-107D1.....	4,000	UCS210-113D1N.....	3,100	UEL204D1.....	6,700	UEL314-212D1.....	2,100
UC308D1.....	3,500	UCS210-114D1N.....	3,100	UEL204-012D1.....	6,700	UEL315D1.....	1,900
UC308-108D1.....	3,500	UCS210-115D1N.....	3,100	UEL205D1.....	5,900	UEL315-215D1.....	1,900
UC309D1.....	3,100	UCS211D1N.....	2,900	UEL205-013D1.....	5,900	UEL315-300D1.....	1,900
UC309-110D1.....	3,100	UCS211-200D1N.....	2,900	UEL205-014D1.....	5,900	UEL316D1.....	1,800
UC309-111D1.....	3,100	UCS211-201D1N.....	2,900	UEL205-015D1.....	5,900	UEL316-302D1.....	1,800
UC309-112D1.....	3,100	UCS211-202D1N.....	2,900	UEL205-100D1.....	5,900	UEL316-303D1.....	1,800
UC310D1.....	2,800	UCS211-203D1N.....	2,900	UEL206D1.....	4,900	UEL317D1.....	1,700
UC310-114D1.....	2,800	UCS212D1.....	2,500	UEL206-101D1.....	4,900	UEL317-304D1.....	1,700
UC310-115D1.....	2,800	UCS212-204D1.....	2,500	UEL206-102D1.....	4,900	UEL318D1.....	1,600
UC311D1.....	2,600	UCS212-206D1.....	2,500	UEL206-103D1.....	4,900	UEL318-307D1.....	1,600
UC311-200D1.....	2,600	UCS212-207D1.....	2,500	UEL206-104D1.....	4,900	UEL318-308D1.....	1,600
UC311-202D1.....	2,600	UCS213D1.....	2,400	UEL207D1.....	4,200	UEL319D1.....	1,500
UC311-203D1.....	2,600	UCS213-208D1.....	2,400	UEL207-104D1.....	4,200	UEL319-312D1.....	1,500
UC312D1.....	2,400	UCS214D1.....	2,300	UEL207-105D1.....	4,200	UEL320D1.....	1,500
UC312-204D1.....	2,400	UCS215D1.....	2,100	UEL207-106D1.....	4,200	UEL320-315D1.....	1,500
UC312-206D1.....	2,400	UCS216D1.....	2,000	UEL207-107D1.....	4,200	UEL320-400D1.....	1,500
UC312-207D1.....	2,400	UCS217D1.....	1,900	UEL208D1.....	3,700	UEL321D1.....	1,400
UC313D1.....	2,200	UCS218D1.....	1,700	UEL208-108D1.....	3,700	UEL322D1.....	1,300
UC313-208D1.....	2,200						



Units: INCHES

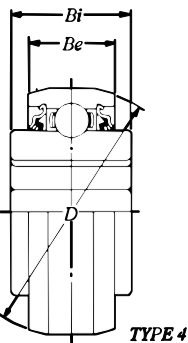
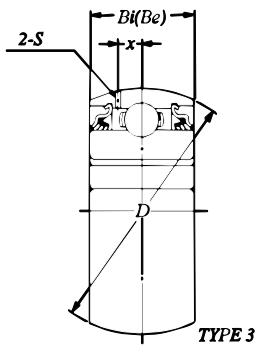
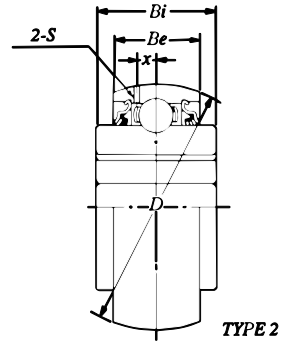
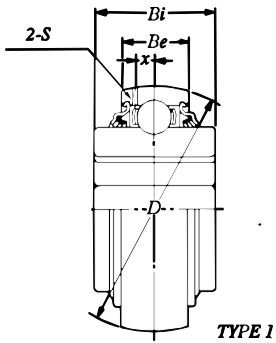
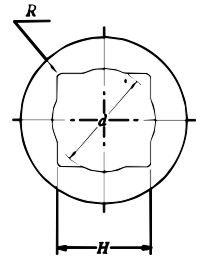
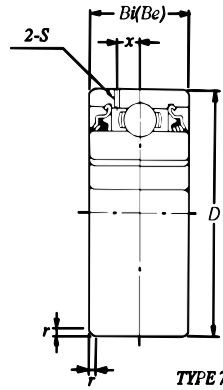
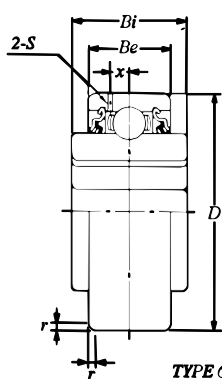
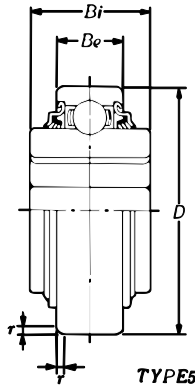
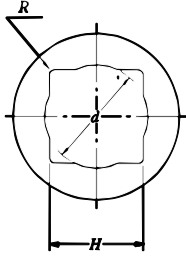

DISC HARROW BEARINGS

Bearing No.	Type	Shaft Size	Sq. Bore Dim. ±.005	Max. d	Max. R	Outside Diameter D	Ring Widths		r	s	x	Basic Load Ratings (lbs)		Weight (lbs)
							Be	Bi				C _D	C _S	
4AS08-7/8	4	7/8	.9050	.961	.089	3.4385/3.4375	1.189	1.437	—	—	—	6,500	4,000	2.02
1AS08-1	1	1	1.0300	1.094	.089	3.1496/3.1491	.709	1.437	—	—	—	6,500	4,000	1.38
2AS08-1	2	1	1.0300	1.094	.089	3.1496/3.1491	1.189	1.437	—	—	—	6,500	4,000	1.68
4AS08-1	4	1	1.0300	1.094	.089	3.4385/3.4375	1.189	1.437	—	—	—	6,500	4,000	1.94
1AS08-1 1/8	1	1 1/8	1.1800	1.236	.089	3.1496/3.1491	.709	1.437	—	—	—	6,500	4,000	1.27
2AS08-1 1/8	2	1 1/8	1.1800	1.236	.089	3.1496/3.1491	1.189	1.437	—	—	—	6,500	4,000	1.57
2AS08-1 1/8 D1	2	1 1/8	1.1800	1.236	.089	3.1496/3.1491	1.189	1.437	—	.087	.260	6,500	4,000	1.57
4AS08-1 1/8	4	1 1/8	1.1800	1.236	.089	3.4385/3.4375	1.189	1.437	—	—	—	6,500	4,000	1.83
1AS08-1 1/2 D1	1	1 1/2	1.1811	1.252	.089	3.1496/3.1491	.827	1.437	—	.087	.260	6,500	4,000	1.27
2AS09-1 1/4 D1	2	1 1/4	1.2900	1.370	.089	3.3465/3.3459	1.189	1.437	—	.087	.264	7,350	4,600	1.75
4AS09-1 1/4	4	1 1/4	1.2900	1.370	.089	3.4424/3.4346	1.189	1.437	—	—	—	7,350	4,600	1.81
2AS10-1 1/8	2	1 1/8	1.1800	1.236	.089	3.5433/3.5427	1.189	1.437	—	—	—	7,900	5,200	2.13
3AS10-1 1/8	3	1 1/8	1.1800	1.236	.089	3.5433/3.5427	1.189	1.189	—	—	—	7,900	5,200	1.90
1AS11-1 1/2 D1	1	1 1/2	1.5311	1.622	.089	3.9370-3.9364	.984	1.750	—	.098	.299	9,750	6,550	2.56
3AS11-1 1/2	3	1 1/2	1.5311	1.622	.089	3.9370-3.9364	1.311	1.311	—	—	—	9,750	6,550	2.40
3AS11-1 1/2 D1	3	1 1/2	1.5311	1.622	.089	3.9370-3.9364	1.311	1.311	—	.098	.299	9,750	6,550	2.40
4AS11-1 1/2	4	1 1/2	1.5311	1.622	.089	4.1250/4.1200	1.437	1.750	—	—	—	9,750	6,550	3.20
3AS14-2D1	3	2	2.0551	2.161	.157	4.9213/4.9205	1.563	1.563	—	.118	.370	14,000	9,900	4.30
5AS08-1 1/8	5	1 1/8	1.1800	1.236	.089	3.1496/3.1491	.709	1.437	.079	—	—	6,550	4,000	1.27
6AS08-1 1/8 D1	6	1 1/8	1.1800	1.236	.089	3.1496/3.1491	1.189	1.437	.079	.087	.264	6,550	4,000	1.57
6AS09-1 1/4	6	1 1/4	1.2900	1.370	.089	3.3460/3.3450	1.189	1.437	.079	—	—	7,350	4,600	1.75
6AS09-1 1/4 D1	6	1 1/4	1.2900	1.370	.089	3.3460/3.3450	1.189	1.437	.079	.087	.260	7,350	4,600	1.75
7AS10-1 1/8 D1	7	1 1/8	1.1800	1.236	.089	3.5433/3.5427	1.189	1.189	.079	0.87	.264	7,900	5,200	1.90
6AS11-1 1/2 V1	6	1 1/2	1.5311	1.622	.089	4.0000/3.9990	1.437	1.750	.098	—	—	9,750	6,550	3.06
7AS11-1 1/2	7	1 1/2	1.5311	1.622	.089	3.9370/3.9364	1.311	1.311	.098	—	—	9,750	6,550	2.40
7AS11-1 1/2 D1	7	1 1/2	1.5311	1.622	.089	3.9370/3.9364	1.311	1.311	.098	.098	.299	9,750	6,550	2.40

Ring width tolerances are:
 Sizes up to and including AS110 +.000 to -.005
 AS11 through A14, +.000 to -.006

Units: INCHES

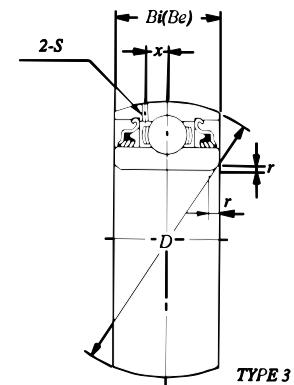
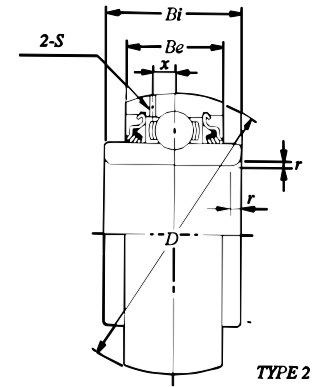
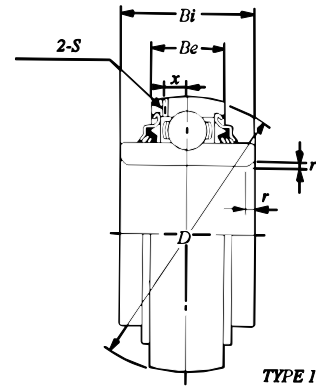
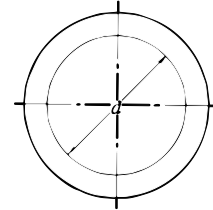
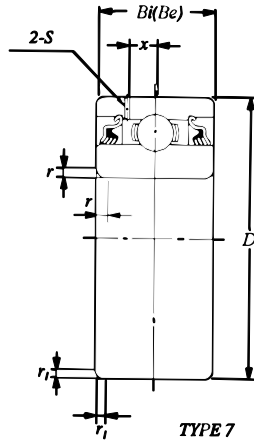
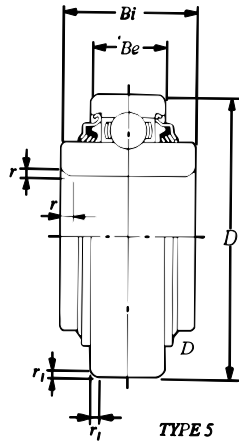
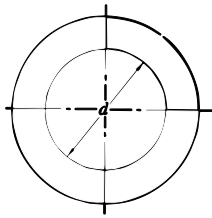

DISC HARROW BEARINGS

Bearing No.	Type	Bore <i>d</i>	Outside Diameter <i>D</i>	Ring Widths		<i>r</i>	<i>r_i</i>	<i>s</i>	<i>x</i>	Basic Load Ratings (lbs)		Weight (lbs)
				<i>Be</i>	<i>Bi</i>					Dynamic <i>C</i>	Static <i>C_o</i>	
1AC08-1 3/16	1	1.1880/1.1875	3.1496/3.1491	.709	1.189	.079	—	—	—	6,550	4,000	1.22
2AC08-1 1/2D1	2	1.5005/1.5000	3.1496/3.1491	1.189	1.689	.079	—	.087	.260	6,550	4,000	1.60
1AC09D1V1	1	1.7776/1.7717	3.3465/3.3459	.866	1.437	.079	—	.087	.264	7,350	4,600	1.30
3AC09	3	1.7717/1.7712	3.3465/3.3459	1.189	1.189	.079	—	—	—	7,350	4,600	1.44
3AC09D1	3	1.7717/1.7712	3.3465/3.3459	1.189	1.189	.079	—	.087	.284	7,350	4,600	1.44
3AC09-1 1/2	3	1.5350/1.5250	3.3465/3.3459	1.189	1.189	.079	—	—	—	7,350	4,600	1.58
3AC09-1 1/2D1	3	1.5350/1.5250	3.3465/3.3459	1.189	1.189	.079	—	.087	.264	7,350	4,600	1.58
3AC10-1 3/4	3	1.7850/1.7750	3.5433/3.5427	1.189	1.189	.079	—	—	—	7,900	5,200	1.68
3AC10-1 3/4D1	3	1.7850/1.7750	3.5433/3.5427	1.189	1.189	.079	—	.087	.264	7,900	5,200	1.68
3AC10-1 15/16	3	1.9380/1.9375	3.5433/3.5427	1.189	1.189	.079	—	—	—	7,900	5,200	1.57
3AC10-1 15/16D1	3	1.9380/1.9375	3.5433/3.5427	1.189	1.189	.079	—	.087	.264	7,900	5,200	1.57
1AC11-2 3/16D1V1	1	2.1939/2.1880	3.9370/3.9364	.984	1.563	.098	—	.098	.299	9,750	6,550	1.92
3AC11-2 3/16	3	2.1880/2.1874	3.9370/3.9364	1.311	1.311	.098	—	—	—	9,750	6,550	2.11
3AC11-2 3/16D1	3	2.1880/2.1874	3.9370/3.9364	1.311	1.311	.098	—	.098	.299	9,750	6,550	2.11
3AC14D1	3	2.7559/2.7553	4.9213/4.9205	1.563	1.563	.098	—	.118	.370	14,000	9,900	3.44
5AC10-1 15/16	5	1.9380/1.9375	3.5433/3.5427	.787	1.937	.079	.079	—	—	7,900	5,200	1.62
7AC10-1 15/16	7	1.9380/1.9375	3.5433/3.5427	1.189	1.189	.079	.079	—	—	7,900	5,200	1.57
7AC11-2 3/16D1	7	2.1880/2.1874	3.9370/3.9364	1.311	1.311	.098	.098	.098	.299	9,750	6,550	2.11



Units: INCHES

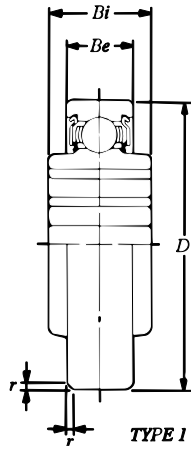

TYPE 1

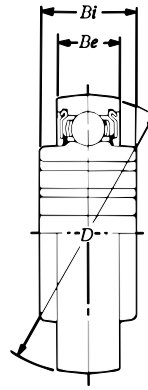

TYPE 2

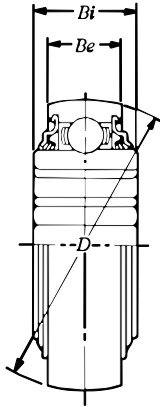
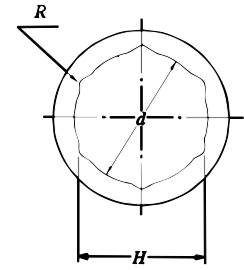

TYPE 2...V2

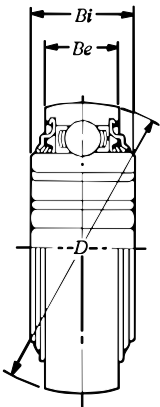

TYPE 2...V2

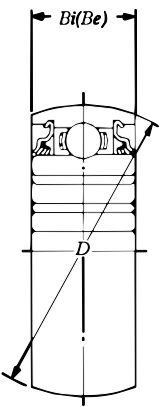

TYPE 3...V2

HEX BORE BEARINGS

Bearing No.	Type	Shaft Size	Hex Bore +0.005 -0.000 H	Max.		Outside Diameter D	Ring Widths ±.005		r	Basic Load Ratings (lbs)		Weight (lbs)
				d	R		Be	Bi		Dynamic C	Static Co	
1AH04-1 1/16	1	1 1/16	.695	.713	.010	1.8504/1.8499	.551	.827	.059	2,890	1,500	.289
1AH05-7/8	1	7/8	.876	.898	.010	2.0472/2.0467	.591	1.000	.059	3,150	1,770	.379
2AH05-7/8	2	7/8	.876	.898	.010	2.0472/2.0467	.591	1.000	—	3,150	1,770	.379
1AH06-1	1	1	1.001	1.028	.010	2.4409/2.4404	.630	.945	.059	4,400	2,540	.558
2AH06-1	2	1	1.001	1.028	.010	2.4409/2.4404	.630	.945	—	4,400	2,540	.558
2AH07-1 1/8	2	1 1/8	1.126	1.154	.010	2.8346/2.8341	.669	1.484	—	5,750	3,450	1.02
2AH08-1 1/4V2	2	1 1/4	1.260	1.287	.010	3.1496/3.1491	.709	1.437	—	6,550	4,000	1.28
2AH09-1 1/2	2	1 1/2	1.501	1.535	.010	3.3465/3.3459	.748	1.181	—	7,350	4,600	1.22
3AH10-1 5/8V2	3	1 5/8	1.626	1.665	.010	3.5433/3.5427	1.189	1.189	—	7,900	5,200	1.63

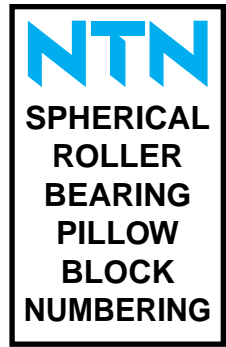

Metric Series

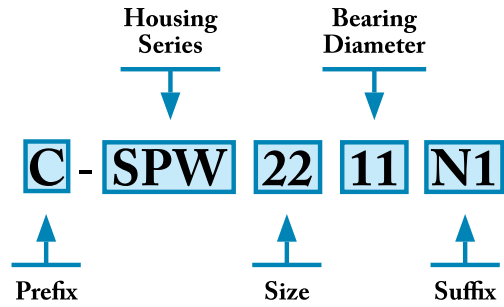

Inch Series

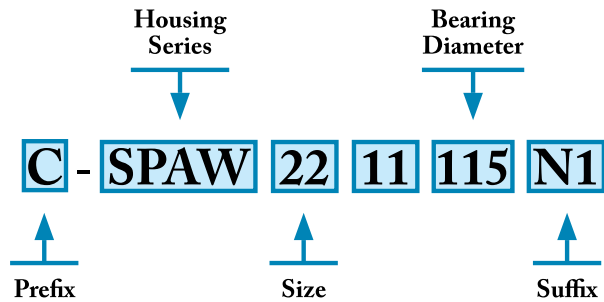

1. PREFIX

C: Taconite service seals
 CM: Taconite service seal + end cover

2. HOUSING SERIES

SPW: Sealed spherical pillow block, metric with inch shaft dimension
 SPAW: Sealed spherical pillow block, inch*
 SFCW: Sealed spherical flanged block, metric
 SAF: Split pillow block, cast iron housing
 SAFS: Split pillow block, cast steel housing
 PSAF: Split pillow block, cast iron, 4 bolt option
 FSPAW: Sealed pillow block, inch, 4 bolt option

3. BEARING

W22xx: MX-W222xx Series sealed spherical roller bearing

4. Bore Diameter (-Xnn)

X: Number of inches
 nn: Number of 1/16 inches
 e.g.: -115 indicates a 1-15/16" bore

5. SUFFIX

N1: Ductile cast iron housing
 F: Solid base
 G: One stabilizing ring included

* SPAW dimensionally the same as SAF housing

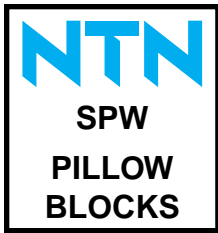

Units: Millimeters
INCHES

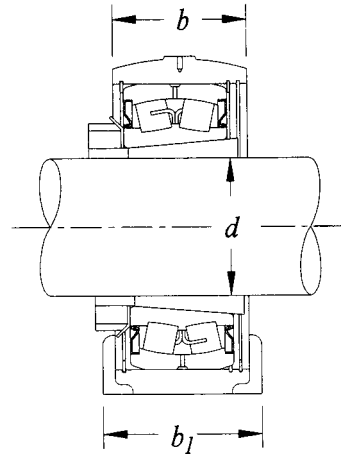
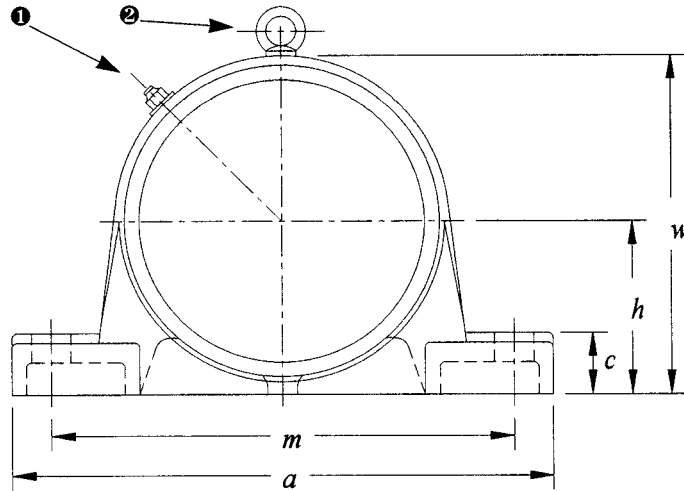

SPW22...

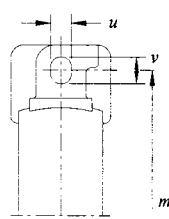

2 Bolt Base

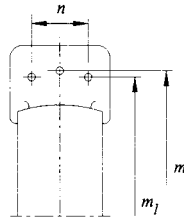

Solid Base

SPW PILLOW BLOCKS

Shaft Diameter <i>d</i> Inches	Complete Pillow Block Number	Pillow Block Housing	Bearing Number	Basic Load Ratings (lbs)		Adaptaer Locknut and Lockwasher	Weight (lbs)
				<i>Dynamic</i> <i>C</i>	<i>Static</i> <i>C₀</i>		
1 15/16 50 2	SPW2211-115N1 SPW2211N1 SPW2211-200N1	SP211N1 SP211N1 SP211N1	MX-W22211BLLKC3 MX-W22211BLLKC3 MX-W22211BLLKC3	21,000 21,000 21,000	24,700 24,700 24,700	HA2311M1 H2311XM1 HE2311XYM1	13 13 13
2 3/16 2 1/4 60 2 3/8	SPW2213-203N1 SPW2213-204N1 SPW2213N1 SPW2213-206N1	SP213N1 SP213N1 SP213N1 SP213N1	MX-W22213BLLKC3 MX-W22213BLLKC3 MX-W22213BLLKC3 MX-W22213BLLKC3	32,000 32,000 32,000 32,000	40,000 40,000 40,000 40,000	HA2313M1 HE2313XM1 H2313XM1 HS2313XM1	18 18 18 18
2 7/16 2 1/2 65	SPW2215-207N1 SPW2215-208N1 SPW2215N1	SP215N1 SP215N1 SP215N1	MX-W22215BLLKC3 MX-W22215BLLKC3 MX-W22215BLLKC3	37,500 37,500 37,500	50,000 50,000 50,000	HA2315M1 HE2315XM1 H2315XM1	20 20 20
2 15/16 75 3	SPW2217-215N1 SPW2217N1 SPW2217-300N1	SP217N1 SP217N1 SP217N1	MX-W22217BLLKC3 MX-W22217BLLKC3 MX-W22217BLLKC3	46,500 46,500 46,500	61,000 61,000 61,000	HA2317XM1 H2317XM1 HE2317XM1	31 31 31
3 7/16 3 1/2 90	SPW2220-307N1 SPW2220-308N1 SPW2220N1	SP220N1 SP220N1 SP220N1	MX-W22220BLLKC3 MX-W22220BLLKC3 MX-W22220BLLKC3	69,500 69,500 69,500	92,000 92,000 92,000	HA2320M1 HE2320XM1 H2320XM1	54 54 54
100 3 15/16 4	SPW2222N1 SPW2222-315N1 SPW2222-400N1	SP222N1 SP222N1 SP222N1	MX-W22222BLLKC3 MX-W22222BLLKC3 MX-W22222BLLKC3	92,000 92,000 92,000	128,000 128,000 128,000	HA2322XM1 H2322M1 HE2322XM1	71 71 71
4 3/16 4 1/4 110	SPW2224-403N1 SPW2224-404N1 SPW2224N1	SP224N1 SP224N1 SP224N1	MX-W22224BLLKC3 MX-W22224BLLKC3 MX-W22224BLLKC3	109,000 109,000 109,000	157,000 157,000 157,000	HA2324M1 HE2324M1 H2324XM1	84 84 84
4 7/16 4 1/2 115	SPW2226-407N1 SPW2226-408N1 SPW2226N1	SP226N1 SP226N1 SP226N1	MX-W22226BLLKC3 MX-W22226BLLKC3 MX-W22226BLLKC3	127,000 127,000 127,000	176,000 176,000 176,000	HA2326M1 HE2326M1 H2326M1	101 101 101
125 4 15/16 5	SPW2228N1 SPW2228-415N1 SPW2228-500N1	SP228N1 SP228N1 SP228N1	MX-W22228BLLKC3 MX-W22228BLLKC3 MX-W22228BLLKC3	153,000 153,000 153,000	218,000 218,000 218,000	H2328M1 HA2328M1 HE2328M1	118 118 118
5 7/16 5 1/2 140	SPW2232-507N1 SPW2232-508N1 SPW2232N1	SP232N1 SP232N1 SP232N1	MX-W22232BLLKC3 MX-W22232BLLKC3 MX-W22232BLLKC3	196,000 196,000 196,000	290,000 290,000 290,000	HA2332M1 HE2332M1 H2332M1	171 171 171

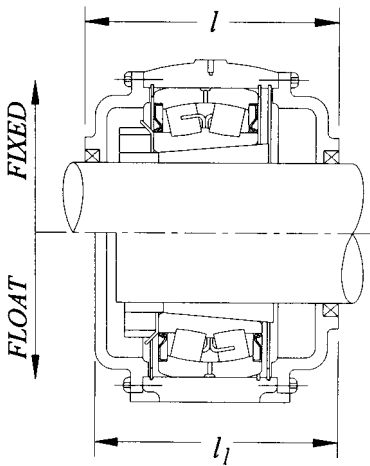

C(M)-SPW22...

How to Order

Example: When you order one SPW2220N1, you will receive an assembly consisting of one SP220N1 Pillow Block Housing, one MX-W22220BLLKC3 Bearing, and one H2320XM1 Adapter.

To order a solid base housing, add suffix F to the part number (example: SPW2220FN1).

When C-SPW2220N1 or CM-SPW2220N1 are specified, external covers will be supplied with the unit.

Example: "C" prefix - 2 taconite service seals

"CM" prefix - 1 taconite service seal, 1 end cover

Notes: Taconite service seals for which dimensions are shown are standard. For dimensions and availability of non-standard taconite service seals, consult NTN Engineering.

All units are supplied in float arrangement and may be converted to fixed by relocation of a snap ring.

All bearing inserts are supplied prelubricated with Shell Alvania™ 3 grease.

Solid base housings may be drilled for 2 or 4 bolt arrangement.

Grease fittings are provided with all units.

An eye bolt is provided on housings SP228N1 and SP23N1.

SPW PILLOW BLOCKS

Complete Pillow Block Number	Dimensions (Millimeters)													Set Bolts	
	h	a	b	b1	c	m	m1	n	w	l	l1	u	v	(2 req'd)	(4 req'd)
SPW2211-115N1	70	255	62	70	28	210	200	40	136	120	114	18	23	M16	M12
SPW2211N1	70	255	62	70	28	210	200	40	136	120	114	18	23	M16	M12
SPW2211-200N1	70	255	62	70	28	210	200	40	136	120	114	18	23	M16	M12
SPW2213-203N1	80	275	70	80	30	230	220	48	157	138	126	18	23	M16	M12
SPW2213-204N1	80	275	70	80	30	230	220	48	157	—	—	18	23	M16	M12
SPW2213N1	80	275	70	80	30	230	220	48	157	—	—	18	23	M16	M12
SPW2213-206N1	80	275	70	80	30	230	220	48	157	—	—	18	23	M16	M12
SPW2215-207N1	80	280	72	80	30	230	220	48	163	132	123	18	23	M16	M12
SPW2215-208N1	80	280	72	80	30	230	220	48	163	—	—	18	23	M16	M12
SPW2215N1	80	280	72	80	30	230	220	48	163	—	—	18	23	M16	M12
SPW2217-216N1	95	320	80	90	32	260	252	52	192	156	146	22	27	M20	M16
SPW2217N1	95	320	80	90	32	260	252	52	192	—	—	22	27	M20	M16
SPW2217-300N1	95	320	80	90	32	260	252	52	192	—	—	22	27	M20	M16
SPW2220-307N1	112	380	95	110	40	320	300	66	226	185	175	26	32	M24	M16
SPW2220-308N1	112	380	95	110	40	320	300	66	226	—	—	26	32	M24	M16
SPW2220N1	112	380	95	110	40	320	300	66	226	—	—	26	32	M24	M16
SPW2222N1	125	410	100	120	45	350	320	74	252	—	—	26	32	M24	M16
SPW2222-315N1	125	410	100	120	45	350	320	74	252	198	185	26	32	M24	M16
SPW2222-400N1	125	410	100	120	45	350	320	74	252	—	—	26	32	M24	M16
SPW2224-403N1	140	410	105	120	45	350	330	74	274	203	190	26	32	M24	M16
SPW2224-404N1	140	410	105	120	45	350	330	74	274	—	—	26	32	M24	M16
SPW2224N1	140	410	105	120	45	350	330	74	274	—	—	26	32	M24	M16
SPW2226-407N1	150	445	115	130	50	380	370	80	293	219	206	28	36	M24	M20
SPW2226-408N1	150	445	115	130	50	380	370	80	293	—	—	28	36	M24	M20
SPW2226N1	150	445	115	130	50	380	370	80	293	—	—	28	36	M24	M20
SPW2228N1	150	500	120	150	50	420	400	80	305	—	—	33	42	M30	M24
SPW2228-415N1	150	500	120	150	50	420	400	80	305	232	219	33	42	M30	M24
SPW2228-500N1	150	500	120	150	50	420	400	80	305	—	—	33	42	M30	M24
SPW2232-507N1	170	550	135	160	60	470	450	90	340	260	247	33	42	M30	M24
SPW2232-508N1	170	550	135	160	60	470	450	90	340	—	—	33	42	M30	M24
SPW2232N1	170	550	135	160	60	470	450	90	340	—	—	33	42	M30	M24

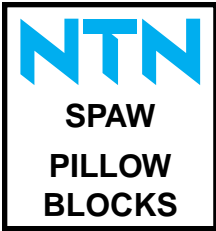

Units: Millimeters
INCHES

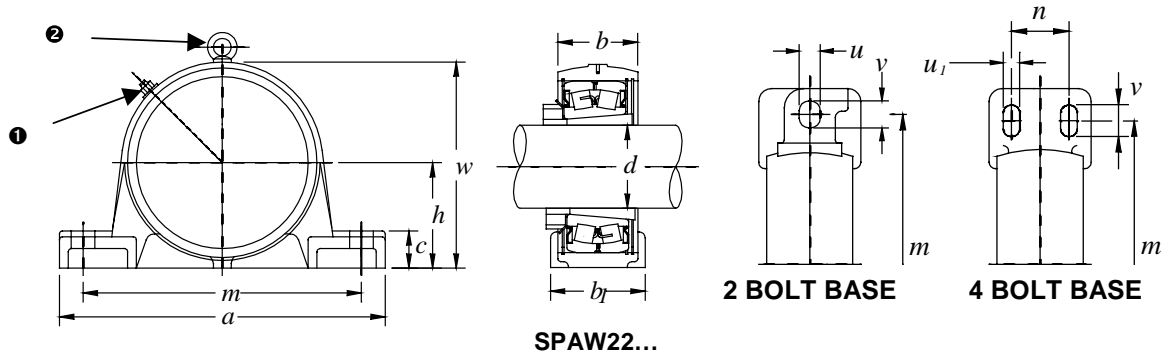

SPAW PILLOW BLOCKS

Shaft Diameter <i>d</i> Inches	Complete Pillow Block Number	Flange Block Housing	Bearing Number	Basic Load Ratings (lbs)		Adaptaer Locknut and Lockwasher	Weight (lbs)
				<i>Dynamic C</i>	<i>Static Co</i>		
1 ¹⁵ / ₁₆ 50 2	SPAW2211-115N1	SPA211N1	MX-W22211BLLKC3	21,000	24,700	HA2311M1	13
	SPAW2211N1	SPA211N1	MX-W22211BLLKC3	21,000	24,700	H2311XM1	13
	SPAW2211-200N1	SPA211N1	MX-W22211BLLKC3	21,000	24,700	HE2311XYM1	13
2 ³ / ₁₆	SPAW2213-203N1	SPA213N1	MX-W22213BLLKC3	32,000	40,000	HA2313M1	18
	FSPA2213-203N1	FSPA213N1	MX-W22213BLLKC3	32,000	40,000	HA2313M1	18
2 ¹ / ₄	SPAW2213-204N1	SPA213N1	MX-W22213BLLKC3	32,000	40,000	HE2313XM1	18
	FSPA2213-204N1	FSPA213N1	MX-W22213BLLKC3	32,000	40,000	HE2313XM1	18
60	SPAW2213N1	SPA213N1	MX-W22213BLLKC3	32,000	40,000	H2313XM1	18
	FSPA2213N1	FSPA213N1	MX-W22213BLLKC3	32,000	40,000	H2313XM1	18
2 ³ / ₈	SPAW2213-206N1	SPA213N1	MX-W22213BLLKC3	32,000	40,000	HS2313XM1	18
	FSPA2213-206N1	FSPA213N1	MX-W22213BLLKC3	32,000	40,000	HS2313XM1	18
2 ⁷ / ₁₆	SPAW2215-207N1	SPA215N1	MX-W22215BLLKC3	37,500	50,000	HA2315M1	20
	FSPA2215-207N1	FSPA215N1	MX-W22215BLLKC3	37,500	50,000	HA2315M1	20
2 ¹ / ₂	SPAW2215-208N1	SPA215N1	MX-W22215BLLKC3	37,500	50,000	HE2315XM1	20
	FSPA2215-208N1	FSPA215N1	MX-W22215BLLKC3	37,500	50,000	HE2315XM1	20
65	SPAW2215N1	SPA215N1	MX-W22215BLLKC3	37,500	50,000	H2315XM1	20
	FSPA2215N1	FSPA215N1	MX-W22215BLLKC3	37,500	50,000	H2315XM1	20
2 ¹⁵ / ₁₆	SPAW2217-215N1	SPA217N1	MX-W22217BLLKC3	46,500	61,000	HA2317XM1	31
	FSPA2217-215N1	FSPA217N1	MX-W22217BLLKC3	46,500	61,000	HA2317XM1	31
75	SPAW2217N1	SPA217N1	MX-W22217BLLKC3	46,500	61,000	H2317XM1	31
	FSPA2217N1	FSPA217N1	MX-W22217BLLKC3	46,500	61,000	H2317XM1	31
3	SPAW2217-300N1	SPA217N1	MX-W22217BLLKC3	46,500	61,000	HE2317XM1	31
	FSPA2217-300N1	FSPA217N1	MX-W22217BLLKC3	46,500	61,000	HE2317XM1	31
3 ⁷ / ₁₆	SPAW2220-307N1	SPA220N1	MX-W22220BLLKC3	69,500	92,000	HA2320M1	54
	FSPA2220-307N1	FSPA220N1	MX-W22220BLLKC3	69,500	92,000	HA2320M1	54
3 ¹ / ₂	SPAW2220-308N1	SPA220N1	MX-W22220BLLKC3	69,500	92,000	HE2320XM1	54
	FSPA2220-308N1	FSPA220N1	MX-W22220BLLKC3	69,500	92,000	HE2320XM1	54
90	SPAW2220N1	SPA220N1	MX-W22220BLLKC3	69,500	92,000	H2320XM1	54
	FSPA2220N1	FSPA220N1	MX-W22220BLLKC3	69,500	92,000	H2320XM1	54
100	SPAW2222N1	SPA222N1	MX-W22222BLLKC3	92,000	128,000	H2322XM1	71
3 ¹⁵ / ₁₆	SPAW2222-315N1	SPA222N1	MX-W22222BLLKC3	92,000	128,000	HA2322XM1	71
	FSPA2222-400N1	SPA222N1	MX-W22222BLLKC3	92,000	128,000	HE2322XM1	71
4 ³ / ₁₆	SPAW2224-403N1	SPA224N1	MX-W22224BLLKC3	109,000	157,000	HA2324M1	84
	SPAW2224-404N1	SPA224N1	MX-W22224BLLKC3	109,000	157,000	HE2324M1	84
110	SPAW2224N1	SPA224N1	MX-W22224BLLKC3	109,000	157,000	H2324XM1	84
4 ⁷ / ₁₆	SPAW2226-407N1	SPA226N1	MX-W22226BLLKC3	127,000	176,000	HA2326M1	101
	SPAW2226-408N1	SPA226N1	MX-W22226BLLKC3	127,000	176,000	HE2326M1	101
115	SPAW2226N1	SPA226N1	MX-W22226BLLKC3	127,000	176,000	H2326M1	101
125	SPAW2228N1	SPA228N1	MX-W22228BLLKC3	153,000	218,000	H2328M1	118
	SPAW2228-415N1	SPA228N1	MX-W22228BLLKC3	153,000	218,000	HA2328M1	118
4 ¹⁵ / ₁₆	SPAW2228-500N1	SPA228N1	MX-W22228BLLKC3	153,000	218,000	HE2328M1	118
	SPAW2232-507N1	SPA232N1	MX-W22232BLLKC3	196,000	290,000	HA2332M1	171
5 ⁷ / ₁₆	SPAW2232-508N1	SPA232N1	MX-W22232BLLKC3	196,000	290,000	HE2332M1	171
	FSPA2232N1	SPA232N1	MX-W22232BLLKC3	196,000	290,000	H2332M1	171
140	SPAW2232N1	SPA232N1	MX-W22232BLLKC3	196,000	290,000	H2332M1	171

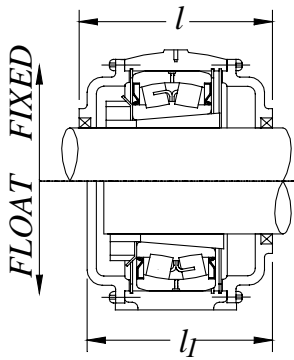

C(M)-SPA22...

How to Order

Example: When you order one SPAW2220-307N1, you will receive an assembly consisting of one SPA220N1 Pillow Block Housing, one MX-W22220BLLKC3 Bearing, and one HA2320M1 Adapter.

When C-SPA2220N1 or CM-SPA2220N1 are specified, external covers will be supplied with the unit.

Example: "C" prefix - 2 taconite service seals
"CM" prefix - 1 taconite service seal, 1 end cover

Notes: Taconite service seals for which dimensions are shown are standard. For dimensions and availability of non-standard taconite service seals, consult NTN Engineering.

All units are supplied in float arrangement and may be converted to fixed by relocation of a snap ring.

All bearing inserts are supplied prelubricated with Shell Alvania™ 3 grease.

Grease fittings are provided with all units.
An eye bolt is provided on housings SPA28N1 and SPA32N1.

SPA22 PILLOW BLOCKS

Complete Pillow Block Number	Dimensions (Inches)													Set Bolts	
	h	a	b	b1	c	m	n	w	l	l1	u	v	Size	No.	
SPA2211-115N1	2 3/4	9.606	2.441	2.756	1.102	7 5/8	-	5.354	4.724	4.488	0.709	-	7/8	5/8	2
SPA2211N1	2 3/4	9.606	2.441	2.756	1.102	7 5/8	-	5.354	4.724	4.488	0.709	-	7/8	5/8	2
SPA2211-200N1	2 3/4	9.606	2.441	2.756	1.102	7 5/8	-	5.354	4.724	4.488	0.709	-	7/8	5/8	2
SPA2213-203N1	3	10.827	2.756	3.110	1.024	8 13/16	2	6.024	5.433	4.961	0.709	-	1 5/16	5/8	2
FSPA2213-203N1	3	10.827	2.756	3.110	1.024	8 13/16	2	6.024	5.433	4.961	-	0.591	1 5/16	1/2	4
SPA2213-204N1	3	10.827	2.756	3.110	1.024	8 13/16	2	6.024	5.433	4.961	0.709	-	1 5/16	5/8	2
FSPA2213-204N1	3	10.827	2.756	3.110	1.024	8 13/16	2	6.024	5.433	4.961	-	0.591	1 5/16	1/2	4
SPA2213N1	3	10.827	2.756	3.110	1.024	8 13/16	2	6.024	5.433	4.961	0.709	-	1 5/16	5/8	2
FSPA2213N1	3	10.827	2.756	3.110	1.024	8 13/16	2	6.024	5.433	4.961	-	0.591	1 5/16	1/2	4
SPA2213-206N1	3	10.827	2.756	3.110	1.024	8 13/16	2	6.024	5.433	4.961	0.709	-	1 5/16	5/8	2
FSPA2213-206N1	3	10.827	2.756	3.110	1.024	8 13/16	2	6.024	5.433	4.961	-	0.591	1 5/16	1/2	4
SPA2215-207N1	3 1/4	11.024	2.835	3.110	1.299	9 1/8	1 7/8	6.535	5.197	4.843	0.709	-	1 1/8	5/8	2
FSPA2215-207N1	3 1/4	11.024	2.835	3.110	1.299	9 1/8	1 7/8	6.535	5.197	4.843	-	0.591	1 1/8	1/2	4
SPA2215-208N1	3 1/4	11.024	2.835	3.110	1.299	9 1/8	1 7/8	6.535	5.197	4.843	0.709	-	1 1/8	5/8	2
FSPA2215-208N1	3 1/4	11.024	2.835	3.110	1.299	9 1/8	1 7/8	6.535	5.197	4.843	-	0.591	1 1/8	1/2	4
SPA2215N1	3 1/4	11.024	2.835	3.110	1.299	9 1/8	1 7/8	6.535	5.197	4.843	0.709	-	1 1/8	5/8	2
FSPA2215N	3 1/4	11.024	2.835	3.110	1.299	9 1/8	1 7/8	6.535	5.197	4.843	-	0.591	1 1/8	1/2	4
SPA2217-215N1	3 3/4	12.598	3.150	3.504	1.260	10 7/16	2 1/8	7.559	6.142	5.748	0.866	-	1 5/16	3/4	2
FSPA2217-215N1	3 3/4	12.598	3.150	3.504	1.260	10 7/16	2 1/8	7.559	6.142	5.748	-	0.709	1 5/16	5/8	4
SPA2217N1	3 3/4	12.598	3.150	3.504	1.260	10 7/16	2 1/8	7.559	6.142	5.748	0.866	-	1 5/16	3/4	2
FSPA2217N1	3 3/4	12.598	3.150	3.504	1.260	10 7/16	2 1/8	7.559	6.142	5.748	-	0.709	1 5/16	5/8	4
SPA2217-300N1	3 3/4	12.598	3.150	3.504	1.260	10 7/16	2 1/8	7.559	6.142	5.748	0.866	-	1 5/16	3/4	2
FSPA2217-300N1	3 3/4	12.598	3.150	3.504	1.260	10 7/16	2 1/8	7.559	6.142	5.748	-	0.709	1 5/16	5/8	4
SPA2220-307N1	4 1/2	14.961	3.740	4.331	1.654	12 3/8	2 3/8	8.976	7.283	6.890	1.024	-	1 5/8	7/8	2
FSPA2220-307N1	4 1/2	14.961	3.740	4.331	1.654	12 3/8	2 3/8	8.976	7.283	6.890	-	0.866	1 5/8	3/4	4
SPA2220-308N1	4 1/2	14.961	3.740	4.331	1.654	12 3/8	2 3/8	8.976	7.283	6.890	1.024	-	1 5/8	7/8	2
FSPA2220-308N1	4 1/2	14.961	3.740	4.331	1.654	12 3/8	2 3/8	8.976	7.283	6.890	-	0.866	1 5/8	3/4	4
SPA2220N1	4 1/2	14.961	3.740	4.331	1.654	12 3/8	2 3/8	8.976	7.283	6.890	1.024	-	1 5/8	7/8	2
FSPA2220N1	4 1/2	14.961	3.740	4.331	1.654	12 3/8	2 3/8	8.976	7.283	6.890	-	0.866	1 5/8	3/4	4
SPA2222N1	4 15/16	16.496	3.937	4.764	1.772	13 9/16	2 3/4	10.315	7.795	7.283	-	0.866	1 11/16	3/4	4
SPA2222-315N1	4 15/16	16.496	3.937	4.764	1.772	13 9/16	2 3/4	10.315	7.795	7.283	-	0.866	1 11/16	3/4	4
SPA2222-400N1	4 15/16	16.496	3.937	4.764	1.772	13 9/16	2 3/4	10.315	7.795	7.283	-	0.866	1 11/16	3/4	4
SPA2224-403N1	5 1/4	16.496	4.134	4.764	1.496	13 7/8	2 3/4	10.512	7.992	7.480	-	0.866	1 3/8	3/4	4
SPA2224-404N1	5 1/4	16.496	4.134	4.764	1.496	13 7/8	2 3/4	10.512	7.992	7.480	-	0.866	1 3/8	3/4	4
SPA2224N1	5 1/4	16.496	4.134	4.764	1.496	13 7/8	2 3/4	10.512	7.992	7.480	-	0.866	1 3/8	3/4	4
SPA2226-407N1	6	18.386	4.528	5.118	2.047	15 5/16	3 1/4	11.614	8.622	8.110	-	0.945	1 9/16	7/8	4
SPA2226-408N1	6	18.386	4.528	5.118	2.047	15 5/16	3 1/4	11.614	8.622	8.110	-	0.945	1 9/16	7/8	4
SPA2226N1	6	18.386	4.528	5.118	2.047	15 5/16	3 1/4	11.614	8.622	8.110	-	0.945	1 9/16	7/8	4
SPA2228N1	6	20.118	4.724	5.866	2.047	16 9/16	3 3/8	12.087	9.134	8.622	-	1.024	1 9/16	1	4
SPA2228-415N1	6	20.118	4.724	5.866	2.047	16 9/16	3 3/8	12.087	9.134	8.622	-	1.024	1 9/16	1	4
SPA2228-500N1	6	20.118	4.724	5.866	2.047	16 9/16	3 3/8	12.087	9.134	8.622	-	1.024	1 9/16	1	4
SPA2232-507N1	6 11/16	22.008	5.315	6.260	2.362	18 5/16	3 3/4	13.386	10.236	9.724	-	1.024	1 15/16	1	4
SPA2232-508N1	6 11/16	22.008	5.315	6.260	2.362	18 5/16	3 3/4	13.386	10.236	9.724	-	1.024	1 15/16	1	4
SPA2232N1	6 11/16	22.008	5.315	6.260	2.362	18 5/16	3 3/4	13.386	10.236	9.724	-	1.024	1 15/16	1	4

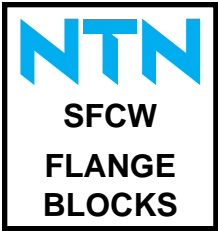

Units: Millimeters
INCHES

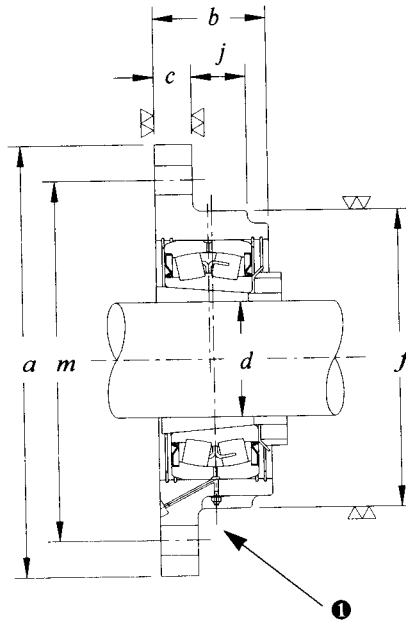
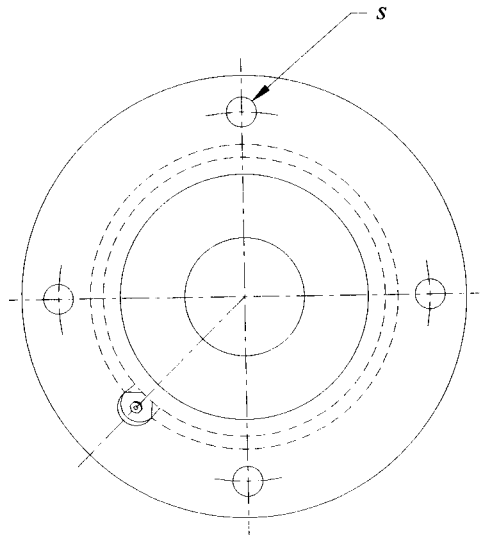

SFCW22...

SFCW FLANGE BLOCKS

Shaft Diameter <i>d</i> Inches	Complete Flange Block Number	Flange Block Housing	Bearing Number	Basic Load Ratings (lbs)		Adaptaer Locknut and Lockwasher	Weight (lbs)
				<i>Dynamic C</i>	<i>Static Co</i>		
1 15/16 50 2	SFCW2211-115N1 SFCW2211N1 SFCW2211-200N1	SFC211N1 SFC211N1 SFC211N1	MX-W22211BLLKC3 MX-W22211BLLKC3 MX-W22211BLLKC3	21,000 21,000 21,000	24,700 24,700 24,700	HA2311M1 H2311XM1 HE2311XYM1	19 19 19
2 3/16 2 1/4 60 2 3/8	SFCW2213-203N1 SFCW2213-204N1 SFCW2213N1 SFCW2213-206N1	SFC213N1 SFC213N1 SFC213N1 SFC213N1	MX-W22213BLLKC3 MX-W22213BLLKC3 MX-W22213BLLKC3 MX-W22213BLLKC3	32,000 32,000 32,000 32,000	40,000 40,000 40,000 40,000	HA2313M1 HE2313XM1 H2313XM1 HS2313XM1	23 23 23 23
2 7/16 2 1/8 65 SFCW2215N1	SFCW2215-207N1 SFCW2215-208N1 SFCW2215N1	SFC215N1 SFC215N1 SFC215N1	MX-W22215BLLKC3 MX-W22215BLLKC3 MX-W22215BLLKC3	37,500 37,500 37,500	50,000 50,000 50,000	HA2315M1 HE2315XM1 H2315XM1	27 27 27
2 15/16 75 3	SFCW2217-216N1 SFCW2217N1 SFCW2217-300N1	SFC217N1 SFC217N1 SFC217N1	MX-W22217BLLKC3 MX-W22217BLLKC3 MX-W22217BLLKC3	46,500 46,500 46,500	61,000 61,000 61,000	HA2317XM1 H2317XM1 HE2317XM1	34 34 34
3 7/16 3 1/2 90 SFCW2220N1	SFCW2220-307N1 SFCW2220-308N1 SFCW2220N1	SFC220N1 SFC220N1 SFC220N1	MX-W22220BLLKC3 MX-W22220BLLKC3 MX-W22220BLLKC3	69,500 69,500 69,500	92,000 92,000 92,000	HA2320M1 HE2320XM1 H2320XM1	61 61 61
3 15/16 4 100 SFCW2222N1	SFCW2222-315N1 SFCW2222-400N1	SFC222N1 SFC222N1	MX-W22222BLLKC3 MX-W22222BLLKC3	92,000 92,000	128,000 128,000	H2322XM1 HA2322M1 HE2322XM1	82 82 82
4 3/16 4 1/4 110 SFCW2224N1	SFCW2224-403N1 SFCW2224-404N1 SFCW2224N1	SFC224N1 SFC224N1 SFC224N1	MX-W22224BLLKC3 MX-W22224BLLKC3 MX-W22224BLLKC3	109,000 109,000 109,000	157,000 157,000 157,000	HA2324M1 HE2324M1 H2324XM1	— — —
4 7/16 4 1/2 115 SFCW2226N1	SFCW2226-407N1 SFCW2226-408N1 SFCW2226N1	SFC226N1 SFC226N1 SFC226N1	MX-W22226BLLKC3 MX-W22226BLLKC3 MX-W22226BLLKC3	127,000 127,000 127,000	176,000 176,000 176,000	HA2326M1 HE2326M1 H2326M1	112 112 112
4 15/16 5 125 SFCW2228N1	SFCW2228-415N1 SFCW2228-500N1	SFC228N1 SFC228N1	MX-W22228BLLKC3 MX-W22228BLLKC3	153,000 153,000	218,000 218,000	H2328M1 HA2328M1 HE2328M1	— — —
5 7/16 5 1/2 140 SFCW2232N1	SFCW2232-507N1 SFCW2232-508N1 SFCW2232N1	SFC232N1 SFC232N1 SFC232N1	MX-W22232BLLKC3 MX-W22232BLLKC3 MX-W22232BLLKC3	196,000 196,000 196,000	290,000 290,000 290,000	HA2332M1 HE2332M1 H2332M1	— — —



How to Order

Example: When you order one SFCW2220N1, you will receive an assembly consisting of one SFC220N1 Flange Block Housing, one MX-W2220BLLKC3 Bearing, and one H2320XM1 Adapter.

When C-SFCW2220N1 or CM-SFCW2220N1 are specified, external covers will be supplied with the unit.

Example: "C" prefix - 1 taconite service seal (dimension *l*)

"CM" prefix - 1 end cover (dimension *l*₁)

Notes: Taconite service seals for which dimensions are shown are standard. For dimensions and availability of non-standard taconite service seals, consult NTN Engineering.

All units are supplied in float arrangement and may be converted to fixed by relocation of a snap ring.

All bearing inserts are supplied prelubricated with Shell Alvania™ 3 grease.

Grease fittings are provided with all units.

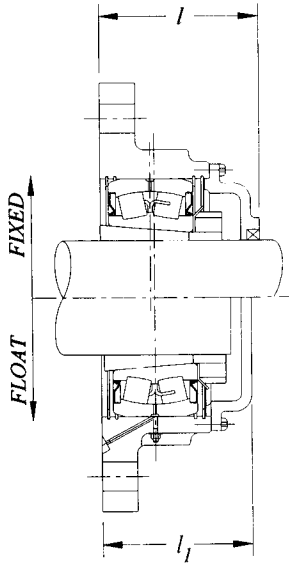

C(M)-SFCW22...

SFCW FLANGE BLOCKS									
Complete Flange Block Number	Dimensions (Millimeters)								
	<i>a</i>	<i>b</i>	<i>c</i>	<i>m</i>	<i>f</i>	<i>j</i>	<i>l</i>	<i>l</i> ₁	<i>s</i>
SFCW2211-115N1	200	62	19	165	130	25	91	85	14
SFCW2211N1	200	62	19	165	130	25	—	—	14
SFCW2211-200N1	200	62	19	165	130	25	—	—	14
SFCW2213-203N1	240	70	24	190	155	25	104	92	14
SFCW2213-204N1	240	70	24	190	155	25	—	—	14
SFCW2213N1	240	70	24	190	155	25	—	—	14
SFCW2213-206N1	240	70	24	190	155	25	—	—	14
SFCW2215-207N1	255	72	24	215	170	32	102	93	17
SFCW2215-208N1	255	72	24	215	170	32	—	—	17
SFCW2215N1	255	72	24	215	170	32	—	—	17
SFCW2217-216N1	270	80	27	240	190	32	118	108	17
SFCW2217N1	270	80	27	240	190	32	—	—	17
SFCW2217-300N1	270	80	27	240	190	32	—	—	17
SFCW2220-307N1	330	95	29	280	230	38	140	130	20
SFCW2220-308N1	330	95	29	280	230	38	—	—	20
SFCW2220N1	330	95	29	280	230	38	—	—	20
SFCW2222N1	365	100	32	310	255	42	—	—	20
SFCW2222-315N1	365	100	32	310	255	42	149	136	20
SFCW2222-400N1	365	100	32	310	255	42	—	—	20
SFCW2224-403N1	400	105	32	330	275	42	154	141	23
SFCW2224-404N1	400	105	32	330	275	42	—	—	23
SFCW2224N1	400	105	32	330	275	42	—	—	23
SFCW2226-407N1	416	115	32	355	290	42	167	154	23
SFCW2226-408N1	416	115	32	355	290	42	—	—	23
SFCW2226N1	416	115	32	355	290	42	—	—	23
SFCW2228N1	450	120	45	385	310	56	—	—	35
SFCW2228-415N1	450	120	45	385	310	56	174	163	35
SFCW2228-500N1	450	120	45	385	310	56	—	—	35
SFCW2232-507N1	520	135	45	435	360	65	195	185	35
SFCW2232-508N1	520	135	45	435	360	65	—	—	35
SFCW2232N1	520	135	45	435	360	65	—	—	35

NTN

**SERIES
SAF 225
SAF 226**

**ADAPTER
MOUNTING**

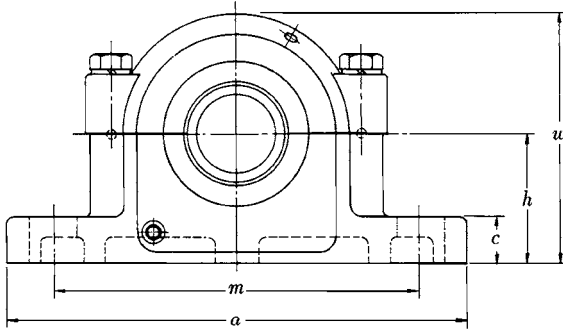

SAF PILLOW BLOCKS

Shaft Diameter d_1 Inches	Complete Pillow Block Number	Pillow Block Housing	Bearing Number	PILLOW BLOCK COMPONENT NUMBERS		Adapter Locknut and Lockwasher	Triple Seal Ring (2 required)	Stabilizing Ring (1 required)
				Basic Load Ratings (lbs)				
				Dynamic C	Static C_o			
1 7/16	SAF22509	SAF509	22209CKD1	18,600	21,400	SNW09	LER17	SR 85X6
1 11/16	SAF22510	SAF510	22210CKD1	19,300	23,000	SNW10	LER20	SR 90X6.5
1 15/16	SAF22511	SAF511	22211BKD1	21,000	24,700	SNW11	LER24	SR100X6
2 3/16	SAF22513	SAF513	22213BKD1	32,000	40,500	SNW13	LER29	SR120X10
2 7/16	SAF22515	SAF515	22215BKD1	37,000	50,000	SNW15	LER37	SR130X10
2 11/16	SAF22516	SAF516	22216BKD1	40,500	53,500	SNW16	LER44	SR140X10
2 15/16	SAF22517	SAF517	22217BKD1	46,500	61,500	SNW17	LER53	SR150X10
3 3/16	SAF22518	SAF518	22218BKD1	57,500	77,500	SNW18	LER69	SR160X10
3 7/16	SAF22520	SAF520	22220BKD1	70,000	92,500	SNW20	LER102	SR180X10
3 15/16	SAF22522	SAF522	22222BKD1	92,500	128,000	SNW22	LER109	SR200X10
4 3/16	SAF22524	SAF524	22224BKD1	109,000	158,000	SNW24	LER113	SR215X10
4 7/16	SAF22526	SAF526	22226BKD1	127,000	176,000	SNW26	LER117	SR230X10
4 15/16	SAF22528	SAF528	22228BKD1	153,000	218,000	SNW28	LER122	SR250X10
5 3/16	SAF22530	SAF530	22230BKD1	174,000	262,000	SNW30	LER125	SR270X10
5 7/16	SAF22532	SAF532	22232BKD1	195,000	290,000	SNW32	LER130	SR290X10
5 15/16	SAF22534	SAF534	22234BKD1	225,000	340,000	SNW34	LER140	SR310X10
6 7/16	SAF22536	SAF536	22236BK	233,000	360,000	SNW36	LER148	SR320X10
6 15/16	SAF22538	SAF538	22238BK	260,000	410,000	SNW38	LER155	SR340X10
7 3/16	SAF22540	SAF540	22240BK	295,000	450,000	SNW40	LER159	SR360X10
7 15/16	SAF22544	SAF544	22244BK	350,000	545,000	SNW44	LER167	SR400X10

SAF PILLOW BLOCKS

Shaft Diameter d_1 Inches	Complete Pillow Block Number	Pillow Block Housing	Bearing Number	PILLOW BLOCK COMPONENT NUMBERS		Adapter Locknut and Lockwasher	Triple Seal Ring (2 required)	Stabilizing Ring (1 required)
				Basic Load Ratings (lbs)				
				Dynamic C	Static C_o			
1 7/16	SAF22609	SAF609	22309CKD1	33,000	37,500	SNW109	LER17	SR100X6
1 11/16	SAF22610	SAF610	22310CKD1	42,000	47,500	SNW110	LER20	SR110X8
1 15/16	SAF22611	SAF611	22311BKD1	46,000	52,500	SNW111	LER24	SR120X10
2 3/16	SAF22613	SAF613	22313BKD1	59,500	71,000	SNW113	LER32	SR140X8.5
2 7/16	SAF22615	SAF615	22315BKD1	74,000	92,000	SNW115	LER37	SR160X10
2 11/16	SAF22616	SAF616	22316BKD1	86,000	105,000	SNW116	LER44	SR170X10
2 15/16	SAF22617	SAF617	22317BKD1	93,500	115,000	SNW117	LER184	SR180X10
3 3/16	SAF22618	SAF618	22318BKD1	107,000	132,000	SNW118	LER188	SR190X9.5
3 7/16	SAF22620	SAF620	22320BKD1	136,000	169,000	SNW120	LER102	SR215X9.5
3 15/16	SAF22622	SAF622	22322BKD1	167,000	209,000	SNW122	LER109	SR240X9.5
4 3/16	SAF22624	SAF624	22324BKD1	198,000	252,000	SNW124	LER113	SR260X9.5
4 7/16	SAF22626	SAF626	22326BKD1	221,000	282,000	SNW126	LER117	SR280X9.5
4 15/16	SAF22628	SAF628	22328BKD1	250,000	320,000	SNW128	LER122	SR300X9.5
5 3/16	SAF22630	SAF630	22330BK	281,000	385,000	SNW130	LER125	SR320X9.5
5 7/16	SAF22632	SAF632	22332BK	315,000	440,000	SNW132	LER130	SR340X9.5
5 15/16	SAF22634	SAF634	22334BK	340,000	480,000	SNW134	LER140	SR360X10
6 7/16	SAF22636	SAF636	22336BK	385,000	565,000	SNW136	LER148	SR380X10
6 15/16	SAF22638	SAF638	22338BK	415,000	615,000	SNW138	LER155	SR400X10



HOW TO ORDER

Example: When you order one SAF22520, you will receive a package containing one SAF520 Pillow Block Housing, one No. 22220BKD1 Bearing and one SNW20 Adapter. All units are supplied with two Triple Seal Rings and a Stabilizing Ring. If you specify SAF22520M3, the required end cover will be included. Always specify shaft size. The same example applies when you order SAF22620.

A pillow block housing number includes one housing and two triple seal rings automatically. Suffix G on a pillow block housing number means one stabilizing ring is also included.

NOTE: For cast steel pillow blocks in 22500(22200) Series (SAFS), see pages 150 and 151.

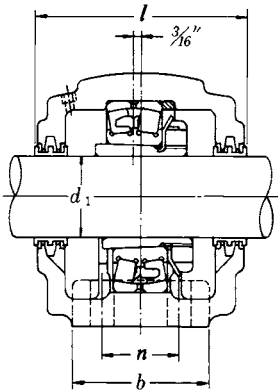

SAF PILLOW BLOCKS											
Complete Pillow Block Number	Dimensions (Inches)									Set Bolts	
	h	a	b	c	m		n	w	l	Size	Number
					max.	min.					
SAF22509	2 1/4	8 1/4	2 3/8	1 3/16	7	6 1/4	—	4 3/8	3 5/8	1/2	2
SAF22510	2 1/2	8 1/4	2 3/8	1 5/16	7	6 1/2	—	4 3/4	3 5/8	1/2	2
SAF22511	2 3/4	9 5/8	2 3/4	1 5/16	7 7/8	7 3/8	—	5 1/4	3 7/8	5/8	2
SAF22513	3	11	3 1/8	1	9 1/2	8 1/8	—	5 15/16	4 1/2	5/8	2
SAF22515	3 1/4	11 1/4	3 1/8	1 1/8	9 5/8	8 5/8	—	6 3/8	4 3/4	5/8	2
SAF22516	3 1/2	13	3 1/2	1 3/16	11	9 5/8	—	6 7/8	4 7/8	3/4	2
SAF22517	3 3/4	13	3 1/2	1 1/4	11	9 7/8	—	7 5/16	5	3/4	2
SAF22518	4	13 3/4	3 7/8	1 5/16	11 5/8	10 3/8	—	7 3/4	5 3/4	3/4	2
SAF22520	4 1/2	15 1/4	4 3/8	1 3/4	13 1/8	11 5/8	—	8 3/4	6	7/8	2
SAF22522	4 15/16	16 1/2	4 3/4	2	14 1/2	12 5/8	2 3/4	9 5/8	6 1/2	3/4	4
SAF22524	5 1/4	16 1/2	4 3/4	2 1/8	14 1/2	13 1/4	2 3/4	10 1/4	7 3/8	3/4	4
SAF22526	6	18 3/8	5 1/8	2 3/8	16	14 5/8	3 1/4	11 1/2	8	7/8	4
SAF22528	6	20 1/8	5 7/8	2 3/8	17 1/8	16	3 3/8	11 3/4	7 5/8	1	4
SAF22530	6 5/16	21 1/4	6 1/4	2 1/2	18 1/4	17	3 3/4	12 1/2	8 3/8	1	4
SAF22532	6 1 1/16	22	6 1/4	2 5/8	19 1/4	17 3/8	3 3/4	13 5/16	8 3/4	1	4
SAF22534	7 1/16	24 3/4	6 3/4	2 3/4	21 5/8	19 3/8	4 1/4	14 3/16	9 5/8	1	4
SAF22536	7 1/2	26 3/4	7 1/8	3	23 5/8	20 7/8	4 5/8	14 7/8	10	1	4
SAF22538	7 7/8	28	7 1/2	3 1/8	24 3/8	21 5/8	4 1/2	15 1 1/16	10 3/4	1 1/4	4
SAF22540	8 1/4	29 1/2	8	3 3/8	25	22 1/2	5	16 1/2	11 1/4	1 1/4	4
SAF22544	9 1/2	32 3/4	8 3/4	3 3/4	27 7/8	24 3/4	5 1/4	18 5/8	12	1 1/2	4

SAF PILLOW BLOCKS											
Complete Pillow Block Number	Dimensions (Inches)									Set Bolts	
	h	a	b	c	m		n	w	l	Size	Number
					max.	min.					
SAF22609	2 3/4	9 5/8	2 3/4	1	7 7/8	7 3/8	—	5 5/16	4 1/4	5/8	2
SAF22610	3	10 5/8	2 3/4	1 1/8	9	7 3/4	—	5 13/16	4 5/8	5/8	2
SAF22611	3 1/4	11	3 1/8	1 3/16	9 1/2	8 1/8	—	6 3/16	4 7/8	5/8	2
SAF22613	3 1/2	13	3 1/2	1 1/4	11	9 5/8	—	6 15/16	5 3/8	3/4	2
SAF22615	4	13 3/4	3 7/8	1 5/16	11 5/8	10 3/8	—	7 13/16	6 1/4	3/4	2
SAF22616	4 1/4	14 1/4	3 7/8	1 5/16	12 5/8	10 5/8	—	8 1/4	6 1/2	3/4	2
SAF22617	4 1/2	15 1/4	4 3/8	1 3/4	13 1/8	11 5/8	—	8 3/4	6 3/4	7/8	2
SAF22618	4 3/4	15 1/2	4 3/8	2	13 1/2	12	2 1/4	9 3/16	6 7/8	3/4	4
SAF22620	5 1/4	16 1/2	4 3/4	2 1/8	14 1/2	13 1/4	2 3/4	10 1/4	7 3/8	3/4	4
SAF22622	6	18 3/8	5 1/8	2 3/8	16	14 5/8	3 1/4	11 1/2	8	7/8	4
SAF22624	6 5/16	21 1/4	6 1/4	2 1/2	18 1/4	17	3 3/4	12 1/2	8 3/8	1	4
SAF22626	6 1 1/16	22	6 1/4	2 5/8	19 1/4	17 3/8	3 3/4	13 5/16	8 3/4	1	4
SAF22628	7 1/16	24 3/4	6 3/4	2 3/4	21 5/8	19 3/8	4 1/4	14 3/16	9 3/8	1	4
SAF22630	7 1/2	26 3/4	7 1/8	3	23 5/8	20 7/8	4 5/8	14 7/8	9 3/4	1	4
SAF22632	7 7/8	28	7 1/2	3 1/8	24 3/8	21 5/8	4 1/2	15 1 1/16	10 5/8	1 1/4	4
SAF22634	8 1/4	29 1/2	8	3 3/8	25	22 1/2	5	16 1/2	11 1/4	1 1/4	4
SAF22636	8 7/8	31 1/4	8 1/4	3 1/2	26 5/8	24	5 1/4	17 3/4	11 3/8	1 1/4	4
SAF22638	9 1/2	32 3/4	8 3/4	3 3/4	27 7/8	24 3/4	5 1/4	18 5/8	12	1 1/2	4



**SERIES
SAF222
SAF223**

**CYLINDRICAL
BORE
MOUNTING**

Units: **Millimeters**
INCHES

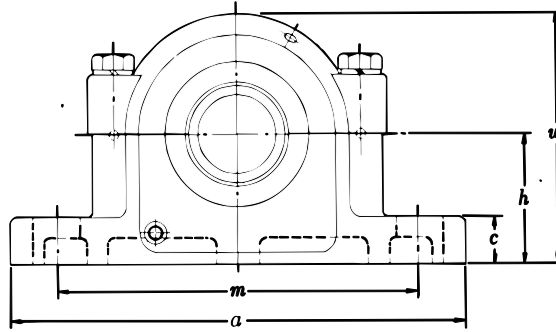

SAF PILLOW BLOCKS

Shaft Diameter Inches		Complete Pillow Block Number	Pillow Block Housing	Bearing Number	Basic Load Ratings (lbs)		Locknut	Lock-washer	Triple Seal Ring		Stabilizing Ring (1 required)
d_2	d_1				Dynamic C	Static C_o			d_2 Shaft (1 req'd)	d_1 Shaft (1 req'd)	
3 3/8	3	SAF22216	SAF216	22216BD1	40,500	53,500	AN16A	W16	LER82	LER54	SR140X10
3 15/16	3 3/16	SAF22217	SAF217	22217BD1	46,500	61,500	AN17A	W17	LER89	LER63	SR150X10
4 1/8	3 3/8	SAF22218	SAF218	22218BD1	57,500	77,500	AN18A	W18	LER96	LER72	SR160X10
4 1/2	3 13/16	SAF22220	SAF220	22220BD1	70,000	92,500	AN20A	W20	LER118	LER106	SR180X10
4 7/8	4 3/16	SAF22222	SAF222	22222BD1	92,500	128,000	AN22A	W22	LER121	LER113	SR200X10
5 5/16	4 9/16	SAF22224	SAF224	22224BD1	109,000	158,000	AN24A	W24	LER127	LER119	SR215X10
5 7/8	4 15/16	SAF22226	SAF226	22226BD1	127,000	176,000	AN26A	W26	LER136	LER122	SR230X10
6 1/4	5 5/16	SAF22228	SAF228	22228BD1	153,000	218,000	AN28A	W28	LER144	LER127	SR250X10
6 3/8	5 3/4	SAF22230	SAF230	22230BD1	174,000	262,000	AN30A	W30	LER151	LER134	SR270X10
7	6 1/16	SAF22232	SAF232	22232BD1	195,000	290,000	AN32A	W32	LER156	LER142	SR290X10
7 7/16	6 7/16	SAF22234	SAF234	22234BD1	225,000	340,000	AN34A	W34	LER161	LER148	SR310X10
7 13/16	6 7/8	SAF22236	SAF236	22236B	233,000	360,000	AN36A	W36	LER165	LER154	SR320X10
8 3/8	7 1/4	SAF22238	SAF238	22238B	260,000	410,000	AN38A	W38	LER171	LER160	SR340X10
8 3/4	7 5/8	SAF22240	SAF240	22240B	295,000	450,000	AN40A	W40	LER175	LER164	SR360X10
9 3/16	8 5/16	SAF22244	SAF244	22244B	350,000	545,000	N44	W44	LER179	LER170	SR400X10

SAF PILLOW BLOCKS

Shaft Diameter Inches		Complete Pillow Block Number	Pillow Block Housing	Bearing Number	Basic Load Ratings (lbs)		Locknut	Lock-washer	Triple Seal Ring		Stabilizing Ring (1 required)
d_2	d_1				Dynamic C	Static C_o			d_2 Shaft (1 req'd)	d_1 Shaft (1 req'd)	
1 15/16	1 7/16	SAF22308	SAF308	22308CD1	27,200	28,800	N08	W08	LER24	LER17	SR 90X6.5
2 1/8	1 11/16	SAF22309	SAF309	22309CD1	33,000	37,500	N09	W09	LER28	LER20	SR100X6
2 3/8	1 7/8	SAF22310	SAF310	22310CD1	42,000	47,500	N10	W10	LER35	LER23	SR110X8
2 9/16	2 1/16	SAF22311	SAF311	22311BD1	46,000	52,500	N11	W11	LER40	LER27	SR120X10
2 7/8	2 1/4	SAF22312	SAF312	22312BD1	53,000	60,500	N12	W12	LER47	LER33	SR130X10
3 1/16	2 7/16	SAF22313	SAF313	22313BD1	59,500	71,000	N13	W13	LER55	LER37	SR140X8.5
3 1/4	2 5/8	SAF22314	SAF314	22314BD1	72,500	85,000	N14	W14	LER64	LER43	SR150X10
3 7/16	2 13/16	SAF22315	SAF315	22315BD1	74,000	92,000	AN15A	W15	LER79	LER46	SR160X10
3 5/8	3	SAF22316	SAF316	22316BD1	86,000	105,000	AN16A	W16	LER84	LER60	SR170X10
3 15/16	3 3/16	SAF22317	SAF317	22317BD1	93,500	115,000	AN17A	W17	LER109	LER188	SR180X10
4 1/8	3 3/8	SAF22318	SAF318	22318BD1	107,000	132,000	AN18A	W18	LER112	LER191	SR190X9.5
4 1/2	3 13/16	SAF22320	SAF320	22320BD1	136,000	169,000	AN20A	W20	LER118	LER106	SR215X9.5
4 7/8	4 3/16	SAF22322	SAF322	22322BD1	167,000	209,000	AN22A	W22	LER121	LER113	SR240X9.5
5 5/16	4 9/16	SAF22324	SAF324	22324BD1	198,000	252,000	AN24A	W24	LER127	LER119	SR260X9.5
5 7/8	4 15/16	SAF22326	SAF326	22326BD1	221,000	282,000	AN26A	W26	LER136	LER122	SR280X9.5
6 1/4	5 5/16	SAF22328	SAF328	22328BD1	250,000	320,000	AN28A	W28	LER144	LER127	SR300X9.5
6 3/8	5 3/4	SAF22330	SAF330	22330B	281,000	385,000	AN30A	W30	LER151	LER134	SR320X9.5
7	6 1/16	SAF22332	SAF332	22332B	315,000	440,000	AN32A	W32	LER156	LER142	SR340X9.5
7 7/16	6 7/16	SAF22334	SAF334	22334B	340,000	480,000	AN34A	W34	LER161	LER148	SR360X10
7 13/16	6 7/8	SAF22336	SAF336	22336B	385,000	565,000	AN36A	W36	LER165	LER154	SR380X10
8 3/8	7 1/4	SAF22338	SAF338	22338B	415,000	615,000	AN38A	W38	LER171	LER160	SR400X10

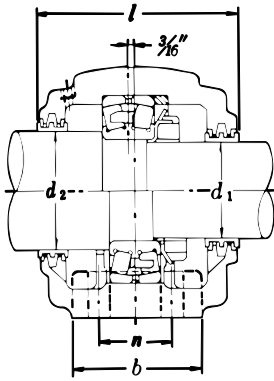

HOW TO ORDER

Example: When you order one SAF22220, you will receive a package containing one SAF220 Pillow Block Housing, one No. 22220BD1 Bearing, one No. AN20A Locknut and one No. W20 Lockwasher. All units are supplied with two Triple Seal Rings and a Stabilizing Ring. If you specify SAF22220M3, the required end cover will be included. Always specify shaft size. The same example applies when you order SAF22320.

A pillow block housing number includes one housing and two triple seal rings automatically. Suffix G on a pillow block housing number means one stabilizing ring is also included.

SAF PILLOW BLOCKS											
Complete Pillow Block Number	Dimensions (Inches)									Set Bolts	
	h	a	b	c	m		n	w	l	Size	Number
					max.	min.					
SAF22216	3 1/2	13	3 1/2	1 1/4	11	9 5/8	—	6 15/16	5 3/8	3/4	2
SAF22217	3 3/4	13	3 1/2	1 1/4	11	9 7/8	—	7 3/8	5 3/8	3/4	2
SAF22218	4	13 3/4	3 7/8	1 5/16	11 5/8	10 3/8	—	7 13/16	6 1/4	3/4	2
SAF22220	4 1/2	15 1/4	4 3/8	1 3/4	13 1/8	11 5/8	—	8 3/4	6	7/8	2
SAF22222	4 15/16	16 1/2	4 3/4	2	14 1/2	12 5/8	2 3/4	9 5/8	6 1/2	3/4	4
SAF22224	5 1/4	16 1/2	4 3/4	2 1/8	14 1/2	13 1/4	2 3/4	10 1/4	7 3/8	3/4	4
SAF22226	6	18 3/8	5 1/8	2 3/8	16	14 5/8	3 1/4	11 1/2	8	7/8	4
SAF22228	6	20 1/8	5 7/8	2 3/8	17 1/8	16	3 3/8	11 3/4	7 5/8	1	4
SAF22230	6 5/16	21 1/4	6 1/4	2 1/2	18 1/4	17	3 3/4	12 1/2	8 3/8	1	4
SAF22232	6 11/16	22	6 1/4	2 5/8	19 1/4	17 3/8	3 3/4	13 5/16	8 3/4	1	4
SAF22234	7 1/16	24 3/4	6 3/4	2 3/4	21 5/8	19 3/8	4 1/4	14 3/16	9 5/8	1	4
SAF22236	7 1/2	26 3/4	7 1/8	3	23 5/8	20 7/8	4 5/8	14 7/8	10	1	4
SAF22238	7 7/8	28	7 1/2	3 1/8	24 3/8	21 5/8	4 1/2	15 11/16	10 3/4	1 1/4	4
SAF22240	8 1/4	29 1/2	8	3 3/8	25	22 1/2	5	16 1/2	11 1/4	1 1/4	4
SAF22244	9 1/2	32 3/4	8 3/4	3 3/4	27 7/8	24 3/4	5 1/4	18 5/8	12	1 1/2	4

SAF PILLOW BLOCKS											
Complete Pillow Block Number	Dimensions (Inches)									Set Bolts	
	h	a	b	c	m		n	w	l	Size	Number
					max.	min.					
SAF22308	2 1/2	8 1/4	2 3/8	1	7	6 1/2	—	4 13/16	4	1/2	2
SAF22309	2 3/4	9 5/8	2 3/4	1	7 7/8	7 3/8	—	5 5/16	4 1/4	5/8	2
SAF22310	3	10 5/8	2 3/4	1 1/8	9	7 3/4	—	5 13/16	4 5/8	5/8	2
SAF22311	3 1/4	11	3 1/8	1 3/16	9 1/2	8 1/8	—	6 3/16	5	5/8	2
SAF22312	3 1/4	11 1/4	3 1/8	1 3/16	9 5/8	8 5/8	—	6 3/8	5 1/4	5/8	2
SAF22313	3 1/2	13	3 1/2	1 1/4	11	9 5/8	—	6 15/16	5 3/8	3/4	2
SAF22314	3 3/4	13	3 1/2	1 1/4	11	9 7/8	—	7 3/8	5 3/8	3/4	2
SAF22315	4	13 3/4	3 7/8	1 5/16	11 5/8	10 3/8	—	7 13/16	6 1/4	3/4	2
SAF22316	4 1/4	14 1/4	3 7/8	1 5/16	12 5/8	10 5/8	—	8 1/4	6 1/2	3/4	2
SAF22317	4 1/2	15 1/4	4 3/8	1 3/4	13 1/8	11 5/8	—	8 3/4	6 3/4	7/8	2
SAF22318	4 3/4	15 1/2	4 3/8	2	13 1/2	12	2 1/4	9 3/16	6 7/8	3/4	4
SAF22320	5 1/4	16 1/2	4 3/4	2 1/8	14 1/2	13 1/4	2 3/4	10 1/4	7 3/8	3/4	4
SAF22322	6	18 3/8	5 1/8	2 3/8	16	14 5/8	3 1/4	11 1/2	8	7/8	4
SAF22324	6 5/16	21 1/4	6 1/4	2 1/2	18 1/4	17	3 3/4	12 1/2	8 3/8	1	4
SAF22326	6 11/16	22	6 1/4	2 5/8	19 1/4	17 3/8	3 3/4	13 5/16	8 3/4	1	4
SAF22328	7 1/16	24 3/4	6 3/4	2 3/4	21 5/8	19 3/8	4 1/4	14 3/16	9 3/8	1	4
SAF22330	7 1/2	26 3/4	7 1/8	3	23 5/8	20 7/8	4 5/8	14 7/8	9 3/4	1	4
SAF22332	7 7/8	28	7 1/2	3 1/8	24 3/8	21 5/8	4 1/2	15 11/16	10 3/4	1 1/4	4
SAF22334	8 1/4	29 1/2	8	3 3/8	25	22 1/2	5	16 1/2	11 1/4	1 1/4	4
SAF22336	8 7/8	31 1/4	8 1/4	3 5/8	26 5/8	24	5 1/4	18 1/2	11 1/4	1 1/4	4
SAF22338	9 1/2	32 3/4	8 3/4	3 3/4	27 7/8	24 3/4	5 1/4	18 5/8	12	1 1/2	4



**SERIES
SAFS225
ADAPTER
MOUNTING**

**SAFS222
CYLINDRICAL
BORE
MOUNTING**

Units: Millimeters
INCHES

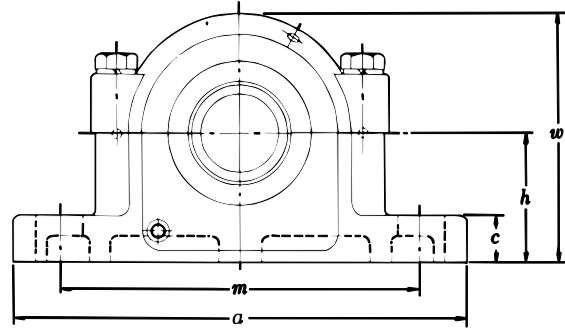
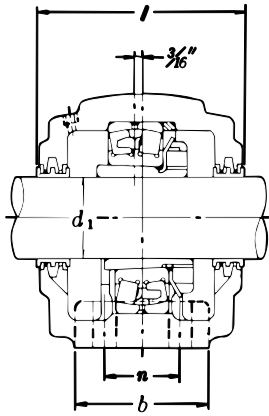

SAFS 225

SAFS PILLOW BLOCKS

Shaft Diameter d_1 Inches	Complete Pillow Block Number	Pillow Block Housing	Bearing Number	PILLOW BLOCK COMPONENT NUMBERS				
				Basic Load Ratings (lbs)		Adapter Locknut and Lockwasher	Triple Seal Ring (2 required)	Stabilizing Ring (1 required)
				Dynamic C	Static C_0			
1 7/16	SAFS22509	SAFS509	22209CKD1	18,600	21,400	SNW09	LER17	SR 85X6
1 11/16	SAFS22510	SAFS510	22210CKD1	19,300	23,000	SNW10	LER20	SR 90X6.5
1 15/16	SAFS22511	SAFS511	22211BKD1	21,000	24,700	SNW11	LER24	SR100X6
2 3/16	SAFS22513	SAFS513	22213BKD1	32,000	40,500	SNW13	LER29	SR120X10
2 7/16	SAFS22515	SAFS515	22215BKD1	37,000	50,000	SNW15	LER37	SR130X10
2 11/16	SAFS22516	SAFS516	22216BKD1	40,500	53,500	SNW16	LER44	SR140X10
2 15/16	SAFS22517	SAFS517	22217BKD1	46,500	61,500	SNW17	LER53	SR150X10
3 3/16	SAFS22518	SAFS518	22218BKD1	57,500	77,500	SNW18	LER69	SR160X10
3 7/16	SAFS22520	SAFS520	22220BKD1	70,000	92,500	SNW20	LER75	SR180X10
3 15/16	SAFS22522	SAFS522	22222BKD1	92,500	128,000	SNW22	LER93	SR200X10
4 3/16	SAFS22524	SAFS524	22224BKD1	109,000	158,000	SNW24	LER113	SR215X10
4 7/16	SAFS22526	SAFS526	22226BKD1	127,000	176,000	SNW26	LER117	SR230X10
4 15/16	SAFS22528	SAFS528	22228BKD1	153,000	218,000	SNW28	LER122	SR250X10
5 3/16	SAFS22530	SAFS530	22230BKD1	174,000	262,000	SNW30	LER125	SR270X10
5 7/16	SAFS22532	SAFS532	22232BKD1	195,000	290,000	SNW32	LER130	SR290X10
5 15/16	SAFS22534	SAFS534	22234BKD1	225,000	340,000	SNW34	LER140	SR310X10
6 7/16	SAFS22536	SAFS536	22236BK	233,000	360,000	SNW36	LER148	SR320X10
6 15/16	SAFS22538	SAFS538	22238BK	260,000	410,000	SNW38	LER224	SR340X10
7 3/16	SAFS22540	SAFS540	22240BK	295,000	450,000	SNW40	LER228	SR360X10
7 15/16	SAFS22544	SAFS544	22244BK	350,000	545,000	SNW44	LER236	SR400X10

SAFS PILLOW BLOCKS

Shaft Diameter Inches		Complete Pillow Block Number	Pillow Block Housing	Bearing Number	PILLOW BLOCK COMPONENT NUMBERS						
					Basic Load Ratings (lbs)		Locknut	Lock-washer	Triple Seal Ring		Stabilizing Ring (1 required)
					Dynamic C	Static C_0			d_2 Shaft (1 req'd)	d_1 Shaft (1 req'd)	
3 5/8	3	SAFS22216	SAFS216	22216BD1	40,500	53,500	AN16A	W16	LER 82	LER 54	SR140X10
3 15/16	3 3/16	SAFS22217	SAFS217	22217BD1	46,500	61,500	AN17A	W17	LER89	LER 63	SR150X10
4 1/8	3 3/8	SAFS22218	SAFS218	22218BD1	57,500	77,500	AN18A	W18	LER96	LER 72	SR160X10
4 1/2	3 13/16	SAFS22220	SAFS220	22220BD1	70,000	92,500	AN20A	W20	LER205	LER 87	SR180X10
4 7/8	4 3/16	SAFS22222	SAFS222	22222BD1	92,500	128,000	AN22A	W22	LER121	LER113	SR200X10
4 9/16	4 9/16	SAFS22224	SAFS224	22224BD1	109,000	158,000	AN24A	W24	LER127	LER119	SR215X10
5 7/8	4 15/16	SAFS22226	SAFS226	22226BD1	127,000	176,000	AN26A	W26	LER136	LER122	SR230X10
6 1/4	5 5/16	SAFS22228	SAFS228	22228BD1	153,000	218,000	AN28A	W28	LER144	LER127	SR250X10
6 5/8	5 3/4	SAFS22230	SAFS230	22230BD1	174,000	262,000	AN30A	W30	LER151	LER134	SR270X10
7	6 1/16	SAFS22232	SAFS232	22232BD1	195,000	290,000	AN32A	W32	LER156	LER142	SR290X10
7 7/16	6 7/16	SAFS22234	SAFS234	22234BD1	225,000	340,000	AN34A	W34	LER161	LER148	SR310X10
7 13/16	6 7/8	SAFS22236	SAFS236	22236B	233,000	360,000	AN36A	W36	LER165	LER154	SR320X10
8 3/8	7 1/4	SAFS22238	SAFS238	22238B	260,000	410,000	AN38A	W38	LER240	LER229	SR340X10
8 3/4	7 5/8	SAFS22240	SAFS240	22240B	295,000	450,000	AN40A	W40	LER244	LER233	SR360X10
9 9/16	8 5/16	SAFS22244	SAFS244	22244B	350,000	545,000	N44	W44	LER248	LER239	SR400X10

HOW TO ORDER

Example No. 1: When you order one SAFS22520, you will receive a package containing one SAFS520 Pillow Block Housing, one No. 22220BKD1 Bearing and one SNW20 Adapter.

Example No. 2: When you order one SAFS22220, you will receive a package containing one SAFS220 Pillow Block Housing, one No. 22220BD1 Bearing, one No. AN20A Locknut and one No. W20 Lockwasher.

For both of the above examples:

All units are supplied with two Triple Seal Rings and a Stabilizing Ring. If you specify SAFS22520M3, the required end cover will be included. Always specify shaft size.

A pillow block housing number includes one housing and two triple seal rings automatically. Suffix G on a pillow block housing number means one stabilizing ring is also included.

Units: **Millimeters**
INCHES

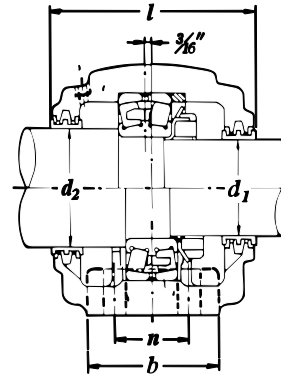

SAFS 222



SAFS PILLOW BLOCKS											
Complete Pillow Block Number	Dimensions (Inches)									Set Bolts	
	<i>h</i>	<i>a</i>	<i>b</i>	<i>c</i>	<i>m</i>		<i>n</i>	<i>w</i>	<i>l</i>	Size	Number
					max.	min.					
SAFS22509	2 1/4	8 1/4	2 3/8	7/8	7	6 1/4	—	4 7/16	3 5/8	1/2	2
SAFS22510	2 1/2	8 1/4	2 3/8	1	7	6 1/2	—	4 13/16	4	1/2	2
SAFS22511	2 3/4	9 5/8	2 3/4	1	7 7/8	7 3/8	—	5 5/16	4 1/4	5/8	2
SAFS22513	3	11	3 1/8	1	9 1/2	8 1/8	—	5 15/16	5	5/8	2
SAFS22515	3 1/4	11 1/4	3 1/8	1 3/16	9 5/8	8 5/8	—	6 3/8	5 1/4	5/8	2
SAFS22516	3 1/2	13	3 1/2	1 1/4	11	9 5/8	—	6 15/16	5 3/8	3/4	2
SAFS22517	3 3/4	13	3 1/2	1 1/4	11	9 7/8	—	7 3/8	5 3/8	3/4	2
SAFS22518	4	13 3/4	3 7/8	1 5/16	11 5/8	10 3/8	—	7 13/16	6 1/4	3/4	2
SAFS22520	4 1/2	15 1/4	4 3/8	1 1/2	13 1/8	11 5/8	—	8 7/8	6 3/4	7/8	2
SAFS22522	4 15/16	16 1/2	4 3/4	1 5/8	14 1/2	12 5/8	2 3/4	9 11/16	7 1/4	3/4	4
SAFS22524	5 1/4	16 1/2	4 3/4	1 3/4	14 1/2	13 1/4	2 3/4	10 1/4	7 3/8	3/4	4
SAFS22526	6	18 3/8	5 1/8	1 7/8	16	14 5/8	3 1/4	11 9/16	8	7/8	4
SAFS22528	6	20 1/8	5 7/8	1 15/16	17 1/8	16	3 3/8	12	7 5/8	1	4
SAFS22530	6 5/16	21 1/4	6 1/4	2	18 1/4	17	3 3/4	12 11/16	8 3/8	1	4
SAFS22532	6 11/16	22	6 1/4	2	19 1/4	17 3/8	3 3/4	13 9/16	8 3/4	1	4
SAFS22534	7 1/16	24 3/4	6 3/4	2 1/8	21 5/8	19 3/8	4 1/4	14 9/16	9 5/8	1	4
SAFS22536	7 1/2	26 3/4	7 1/8	2 1/8	23 5/8	20 7/8	4 5/8	15 5/16	10	1	4
SAFS22538	7 7/8	28	7 1/2	2 3/8	24 3/8	21 5/8	4 1/2	16 3/16	10 5/8	1 1/4	4
SAFS22540	8 1/4	29 1/2	8	2 3/8	25	22 1/2	5	17 3/16	11 1/8	1 1/4	4
SAFS22544	9 1/2	32 3/4	8 3/4	2 3/4	27 7/8	24 3/4	5 1/4	19 7/16	11 7/8	1 1/2	4

SAFS PILLOW BLOCKS											
Complete Pillow Block Number	Dimensions (Inches)									Set Bolts	
	<i>h</i>	<i>a</i>	<i>b</i>	<i>c</i>	<i>m</i>		<i>n</i>	<i>w</i>	<i>l</i>	Size	Number
					max.	min.					
SAFS22216	3 1/2	13	3 1/2	1 1/4	11	9 5/8	—	6 15/16	5 3/8	3/4	2
SAFS22217	3 3/4	13	3 1/2	1 1/4	11	9 7/8	—	7 3/8	5 3/8	3/4	2
SAFS22218	4	13 3/4	3 7/8	1 5/16	11 5/8	10 3/8	—	7 13/16	6 1/4	3/4	2
SAFS22220	4 1/2	15 1/4	4 3/8	1 1/2	13 1/8	11 5/8	—	8 7/8	6 3/4	7/8	2
SAFS22222	4 15/16	16 1/2	4 3/4	1 5/8	14 1/2	12 5/8	2 3/4	9 11/16	7 1/4	3/4	4
SAFS22224	5 1/4	16 1/2	4 3/4	1 3/4	14 1/2	13 1/4	2 3/4	10 1/4	7 3/8	3/4	4
SAFS22226	6	18 3/8	5 1/8	1 7/8	16	14 5/8	3 1/4	11 9/16	8	7/8	4
SAFS22228	6	20 1/8	5 7/8	1 15/16	17 1/8	16	3 3/8	12	7 5/8	1	4
SAFS22230	6 5/16	21 1/4	6 1/4	2	18 1/4	17	3 3/4	12 11/16	8 3/8	1	4
SAFS22232	6 11/16	22	6 1/4	2	19 1/4	17 3/8	3 3/4	13 9/16	8 3/4	1	4
SAFS22234	7 1/16	24 3/4	6 3/4	2 1/8	21 5/8	19 3/8	4 1/4	14 9/16	9 5/8	1	4
SAFS22236	7 1/2	26 3/4	7 1/8	2 1/8	23 5/8	20 7/8	4 5/8	15 5/16	10	1	4
SAFS22238	7 7/8	28	7 1/2	2 3/8	24 3/8	21 5/8	4 1/2	16 3/16	10 5/8	1 1/4	4
SAFS22240	8 1/4	29 1/2	8	2 3/8	25	22 1/2	5	17 3/16	11 1/8	1 1/4	4
SAFS22244	9 1/2	32 3/4	8 3/4	2 3/4	27 7/8	24 3/4	5 1/4	19 7/16	11 7/8	1 1/4	4

NTN Bearings

**TECHNICAL
INFORMATION**



TECHNICAL INFORMATION

Bearing Materials

The reliability and high capacity of NTN ball and roller bearings is the result of developments in metallurgy, manufacturing techniques, and our strict methods of quality control.

Contact surfaces of the bearing rings and rolling elements are subjected to repeated heavy stresses, yet must be able to maintain high precision and rotational accuracy. To accomplish this, the rings and rolling elements must be made of material that has high hardness, is resistant to rolling fatigue, is wear resistant and has good dimensional stability.

High carbon chromium bearing steel, which can be deep hardened, and case hardened steel with a hardened carburized outer layer are used for the rings and rolling elements of standard bearings. Case hardened steels have excellent shock resistance properties and are often used where impact loads are present.

The most common cause of fatigue cracking in bearings is the inclusion of non-metallic impurities in the bearing material. By using clean materials, the rolling fatigue life of the bearing is lengthened. For all its bearings, NTN uses steel of the highest cleanliness, and refined by a vacuum degassing process.

Bearing cage materials must have the strength to withstand rotational vibrations and shock loads. These materials must also have a low friction coefficient, be light weight, and be able to withstand bearing operating temperatures. Common cage materials are low carbon steel, bronze/brass alloy, or injection molded plastic. For additional information, please contact your NTN representative.

Handling & Installation

Improper handling practices prior to and during installation can easily damage the performance and precision built into NTN ball and roller bearings. It is necessary that certain precautions are taken to prevent such damage.

The most important factor to keep in mind when handling bearings is cleanliness. NTN bearings are assembled under immaculate conditions, then carefully packaged for protection against contamination and oxidation. A strong effort should be made to keep the bearings in this condition prior to final assembly. The bearing package should remain closed until ready for immediate installation. If it is necessary to unwrap bearings before that, they should be placed in a clean, dry area. Do not stack unpackaged bearings.

Bearings should be installed in an area where a clean atmosphere exists. Dirty conditions in the bearing installation area can easily lead to contamination and a premature failure. In addition, assembly benches and tools must be kept clean to prevent contaminants such as dust, grit and steel chips from entering the bearing. It is much easier to keep a bearing clean than it is to wash it clean enough for service.

The shaft, housing and other machine elements should be cleaned and inspected prior to bearing installation. The bearing mounting must be properly designed from a functional standpoint, and must have correct shaft and housing fits and shoulder heights. The design should be such that the bearings can be installed as easily as possible.

Proper assembly procedures and tools such as arbor presses, pullers, and sleeves will not only facilitate assembly, but will also avoid damage to the bearings. When a bearing is pressed on a shaft, the inner ring must be started squarely. A "cocked" ring may score the shaft and damage the bearing. The pressure must be applied directly on the ring being mounted. The bearing must not be tapped in place with direct blows on the bearing ring. The preferred practice is to place a sleeve between the bearing ring and the hammer and to tap the sleeve lightly all around. (Illustration A)

Sometimes a larger size bearing must be heated so that it can be more easily assembled on a shaft. A convenient method of doing this is to insert a heat source

such as a light bulb in the bore of the bearing, avoiding direct contact until the inner ring has expanded sufficiently. Another method is to heat the bearing in a bath of hot oil. The oil must be clean, and the temperature should not exceed 250° F. Higher temperatures may cause the oil to decompose and the bearing to lose its proper hardness.

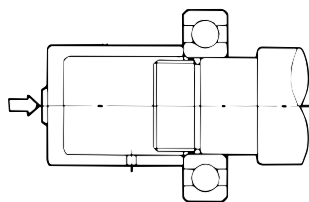

Fig. 15.1 Press mounting of inner ring

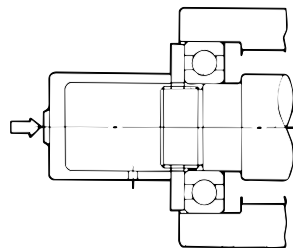

Fig. 15.2 Press mounting of inner and outer rings simultaneously

Illustration A

Running Test

After mounting, a running test should be performed to ensure that the bearing has been properly installed. The shaft or housing is first rotated by hand. If no problems are observed, a low speed, no load power test is performed. If no abnormalities are detected at this point, the load and speed are gradually increased to operating conditions. If any unusual noise, vibration or temperature rise is observed during the test, the procedure should be stopped and the installation examined.

Under normal conditions, bearing temperature rises with rotation and then reaches a stable operating temperature. If the temperature continues to rise and does not level off, or if there is a sudden temperature rise, or if the temperature is unusually high, the bearing should be inspected.

Dismounting

Bearings are often removed as part of periodic inspection procedures, or during the replacement of other parts. The shaft and housing are almost always reinstalled, and the bearings themselves are often reused. Because of this, the same guidelines for cleanliness in mounting apply to dismounting. (Illustration B)

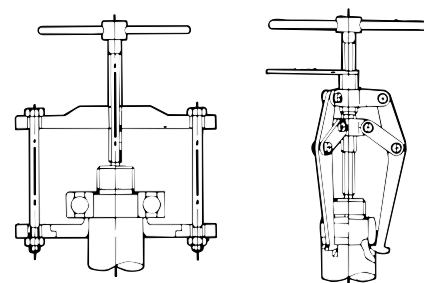

Fig. 15.12 Puller dismounting

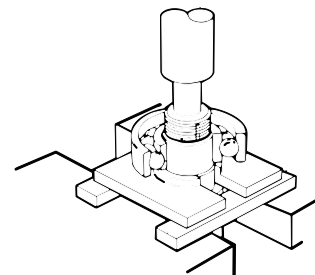

Fig. 15.13 Press dismounting

Illustration B



TECHNICAL INFORMATION

Lubrication

Bearing lubricants are of two basic types: oil or grease. The purpose of bearing lubrication is to prevent direct metal to metal contact between the various rolling and sliding elements. This is accomplished through the formation of a thin film on the contact surfaces, and is necessary for the following reasons:

- Friction and wear reduction
- Dissipation of heat generated within the bearing
- Prolonged bearing life
- Prevention of rust
- Protection from foreign material entering bearing

Grease lubricants are composed of either a mineral oil base or a synthetic oil base combined with a thicken-

ing agent. Grease type lubricants are relatively easy to handle, and require only the simplest sealing devices. A suitable grease should remain mechanically and chemically stable at operating temperature. It should not thicken, harden, separate, or become acid or alkaline to any marked degree.

Oil consists of either petroleum fluids refined from crude oil or synthetic fluids produced by chemical synthesis. Generally, oil lubrication is better suited for high speed and high temperature applications than grease lubrication. Oil lubrication is especially effective for those applications requiring the bearing generated heat (or heat applied to the bearing from other sources) to be dissipated. For additional lubrication information, please contact your NTN representative.

COMMON GREASE CODES AND NAMES

NTN Code	Brand	Military Specs.	Temp. Range	Thickener	Oil
2AS	Shell Alvania 2S	MIL-G-18709A	-30° F to +230° F	Lithium	Petroleum
9B	Mobil 28	MIL-G-81322	-80° F to +350° F	Synthetic	Synthetic
5C	Chevron SRI-2	MIL-G-3545C	-20° F to +350° F	Polyurea	Petroleum
1D	LX40 (DuPont Krytox 240AB)	MIL-G-38220	-40° F to +450° F	Fluorotelomer	Fluorotelomer
1E	Exxon Andok C	—	-30° F to +250° F	Sodium	Petroleum
4E	Exxon Andok 260	MIL-G-3545	-20° F to +275° F	Sodium	Petroleum
4M	Dow-Corning DC 44M	MIL-G-15719A	-40° F to +400° F	Lithium	Silicone
5S	Shell Aero Shell 7	MIL-G-23827A	-100° F to +250° F	Microgel	Diester
3W	Texaco Regal AFB 2	MIL-G-24139	-30° F to +230° F	Lithium	Petroleum
L627	Exxon Polyrex EM	—	-20° F to +350° F	Polyurea	Mineral
5K	Kyodo Yushi Multemp SRL	—	-40° F to +300° F	Lithium	—

ANALYSIS OF BEARING OPERATING PROBLEMS

The following table lists some common types of bearing operating problems, probable causes, and suggested corrective measures. If these suggestions do not correct the trouble, call your **NTN** Representative for assistance.



TECHNICAL INFORMATION

Trouble	Observed Characteristic	Probable Cause	Corrective Action
NOISE	High pitch, steady tone	Excessive axial load	Correct outer ring fit in housing and/or shoulder location to allow thermal expansion.
		Excessive radial load	Use correct fit of inner ring on shaft. For radial bearings, use bearing with greater internal clearance. For pre-loaded paired bearings, use lighter preload.
		Misalignment	Correct alignment.
	Low pitch, continuous or intermittent	Too much clearance in bearing	Use correct shaft fit. For radial bearings, use bearing with less internal clearance. For preloaded paired bearings, use heavier preload.
		Bearing brinelled	Replace bearing, avoid brinelling.
		Raceways pitted due to dirt	Wash all parts, replace with new bearing, use clean lubricant, improve seals.
		Resonant vibration of machine structure	Stiffen or sound-deaden thin panels and large flat surfaces.
	Intermittent squeal or high pitch noise	Balls skidding	Provide thrust preload spring. Use thinner grease. For radial bearings, use bearing with less internal clearance. For preloaded paired bearings, check for correct preload.
		Shaft rubbing housing	Correct seals and machine parts.
	Intermittent rumbles, rattles, clicks, etc.	Too much clearance in bearing	Correct shaft fit. For radial bearings, use adjusting spring or bearing with less internal clearance. For preloaded paired bearings, check for correct preload.
		Dirt in bearing	Wash all parts, replace with new bearing if necessary, use clean lubricant, improve seals.
		Loose machine parts	Tighten all fans, pulleys, closures, spacers, slingers etc.
TEMPERATURE	High after first start	Grease redistribution	Allow machine to cool. Restart.
	Continuously high during operation	Churning of lubricant	Use lower oil level, less grease, stiffer grease.
		No lubricant	Add lubricant.
		Excessive axial load	Check outer ring fit in housing and/or shoulder location to allow thermal expansion.
		Excessive radial load	Use correct fit of inner ring on shaft. For radial bearings, use bearing with greater internal clearance. For preloaded paired bearings, use lighter preload.
		Bearing misaligned	Correct machine parts and alignment procedures.
		Excessive seal drag	Use different type of seal.



**TECHNICAL
INFORMATION**

Trouble	Observed Characteristic	Probable Cause	Corrective Action
EXCESSIVE VIBRATION	During acceleration or deceleration periods	Critical speeds of machine components	Stiffen shaft or other machine components to avoid critical speeds.
	During operation at fixed speeds	Unbalanced rotating parts	Dynamically balance rotating parts.
		Shaft bent	Straighten and re-balance.
		Cams, gears, linkage	Adjust, improve or redesign.
		Misalignment	Correct machine parts.
		Bearing brinelled	Replace bearing, avoid brinelling.
RUNOUT	Shaft does not run true. Shaft binds when rotated by hand.	Shaft bent	Straighten shaft and re-balance.
		Bearing misaligned	Correct machine parts and alignment procedures.
		Bearing rings out of square	Check squareness of shaft and housing shoulders, spacers and flingers, etc.
		Dirt	Wash all parts, replace with new bearing if necessary, use clean lubricant, improve seals.
		Machine deflection	Stiffen machine members.
INNER RING WEARS LOOSE ON SHAFT	Wear of the shaft seat	Incorrect shaft fit	Use recommended shaft fit.
		Poor shaft finish	Smooth turn or grind shaft to size after metalspraying or chrome plating.
OUTER RING WEARS LOOSE IN HOUSING	Wear in housing bore	Housing fit too loose	Use recommended housing fit.
		Unbalanced forces	Dynamically balance rotating parts. Clamp outer ring faces. Use cylindrical roller bearing and press fit outer and inner rings.
		Poor finish	Bore or grind housing I.D. oversize, press in a bushing and finish bore or grind to size.
		Soft housing material	Use steel liners. Work-harden bore.



**TECHNICAL
INFORMATION
BEARING
NOMENCLATURE**

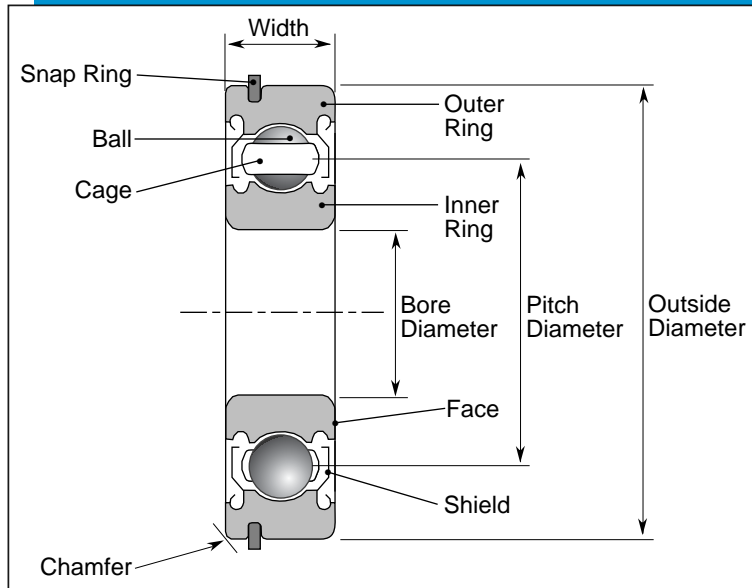

**SINGLE ROW DEEP
GROOVE BALL BEARING**

**SINGLE ROW ANGULAR
CONTACT BALL BEARING**

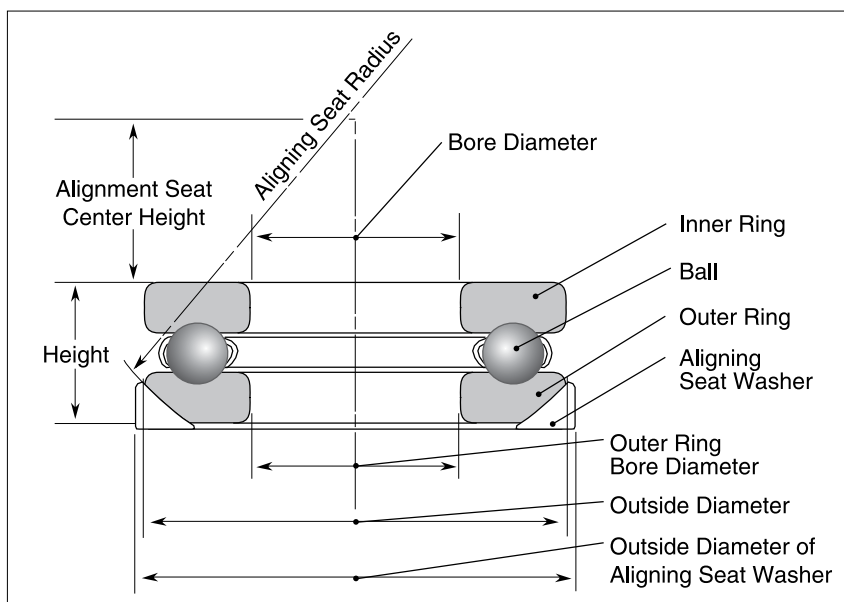
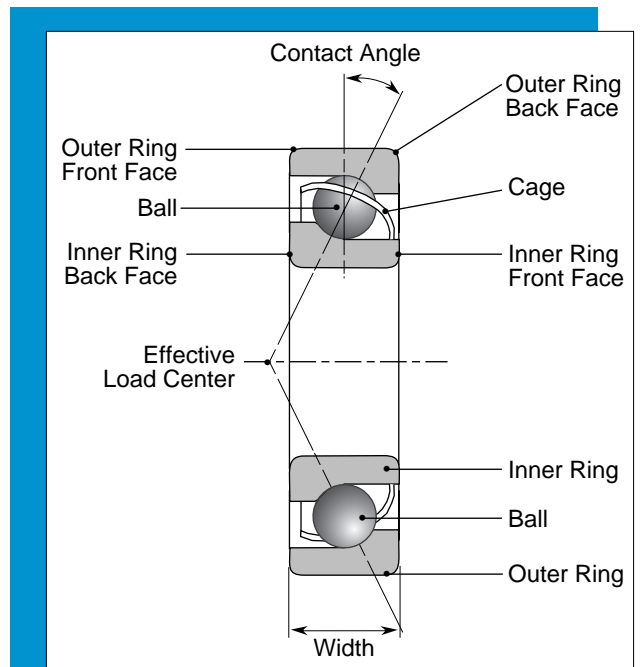

**SINGLE DIRECTION
THRUST BALL BEARING**



**TECHNICAL
INFORMATION
BEARING
NOMENCLATURE**

SPHERICAL ROLLER BEARING

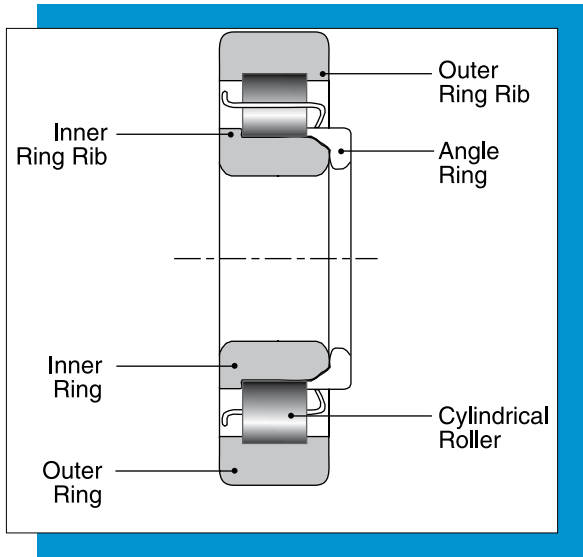
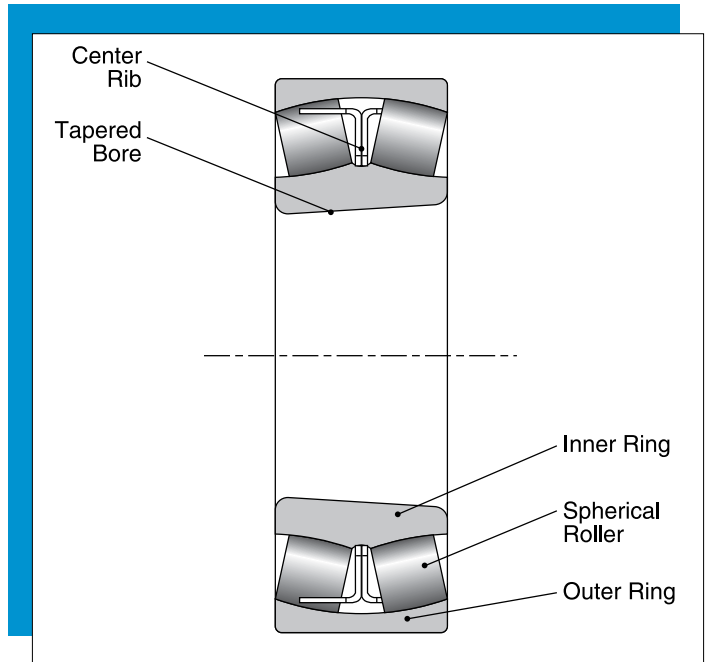

CYLINDRICAL ROLLER BEARING

TAPERED ROLLER BEARING

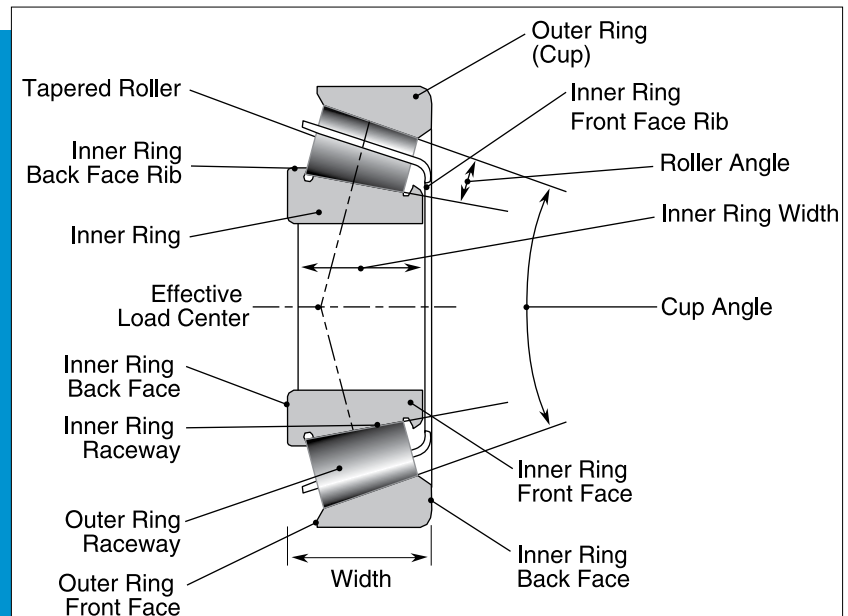

PILLOW BLOCKS

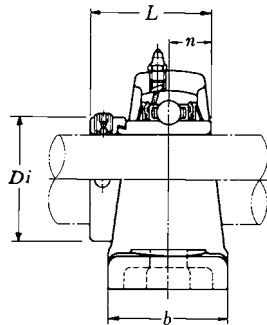
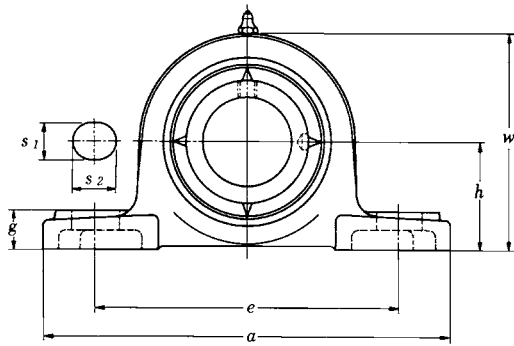

FLANGE UNITS

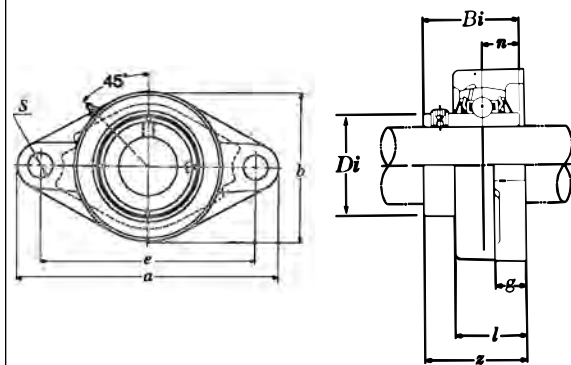
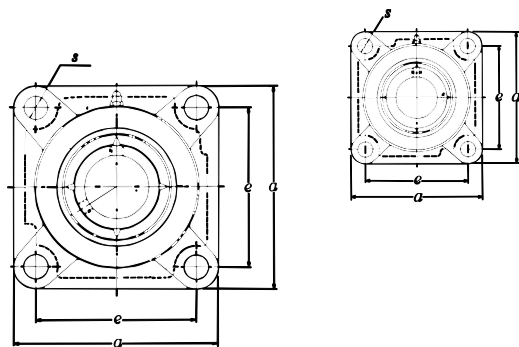

**BEARING UNIT DIMENSION
NOMENCLATURE**

- a = Total housing length
- b = Total housing width – flange units
- e = Bolt hole center-to-center distance
- s_1, s_2 = Bolt hole size, pillow blocks
- s = Bolt hole size, flange units
- Z = Total housing plus bearing depth
- l = Total housing depth – flange units
- i = Bearing ball center to housing rear depth
- N = Bearing ball center to bearing inner ring face
- B_i = Total bearing unit depth – flange units
- g = Flange depth and bolt hole depth
- w = Total bearing unit height – pillow blocks
- h = Bearing unit base to bearing bore center (Center Height) Pillow Blocks



TECHNICAL
INFORMATION
BEARING
NOMENCLATURE

STANDARD GREASE FITTINGS

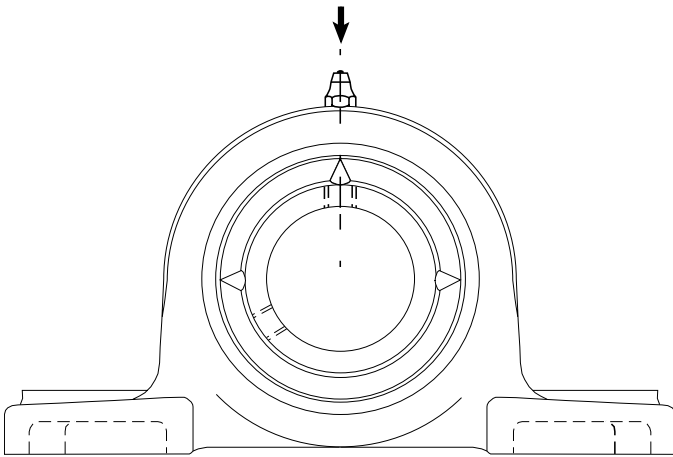

45° GREASE FITTINGS

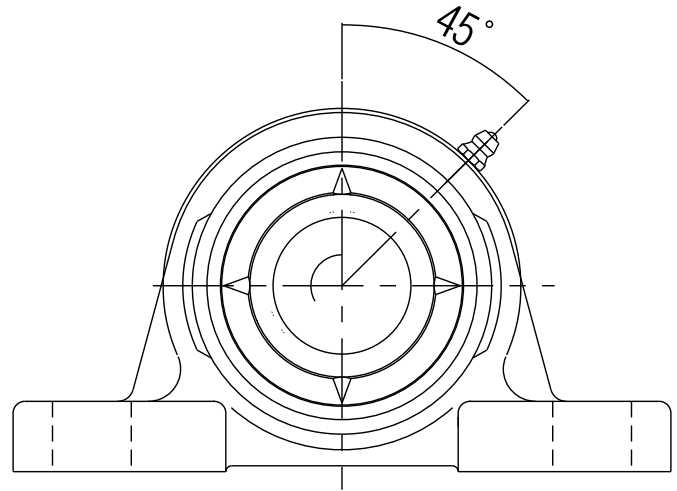

QUASI-STANDARD GREASE FITTINGS

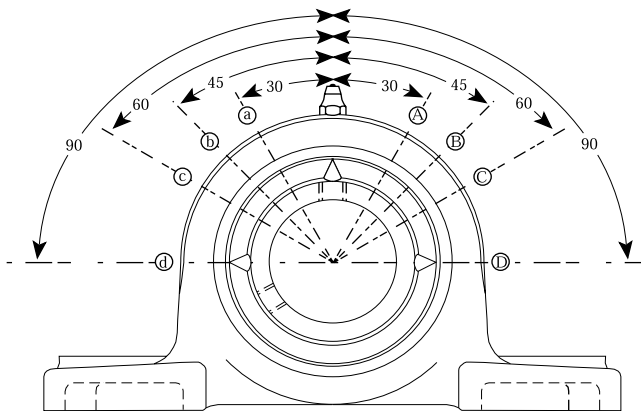

LOCATION OF GREASE FITTING

Position	Direction	Rotation	Suffix
Ⓐ	*Clockwise	30°	(10)
Ⓑ	Clockwise	45°	(11)
Ⓒ	Clockwise	60°	(12)
Ⓓ	Clockwise	90°	(13)
ⓐ	**Counterclockwise	30°	(14)
ⓑ	Counterclockwise	45°	(15)
ⓒ	Counterclockwise	60°	(16)
ⓓ	Counterclockwise	90°	(17)

*,** Facing NTN Brand Marking on the housing.

Example: UCP205D1 (11) grease fitting on the location capital "B."



BEARING RATINGS

The following load rating information applies to radial, angular contact and tapered roller bearings, but not specifically to thrust bearings. When determining load ratings, remember that all ratings are not absolute.

STATIC LOAD RATING

The static load rating is the Radial load that will cause a certain amount of immediate damage to the internal operating surfaces of the bearing. This level of surface damage is acceptable in most cases but in some demanding situations may cause too much noise, so a much lower load limitation may be necessary. A higher load may be feasible if subsequent noise is not intolerable.

Actual noise levels are very dependent upon speed so if the speed is low, more surface damage can be accepted. Also, tolerable noise levels vary depending upon the application.

The static load rating has nothing to do with allowable Axial or Thrust loading. In most cases, axial ratings are much lower than those in this catalog so please consult NTN when such loads approach 25% of this rating.

DYNAMIC LOAD RATING

The dynamic load rating has no direct significance other than that it is a number which, along with speed, must be used in an equation to calculate theoretical bearing life. Load usage of this magnitude is usually very inappropriate. Life will be too short and the bearing may become noisy if the static load rating is exceeded. The rating can be used to compare different bearings if the life equations that apply to them are the same.

LIMITING SPEEDS

Limiting speeds are shown for oil and grease and contact seals when appropriate. However, many factors are omitted in this simplified rating that can affect the actual limit in a given case. Although many applications can run at much higher speeds, it is prudent to take precautions and consult NTN when speeds exceed 75% of the limit.



**TECHNICAL
INFORMATION
BEARING
RATINGS & FITTING PRACTICE**

FITTING PRACTICE

The following five tables list the most likely suggestions for shaft and housing bore diameters for the more popular bearing series. The values in the tables provide the allowable deviations from the nominal diameters for most normal conditions.

UNUSUAL CONDITIONS

Different fits may be required for unusual conditions of loading, speed, temperature, housing or shaft material, wall thickness, vibration, poor surface finish and so on. For example, tighter fits are required for heavy loads, vibration, hollow shafts or thin housings, light alloy or plastic housings, etc. Consult NTN when in doubt.

ROTATING LOADS

The tables assume that the direction of load is constant. Where load rotates, reverse the rotating and stationary fits.

EFFECT ON CLEARANCES

The fits shown will usually work well with standard or C3 clearance bearings. Minor fit differences of .0001" or .0002" can usually be ignored but greater differences may require the use of other clearance classes.

AN EXAMPLE to illustrate the use of the tables:

A 6218 ball bearing has a **nominal** 90mm bore and a **nominal** inch bore of 3.5433". Assuming normal conditions, its shaft size is found in table 1. The 5th column, shows +7 to +1. These deviations applied to the **nominal** 3.5433" give a shaft size range of 3.5440" to 3.5434".



**TECHNICAL
INFORMATION
BEARING
RATINGS & FITTING PRACTICE**

STANDARD SHAFT SIZES
Deviation from Nominal Sizes in Units of 0.0001 inch

TABLE 1 – METRIC RADIAL BEARINGS													
Nominal Bearing Bore				Radial Loads									
				Pure Axial Loads		Stationary Shaft		Rotating Shaft					
mm		inch						max		min		Ball Bearings	
				over	incl	over	incl					max	min
3	6	0.1181	0.2362	+2	-1	-2	-5	+1	-1				
6	10	0.2362	0.3937	+3	-1	-2	-6	+2	-1				
10	18	0.3937	0.7087	+3	-1	-2	-7	+2	-1	+4	0		
18	30	0.7087	1.1811	+4	-2	-3	-8	+4	+1	+4	+1		
30	40	1.1811	1.5748	+4	-2	-4	-10	+5	+1	+5	+1	+5	+1
40	50	1.5748	1.9685	+4	-2	-4	-10	+5	+1	+8	+4	+8	+4
50	65	1.9685	2.5591	+5	-3	-4	-11	+6	+1	+9	+4	+9	+4
65	80	2.5591	3.1496	+5	-3	-4	-11	+6	+1	+9	+4	+12	+4
80	100	3.1496	3.9370	+5	-4	-5	-13	+7	+1	+11	+5	+14	+5
100	120	3.9370	4.7244	+5	-4	-5	-13	+7	+1	+14	+5	+18	+9
120	140	4.7244	5.5118	+6	-4	-6	-15	+8	+1	+16	+6	+20	+11
140	180	5.5118	7.0866	+6	-4	-6	-15	+8	+1	+20	+11	+27	+17
180	250	7.0866	9.8425	+6	-5	-6	-17	+9	+2	+24	+12	+31	+20
250	280	9.8425	11.0236	+6	-6	-7	-19	+11	+2	+26	+13	+35	+22
280	315	11.0236	12.4016	+6	-6	-7	-19	+11	+2	+26	+13	+51	+39

TABLE 2 – TAPERED ROLLER BEARINGS (INCH SERIES)						
Nominal Bearing Bore		Rotating Shaft		Stationary Shaft		
over	incl	max	min	max	min	
0	3	+15	+10	0	-5	
3	12	+25	+15	0	-10	
12	24	+50	+30	0	-20	

"J" prefix tapers are metric - see above.

TABLE 3 – INSERT BEARINGS SET SCREW & LOCKING COLLAR TYPES							
Nominal Bearing Bore (Inches)		Low Speed		Medium Speed		High Speed	
over	incl	max	min	max	min	max	min
0	.7	0	-10	0	-7	+7	+3
.7	1.2	0	-13	0	-8	+7	+3
1.2	2.0	0	-15	0	-10	+10	+4
2.0	3.2	0	-18	0	-12	+12	+4
3.2	4.8	0	-21	0	-14	+14	+5
Speed = Bore x RPM		2500 max		3500 max		7000 max	



**TECHNICAL
INFORMATION
BEARING
RATINGS & FITTING PRACTICE**

STANDARD HOUSING BORE SIZES
Deviation from Nominal Sizes in Units of 0.0001 inch

TABLE 4 – METRIC RADIAL BEARINGS											
Nominal Bearing O.D.				Stationary Housing				Rotating Housing			
mm		Inch		Normal		Heated Shaft		Normal		Thin Wall Housing	
over	incl	over	incl	max	min	max	min	max	min	max	min
10	18	0.3937	0.7087	+7	0	+10	+3	-2	-9	-4	-11
18	30	0.7087	1.1811	+8	0	+11	+3	-3	-11	-5	-13
30	50	1.1811	1.9685	+10	0	+14	+4	-3	-13	-6	-16
50	80	1.9685	3.1496	+12	0	+16	+4	-3	-15	-9	-21
80	120	3.1496	4.7244	+14	0	+19	+5	-4	-18	-11	-25
120	180	4.7244	7.0866	+16	0	+22	+6	-6	-22	-12	-28
180	250	7.0866	9.8425	+18	0	+24	+6	-8	-26	-14	-32
250	315	9.8425	12.4016	+20	0	+27	+7	-8	-28	-14	-34
315	400	12.4016	15.7480	+22	0	+29	+7	-8	-30	-17	-39
400	500	15.7480	19.6850	+25	0	+33	+8	-9	-34	-19	-44

TABLE 5 – TAPERED ROLLER BEARINGS (INCH SERIES)					
Nominal Cup O.D. Inch		Stationary Housing		Rotating Housing	
over	incl	max	min	max	min
0	3	+10	0	-5	-15
3	5	+10	0	-10	-20
5	12	+20	0	-10	-20
12	24	+30	+10	-10	-20

"J" prefix tapers are metric - see above.

NTN Bearings

Tolerance Tables, Clearance Tables and Interchange Data



TOLERANCES

Definitions pertaining to tolerance limits for boundary dimensions, various runouts, and internal clearance are given in AFBMA Standard 4, ANSI B3.4: Tolerance Definitions and Gaging Practice. The tolerance limits listed in this Standard refer exclusively to these concepts.

SYMBOLS COMMON TO RADIAL BEARINGS AND THRUST BEARINGS

d	=	Basic bore diameter
D	=	Basic outside diameter
V_{dp}	=	Single radial plane bore diameter variation
V_{Dp}	=	Single radial plane outside diameter variation
$r_{a\ max}$	=	Largest shaft and housing fillets which the bearing chamfer must clear
r_s	=	Single chamfer dimension of a ring
$r_{s\ min}$	=	Low limit of r
$r_{s\ max}$	=	High limit of r

SYMBOLS APPLICABLE TO RADIAL BEARINGS

B	=	Basic width of an individual inner ring; also of an individual outer ring when both rings have the same basic width
B_s	=	Single width of an inner ring; also that of an outer ring when both rings have the same basic width
V_{dmp}	=	Mean single plane bore diameter variation
V_{Dmp}	=	Single plane mean outside diameter deviations
K_1	=	Radial runout of an inner ring raceway
K_e	=	Radial runout of an outer ring raceway
S_d	=	Reference side runout with bore of an inner ring
S_D	=	Outside cylindrical surface runout with reference side of an outer ring
S_{ia}	=	Assembled bearing inner ring (or cone back face) runout with raceway
S_{ea}	=	Assembled bearing outer ring (or cup back face) runout with raceway
V_{Bs}	=	Width variation of an inner ring; also that of an outer ring when both rings have the same basic width

SYMBOLS APPLICABLE TO SINGLE DIRECTION THRUST BEARINGS

H	=	Basic bearing height
H_m	=	Actual bearing height
A_i	=	Raceway runout with flat seat face of shaft washer
A_e	=	Raceway runout with flat seat face of housing washer

TOLERANCE CLASS ABEC-1, RBEC-1

Tolerance limits for:

Metric ball and roller bearings (except tapered roller bearings) conforming to basic boundary plans.



Table 1 (Tolerance Limits in 0.0001 inch)

INNER RING														
BASIC BORE DIAMETER d				BORE Allowable Deviations		SINGLE RADIAL PLANE BORE DIAMETER VARIATION V _{dp}		SINGLE PLANE MEAN BORE DIAMETER DEVIATIONS V _{dmp}		RADIAL RUNOUT K _{ra} Max.	WIDTH Allowable Deviations from B			
mm		inch		Low	High	Diameter Series		Max.	Max.		Normal Single Bearings B _s		Modified Single Bearings B _s	
Over	Incl.	Over	Incl.			0.1	2,3,4			High	Low	High	Low	High
2.5	10	.0984	.3937	-3	+0	3	2.5	2.5	3	+0	-50	+0	-100	
10	18	.3937	.7087	-3	+0	3	2.5	2.5	4	+0	-50	+0	-100	
18	30	.7087	1.1811	-4	+0	3	2.5	2.5	5	+0	-50	+0	-100	
30	50	1.1811	1.9685	-5	+0	4	3	3	6	+0	-50	+0	-100	
50	80	1.9685	3.1496	-6	+0	4.5	3.5	3.5	8	+0	-60	+0	-150	
80	120	3.1496	4.7244	-8	+0	7.5	4.5	4.5	10	+0	-80	+0	-150	
120	180	4.7244	7.0866	-10	+0	10	6	6	12	+0	-100	+0	-200	
180	250	7.0866	9.8425	-12	+0	12	7.5	7.5	16	+0	-120	+0	-200	
250	315	9.8425	12.4015	-14	+0	15	9	9	20	+0	-140	+0	-200	
315	400	12.4015	15.7480	-16	+0	17	10	10	24	+0	-160	+0	-250	
400	500	15.7480	19.6850	-18	+0	20	12	12	26	+0	-180	—	—	
500	630	19.6850	24.8031	-20	+0	22	13	13	28	+0	-200	—	—	
630	800	24.8031	31.4961	-30	+0	25	15	15	32	+0	-300	—	—	
800	1000	31.4961	39.3701	-40	+0	—	—	—	35	+0	-400	—	—	
1000	1250	39.3701	49.2126	-50	+0	—	—	—	—	+0	-500	—	—	
1250	1600	49.2126	62.9921	-60	+0	—	—	—	—	+0	-600	—	—	
1600	2000	62.9921	78.7402	-80	+0	—	—	—	—	+0	-800	—	—	

OUTER RING												
BASIC OUTSIDE DIAMETER D				SINGLE RADIAL PLANE OUTSIDE DIAMETER VARIATION V _{Dp}					SINGLE PLANE MEAN OUTSIDE DIAMETER VARIATION V _{Dmp}	RADIAL RUNOUT K _{ra} Max.	WIDTH LIMITS	
mm		inch		All Bearings		Open Bearings		Bearings with Shields or Seals	Max.	K _{ra} Max.		
Over	Incl.	Over	Incl.	High	Low	0.1	2,3,4	2,3,4				
6	18	.2362	.7087	+0	-3	3	2.5	4	2.5	6	Identical to those of inner ring of the same bearing	
18	30	.7087	1.1811	+0	-4	3.5	3	4.5	3	6		
30	50	1.1811	1.9685	+0	-5	4.5	3	6.5	3	8		
50	80	1.9685	3.1496	+0	-5	5	4	8	4	10		
80	120	3.1496	4.7244	+0	-6	7.5	4.5	10	4.5	14		
120	150	4.7244	5.9055	+0	-8	9	5.5	12	5.5	16		
150	180	5.9055	7.0866	+0	-10	12	7.5	15	7.5	18		
180	250	7.0866	9.8425	+0	-12	15	9	—	9	20		
250	315	9.8425	12.4015	+0	-14	17	10	—	10	24		
315	400	12.4015	15.7480	+0	-16	20	12	—	12	28		
400	500	15.7480	19.6850	+0	-18	22	13	—	13	32		
500	630	19.6850	24.8031	+0	-20	25	15	—	15	40		
630	800	24.8031	31.4961	+0	-30	37	22	—	22	47		
800	1000	31.4961	39.3701	+0	-40	49	30	—	30	55		
1000	1250	39.3701	49.2126	+0	-50	—	—	—	—	64		
1250	1600	49.2126	62.9921	+0	-65	—	—	—	—	76		
1600	2000	62.9921	78.7402	+0	-80	—	—	—	—	90		
2000	2500	78.7402	98.4252	+0	-100	—	—	—	—	—		

Bore tolerance limits do not apply to tapered bore inner rings.

This refers to a ball bearing on which one or both sides are modified so two or more bearings can be mounted side by side as a unit.

Applies before mounting and after removal of internal or external snap ring.

No values have been established for diameter series 0 and 1.



TOLERANCE CLASS ABEC-5, RBEC-5

Tolerance limits for:

Metric ball and roller bearings (except instrument bearings and tapered roller bearings) conforming to basic boundary plans.

Table 2 (Tolerance Limits in 0.0001 inch)

INNER RING																
BASIC BORE DIAMETER <i>d</i>				BORE Allowable Deviations from <i>d</i>		SINGLE RADIAL PLANE BORE DIAMETER VARIATION V_{dp}		SINGLE PLANE MEAN BORE DIAMETER DEVIATIONS V_{dmp}	RUNOUT			WIDTH				
				All Bearings		Bearings of Diameter Series			Radial	Reference Side With Bore	Raceway With Reference Side	Allowable Deviations from <i>B</i>		Variation of B_s in Individual Ring V_{Bs}		
				d_{mp}		4,3,2,1,0	9,8					Normal Single Bearings	Modified Single Bearings			
Over	Incl.	Over	Incl.	Low	High	Max	Max	K_{ia} Max.	S_d Max.	S_{ia} Max.	High	Low	High	Low	Max.	
.6	10	.0236	.3937	-2	+0	2	1.5	1	1.5	3	3	+0	-16	+0	-100	2
10	18	.3937	.7087	-2	+0	2	1.5	1	1.5	3	3	+0	-32	+0	-100	2
18	30	.7087	1.1811	-2	+0	2.5	2	1	1.5	3	3	+0	-50	+0	-100	2
30	50	1.1811	1.9685	-2	+0	3	2.5	1.5	2.0	3	3	+0	-50	+0	-100	2
50	80	1.9685	3.1496	-3	+0	3.5	3	2	2.0	3	3	+0	-60	+0	-100	2
80	120	3.1496	4.7244	-3	+0	4	3	2	2.5	3	4	+0	-80	+0	-150	3
120	180	4.7244	7.0866	-4	+0	5	4	3	3.0	4	4	+0	-100	+0	-150	3
180	250	7.0866	9.8425	-5	+0	6	4.5	3	4.0	4	5	+0	-120	+0	-200	4
250	315	9.8425	12.4015	-5	+0	7	5.5	3.5	5.0	5	6	+0	-140	+0	-200	5
315	400	12.4015	15.7480	-6	+0	9	7	4.5	5.0	5	7	+0	-160	+0	-250	5

OUTER RING														
BASIC OUTSIDE DIAMETER <i>D</i>				SINGLE RADIAL PLANE OUTSIDE DIAMETER VARIATION V_{dp}					RUNOUT			WIDTH		
				All Bearings		Open Bearings		Bearings with Shields or Seals of Diameter Series	Radial	Cylindrical Surface with Reference Side	Raceway with Reference Side	Limits		Variation of B_s in Individual Ring V_{Bs}
						Bearings of Diameter Series						7,8,9	0,1,2,3,4	
Over	Incl.	Over	Incl.	High	Low	Max	Max	K_{ea} Max.	S_D Max.	S_{ea} Max.			Max.	
2.5	6	.0984	.2362	+0	-2	2	1.5	1	2	3	3	Identical	2	
6	18	.2362	.7087	+0	-2	2	1.5	1	2	3	3		2	
18	30	.7087	1.1811	+0	-2	2.5	2	1	2	3	3	to those	2	
30	50	1.1811	1.9685	+0	-2	3	2	1.5	2	3	3		2	
50	80	1.9685	3.1496	+0	-3	3.5	3	2	3	3	4	of inner	2	
80	120	3.1496	4.7244	+0	-3	4	3	2	4	3	5		3	
120	150	4.7244	5.9055	+0	-4	4.5	3	2.5	4	4	5	ring of	3	
150	180	5.9055	7.0866	+0	-5	5	4	3	5	4	6		3	
180	250	7.0866	9.8425	+0	-5	6	4.5	3	5	4	6		4	
250	315	9.8425	12.4015	+0	-5	7	5.5	3.5	6	5	7	the same	5	
315	400	12.4015	15.7480	+0	-6	8	6	4	7	5	8		5	
400	500	15.7480	19.6850	+0	-7	9	6.5	4.5	8	6	9	bearing	6	
500	630	19.6850	24.8031	+0	-8	11	8.5	5.5	9	6	10		6	

For Instrument Ball Bearing tolerances see AFBMA Standard 12, ANSI B3.10.

Bore tolerance limits do not apply to tapered bore inner rings.

Does not apply to roller bearings or self-aligning ball bearings.

This refers to a ball bearing on which one or both sides are modified so two or more bearings can be mounted side by side as a unit.

For bearings with shields or seals of diameter series 9 and 8, D_s is not restricted.

Applies to bearings of width series 1 or narrower.

No values have been established for capped bearings.

TOLERANCE CLASS ABEC-7

Tolerance limits for:

Metric radial and angular contact ball bearings (except instrument bearings).



Table 3 (Tolerance Limits in 0.0001 inch)

INNER RING																	
BASIC BORE DIAMETER <i>d</i>				SINGLE PLANE MEAN OUTER DIAMETER DEVIATION Basic Bearings <i>d_{mp}</i>		SINGLE RADIAL PLANE BORE DIAMETER VARIATION <i>V_{dp}</i>		SINGLE PLANE MEAN BORE DIAMETER DEVIATIONS <i>V_{dmp}</i>		RUNOUT			WIDTH				
						Bearings of Diameter Series				Radial	Reference Side With Bore	Raceway With Reference Side	Allowable Deviations from B		Variation of <i>B_s</i> in Individual Ring		
mm	inch	mm	inch	Low	High	7,8,9	0,1,2,3,4	Max	<i>K_{ra}</i> Max.	<i>S_d</i> Max.	<i>S_{ra}</i> Max.	High	Low	High	Low	High	Low
.6	10	.0236	.3937	-1.5	+0	1.5	1	1	1.0	1.0	1.0	+0	-16	+0	-100	1.0	
10	18	.3937	.7087	-1.5	+0	1.5	1	1	1.0	1.0	1.0	+0	-32	+0	-100	1.0	
18	30	.7087	1.1811	-1.5	+0	2	1.5	1	1.0	1.5	1.5	+0	-50	+0	-100	1.0	
30	50	1.1811	1.9685	-2.0	+0	2.5	2	1	1.5	1.5	1.5	+0	-50	+0	-100	1.0	
50	80	1.9685	3.1496	-2.0	+0	3	2	1.5	1.5	2.0	1.5	+0	-60	+0	-100	1.5	
80	120	3.1496	4.7244	-2.5	+0	3	2.5	1.5	2.0	2.0	2.0	+0	-80	+0	-150	1.5	
120	180	4.7244	7.0866	-3.0	+0	4	3	2	3.0	3.0	3.0	+0	-100	+0	-150	2.0	
180	250	7.0866	9.8425	-4.0	+0	4.5	3.5	2.5	3.0	3.0	3.0	+0	-120	+0	-200	2.0	
250	315	9.8425	12.4015	-5.0	+0	—	—	—	4.0	4.0	4.0	+0	-140	+0	-200	3.0	

OUTER RING													
BASIC OUTSIDE DIAMETER <i>D</i>				SINGLE RADIAL PLANE OUTSIDE DIAMETER VARIATION <i>V_{dp}</i>					RUNOUT			WIDTH	
				All Bearings	Open Bearings		Bearings with Shields or Seals		Radial	Cylindrical Surface with Reference Side	Raceway with Reference Side	Limits	Variation of <i>B_s</i> in Individual Ring
Bearings of Diameter Series		Diameter Series											
mm	inch	mm	inch	High	Low	7,8,9	0,1,2,3,4	4,3,2,1,0	<i>K_{ca}</i> Max.	<i>S_D</i> Max.	<i>S_{ca}</i> Max.		
2.5	6	.0984	.2362	+0	-2	1.5	1	1	2		1	Identical	1
6	18	.2362	.7087	+0	-2	1.5	1	1	1.5	1.5	2	to those	1
18	30	.7087	1.1811	+0	-2	2	1.5	1	1.5	1.5	2	of inner	1
30	50	1.1811	1.9685	+0	-2	2.5	2	1	2.0	1.5	2	ring of	2
50	80	1.9685	3.1496	+0	-2	3	2	1.5	2.0	1.5	2	the same	3
80	120	3.1496	4.7244	+0	-3	3	2.5	1.5	2.0	2.0	2	bearing	3
120	150	4.7244	5.9055	+0	-4	3.5	3	2	3.0	2.0	3		2
150	180	5.9055	7.0866	+0	-4	4	3	2	3.0	2.0	3		2
180	250	7.0866	9.8425	+0	-4	4.5	3	2.5	4.0	3.0	4		3
250	315	9.8425	12.4015	+0	-5	5	4	3	4.0	3.0	4		3
315	400	12.4015	15.7480	+0	-5	6	4.5	3	5.0	4.0	5		3
400	500	15.7480	19.6850	+0	-6	—	—	—	5.0	4.0	5		4

For Instrument Ball Bearing tolerances see AFBMA Standard 12, ANSI B3.10.

Does not apply to self-aligning ball bearings.

This refers to a ball bearing on which one or both sides are modified so two or more bearings can be mounted side by side as a unit.

For bearings with shields or seals of diameter series 9 and 8, *D_s* is not restricted.

Applies to bearings of width series 1 or narrower.

No values have been established for capped bearings.



TOLERANCE CLASS ABEC-9

Tolerance limits for:

Metric radial and angular contact ball bearings (except instrument bearings).

Table 4 (Tolerance Limits in 0.0001 inch)

INNER RING														
BASIC BORE DIAMETER <i>d</i>				SINGLE RADIAL PLANE BORE DIAMETER VARIATION <i>V_{dp}</i>	SINGLE PLANE MEAN BORE DIAMETER DEVIATIONS <i>V_{dmp}</i>	RUNOUT			WIDTH					
mm		inch				Radial	Reference Side With Bore	Raceway With Reference Side	Allowable Deviations from B		Variation of <i>B_s</i> in Individual Ring <i>V_{Bs}</i>			
<i>Over</i>	<i>Incl.</i>	<i>Over</i>	<i>Incl.</i>			<i>K_{ia}</i> Max.	<i>S_d</i> Max.	<i>S_{ia}</i> Max.	Normal Single Bearings <i>B_s</i>	Modified Single Bearings <i>B_s</i>				
				Max	Max		High	Low	High	Low				
.6	10	.0236	.3937	1	.5	.5	.5	.5	+ 0	- 10	+ 0	- 100	.5	
10	18	.3937	.7087	1	.5	.5	.5	.5	+ 0	- 32	+ 0	- 100	.5	
18	30	.7087	1.1811	1	.5	1.0	.5	1.0	+ 0	- 50	+ 0	- 100	.5	
30	50	1.1811	1.9685	1	.5	1.0	.5	1.0	+ 0	- 50	+ 0	- 100	.5	
50	80	1.9685	3.1496	1.5	1	1.0	.5	1.0	+ 0	- 60	+ 0	- 100	.5	
80	120	3.1496	4.7244	2	1	1.0	1.0	1.0	+ 0	- 80	+ 0	- 150	1.0	
120	150	4.7244	5.9055	3	1.5	1.0	1.0	1.0	+ 0	- 100	+ 0	- 150	1.0	
150	180	5.9055	7.0866	3	1.5	2.0	1.5	2.0	+ 0	- 120	+ 0	- 200	1.5	
180	250	7.0866	9.8425	3	1.5	2.0	1.5	2.0	+ 0	- 140	+ 0	- 200	1.5	

OUTER RING														
BASIC OUTSIDE DIAMETER <i>D</i>				SINGLE RADIAL PLANE OUTSIDE DIAMETER VARIATION		RUNOUT			WIDTH					
mm		inch		<i>V_{Dp}</i>	<i>V_{dmp}</i>	Radial	Outside Cylindrical Surface with Reference Side	Raceway with Reference Side	Limits	Variation of <i>B_s</i> in Individual Ring <i>V_{Bs}</i>				
<i>Over</i>	<i>Incl.</i>	<i>Over</i>	<i>Incl.</i>			Max	<i>K_{ea}</i> Max.	<i>S_D</i> Max.			<i>S_{ea}</i> Max.			
2.5	18	.0984	.7087	1	.5	.5	.5	.5	Identical to	.5				
18	30	.7087	1.1811	1.5	1	1.0	.5	1.0		.5				
30	50	1.1811	1.9685	1.5	1	1.0	.5	1.0		.5				
50	80	1.9685	3.1496	1.5	1	1.5	.5	1.5	those of	.5				
80	120	3.1496	4.7244	2	1	2.0	1.0	2.0		1.0				
120	150	4.7244	5.9055	2	1	2.0	1.0	2.0	inner ring	1.0				
150	180	5.9055	7.0866	3	1.5	2.0	1.0	2.0		1.0				
180	250	7.0866	9.8425	3	1.5	2.5	1.5	2.5	of the same	1.5				
250	315	9.8425	12.4015	3	1.5	2.5	1.5	2.5		1.5				
315	400	12.4015	15.7480	4	2	3.0	2.5	3.0		bearing	2.5			

Applies to bearings of metric width series 1 or narrower.

Does not apply to self-aligning ball bearings.

This refers to a ball bearing on which one or both sides are modified so two or more bearings can be mounted side by side as a unit.

These limits apply before seals or shields are inserted.

For Instrument Ball Bearing tolerances see AFBMA Standard 12, ANSI B3.10.

No values have been established for capped bearings.

Tolerance Limits for Dimensions and Runout.

There is only one class of tolerances established for thrust ball bearings.

They conform with those adopted by ISO (ISO Recommendation R199).

Tolerance Limits for:

Metric single direction thrust ball bearings (of dimensions conforming to the basic plan for boundary dimensions of single direction, metric thrust bearings).



Table 5 (Tolerance Limits in 0.0001 inch)

THRUST BALL BEARINGS															
BASIC BORE DIAMETER <i>d</i>				SHAFT WASHER Allowable Deviations from <i>d</i>		BOTH INDIVIDUAL WASHERS Raceway Runout with Flat Seat Face <i>A₁, A_e</i>	BEARING HEIGHT Allowable Deviations from H		BASIC OUTSIDE DIAMETER <i>D</i>				HOUSING WASHER Allowable Deviations from <i>D</i>		
mm		inch		<i>d_s</i>		Max.	<i>H_m</i>		mm		inch		<i>D_s</i>		
Over	Incl.	Over	Incl.	Low	High		High	Low	Over	Incl.	Over	Incl.	High	Low	
0	18	.0000	.7087	-3	+2	4	+0	-30	10	18	.3937	.7087	+0	-4	
18	30	.7087	1.1811	-4	+3	4	+0	-30	18	30	.7087	1.1811	+0	-5	
30	50	1.1811	1.9685	-5	+4	4	+0	-39	30	50	1.1811	1.9685	+0	-6	
50	80	1.9685	3.1496	-6	+5	4	+0	-49	50	80	1.9685	3.1496	+0	-7	
80	120	3.1496	4.7244	-8	+6	6	+0	-59	80	120	3.1496	4.7244	+0	-9	
120	180	4.7244	7.0866	-10	+7	6	+0	-69	120	180	4.7244	7.0866	+0	-10	
180	250	7.0866	9.8425	-12	+9	8	+0	-79	180	250	7.0866	9.8425	+0	-12	
250	315	9.8425	12.4015	-14	+10	10	+0	-89	250	315	9.8425	12.4015	+0	-14	
315	400	12.4015	15.7480	-16	+11	12	+0	-118	315	400	12.4015	15.7480	+0	-16	
400	500	15.7480	19.6850	-18	+13	12	—	—	400	500	15.7480	19.6850	+0	-18	
500	630	19.6850	24.8031	-20	+14	14	—	—	500	630	19.6850	24.8031	+0	-20	
630	800	24.8031	31.4961	-30	+15	16	—	—	630	800	24.8031	31.4961	+0	-30	
800	1000	31.4961	39.3701	-40	+17	18	—	—	800	1000	31.4961	39.3701	+0	-40	
1000	1250	39.3701	49.2126	-49	+19	20	—	—	1000	1250	39.3701	49.2126	+0	-49	
									1250	1600	49.2126	62.9921	+0	-59	



Tolerance Limits for:
Metric series tapered roller bearings.

Table 6 (Tolerance Limits in 0.001 mm)

INNER RING																									
Bore Diameter d nominal mm		Bore Diameter												Width B Deviations (Inner Ring)				Bearing Width T Deviations (Overall)				Radial Run-Out R_i Maximum			
		dm Deviations						d Deviations						Class 0,6,5		Class 4		Class 0		Class 6,5,4		Class			
		Class 0 KB		Class 6,5		Class 4		Class 0 KB		Class 6,5		Class 4		High	Low	High	Low	High	Low	High	Low	High	Low	0	6
Over	Incl.	High	Low	High	Low	High	Low	Max.	Min.	Max.	Min.	Max.	Min.	High	Low	High	Low	High	Low	High	Low	High	Low	High	Low
10	18	0	-8	0	-7	0	-5	+3	-11	+1	-8	0	-5	0	-200	0	-200	+200	-200	+200	0	15	7	3.5	2.5
18	30	0	-10	0	-8	0	-6	+3	-13	+1	-9	0	-6	0	-200	0	-200	+200	-200	+200	0	18	8	4	3
30	50	0	-12	0	-10	0	-8	+3	-15	+1	-11	0	-8	0	-240	0	-240	+200	-200	+200	0	20	10	5	4
50	80	0	-15	0	-12	0	-9	+4	-19	+2	-14	0	-9	0	-300	0	-300	+200	-200	+200	0	25	10	5	4
80	120	0	-20	0	-15	0	-10	+5	-25	+3	-18	0	-10	0	-400	0	-400	+300	-300	+200	-200	30	13	6	5
120	180	0	-25	0	-18	0	-13	+6	-31	+3	-21	0	-13	0	-500	0	-500	+400	-400	+350	-250	35	18	8	6
180	250	0	-30	0	-22	0	-15	+8	-38	+4	-26	0	-15	0	-600	0	-600	+500	-500	+350	-250	50	20	10	8
250	315	0	-35	—	—	—	—	+9	-44	—	—	—	—	0	-700	—	—	+600	-600	—	—	60	—	—	—
315	400	0	-40	—	—	—	—	+10	-50	—	—	—	—	0	-800	—	—	+700	-700	—	—	70	—	—	—

Table 6-A (Tolerance Limits in 0.0001 inch)

INNER RING																									
Bore Diameter d nominal inch		Bore Diameter												Width B Deviations (Inner Ring)				Bearing Width T Deviations (Overall)				Radial Run-Out R_i Maximum			
		dm Deviations						d Deviations						Class 0,6,5		Class 4		Class 0		Class 6,5,4		Class			
		Class 0 KB		Class 6,5		Class 4		Class 0 KB		Class 6,5		Class 4		High	Low	High	Low	High	Low	High	Low	High	Low	0	6
Over	Incl.	High	Low	High	Low	High	Low	Max.	Min.	Max.	Min.	Max.	Min.	High	Low	High	Low	High	Low	High	Low	High	Low	High	Low
.3937	.7087	0	-3.1	0	-2.8	0	-2.0	+1.2	-4.3	+.4	-3.1	0	-2.0	0	-78.7	0	-78.7	+78.7	-78.7	+78.7	0	5.9	2.8	1.4	1.0
.7087	1.1811	0	-3.9	0	-3.1	0	-2.4	+1.2	-5.1	+.4	-3.5	0	-2.4	0	-78.7	0	-78.7	+78.7	-78.7	+78.7	0	7.1	3.1	1.6	1.2
1.1811	1.9685	0	-4.7	0	-3.9	0	-3.1	+1.2	-5.9	+.4	-4.3	0	-3.1	0	-94.5	0	-94.5	+78.7	-78.7	+78.7	0	7.9	3.9	2.0	1.6
1.9685	3.1496	0	-5.9	0	-4.7	0	-3.5	+1.6	-7.5	+.8	-5.5	0	-3.5	0	-118.1	0	-118.1	+78.7	-78.7	+78.7	0	9.8	3.9	2.0	1.6
3.1496	4.7244	0	-7.9	0	-5.9	0	-3.9	+2.0	-9.8	+1.2	-7.1	0	-3.9	0	-157.5	0	-157.5	+118.1	-118.1	+78.7	-78.7	11.8	5.1	2.4	2.0
4.7244	7.0866	0	-9.8	0	-7.1	0	-5.1	+2.4	-12.2	+1.2	-8.3	0	-5.1	0	-196.9	0	-196.9	+157.5	-157.5	+137.8	-98.4	13.8	7.1	3.1	2.4
7.0866	9.8425	0	-11.8	0	-8.7	0	-5.9	+3.1	-15.0	+1.6	-10.2	0	-5.9	0	-236.2	0	-236.2	+196.5	-196.5	+137.8	-98.4	19.7	7.9	3.9	3.1
9.8425	12.4016	0	-13.8	—	—	—	—	+3.5	-17.3	—	—	—	—	0	-275.6	—	—	+236.2	-236.2	—	—	23.6	—	—	—
12.4016	15.7480	0	-15.7	—	—	—	—	+3.9	-19.7	—	—	—	—	0	-315.0	—	—	+275.6	-275.6	—	—	27.6	—	—	—

dm is defined as the arithmetical mean of the largest and the smallest single diameter of the bore obtained by two-point measurements.

The values of deviation of d are valid for two-point measurements only.

Deviations of d for Class 0 apply only to diameter series 0, 2 and 3, and do not apply to either of the following cases: over 40 mm of d in diameter series 0, or over 180 mm of d in diameter series 2.

Deviations of d for Class 6 apply only to diameter series 0, 2 and 3, and do not apply to the case of over 60 mm of d in diameter series 0.

Deviations of d for Class 5 apply only to diameter series 0, 2 and 3.

KB is the symbol for limit deviations of dm and d for Class 0.

REMARKS:

The high deviations of bore diameter specified in this table do not apply within a distance of twice the nominal ring chamfer dimension from the ring face.

Table 7 (Tolerance Limits in 0.001 mm)

OUTER RING																	
Outside Diameter <i>D</i> Nominal mm		BEARING OUTSIDE DIAMETER												Radial Run-Out Re Max.			
		<i>D_m</i> Deviations						<i>D</i> Deviations									
		Class O hB		Class 6,5		Class 4		Class O hB		Class 6,5		Class 4		Class 0	Class 6	Class 5	Class 4
Over	Incl.	High	Low	High	Low	High	Low	Max.	Min.	Max.	Min.	Max.	Min.				
18	30	+0	-9	+0	-8	+0	-6	+2	-11	+1	-9	+0	-6	18	9	6	4
30	50	+0	-11	+0	-9	+0	-7	+3	-14	+2	-11	+0	-7	20	10	7	5
50	80	+0	-13	+0	-11	+0	-9	+4	-17	+2	-13	+0	-9	25	13	8	5
80	120	+0	-15	+0	-13	+0	-10	+5	-20	+2	-15	+0	-10	35	18	10	6
120	150	+0	-18	+0	-15	+0	-11	+6	-24	+3	-18	+0	-11	40	20	11	7
150	180	+0	-25	+0	-18	+0	-13	+7	-32	+3	-21	+0	-13	45	23	13	8
180	250	+0	-30	+0	-20	+0	-15	+8	-38	+4	-24	+0	-15	50	25	15	10
250	315	+0	-35	+0	-25	+0	-18	+9	-44	+4	-29	+0	-18	60	30	18	11
315	400	+0	-40	+0	-28	+0	-20	+10	-50	+5	-33	+0	-20	70	35	20	13
400	500	+0	-45	—	—	—	—	+12	-57	—	—	—	—	80	—	—	—
500	630	+0	-50	—	—	—	—	+14	-64	—	—	—	—	100	—	—	—

Table 7-A (Tolerance Limits in 0.0001 inch)

OUTER RING																	
Outside Diameter <i>D</i> Nominal inch		BEARING OUTSIDE DIAMETER												Radial Run-Out Re Max.			
		<i>D_m</i> Deviations						<i>D</i> Deviations									
		Class O hB		Class 6,5		Class 4		Class O hB		Class 6,5		Class 4		Class 0	Class 6	Class 5	Class 4
Over	Incl.	High	Low	High	Low	High	Low	Max.	Min.	Max.	Min.	Max.	Min.				
.7087	1.1811	+0	-3.5	+0	-3.1	+0	-2.4	+ .8	-4.3	+ .4	-3.5	+0	-2.4	7.1	3.5	2.4	1.6
1.1811	1.9685	+0	-4.3	+0	-3.5	+0	-2.8	+1.2	-5.5	+ .8	-4.3	+0	-2.8	7.9	3.9	2.8	2.0
1.9685	3.1496	+0	-5.1	+0	-4.3	+0	-3.5	+1.6	-6.7	+ .8	-5.1	+0	-3.5	9.8	5.1	3.1	2.0
3.1496	4.7244	+0	-5.9	+0	-5.1	+0	-3.9	+2.0	-7.9	+ .8	-5.9	+0	-3.9	13.8	7.1	3.9	2.4
4.7244	5.9055	+0	-7.1	+0	-5.9	+0	-4.3	+2.4	-9.4	+1.2	-7.1	+0	-4.3	15.7	7.9	4.3	2.8
5.9055	7.0866	+0	-9.8	+0	-7.1	+0	-5.1	+2.8	-12.6	+1.2	-8.3	+0	-5.1	17.7	9.1	5.1	3.1
7.0866	9.8425	+0	-11.8	+0	-7.9	+0	-5.9	+3.1	-15.0	+1.6	-9.4	+0	-5.9	19.7	9.8	5.9	3.9
9.8425	12.4016	+0	-13.8	+0	-9.8	+0	-7.1	+3.5	-17.3	+1.6	-11.4	+0	-7.1	23.6	11.8	7.1	4.3
12.4016	15.7480	+0	-15.7	+0	-11.0	+0	-7.9	+3.9	-19.7	+2.0	-13.0	+0	-7.9	27.6	13.8	7.9	5.1
15.7480	19.6850	+0	-17.7	—	—	—	—	+4.7	-22.4	—	—	—	—	31.5	—	—	—
19.6850	24.8031	+0	-19.7	—	—	—	—	+5.5	-25.2	—	—	—	—	39.4	—	—	—

D_m is defined as the arithmetical mean of the largest and the smallest single diameter of the outside surface obtained by two-point measurements.

hB is the symbol for limit deviations of *DM* and *D* for Class 0.

The values of deviation of *D* are valid for two-point measurements only.

Deviations of *D* for Class 0 apply only to diameter series 0, 2 and 3, and do not apply to either of the following cases: over 80 mm of *D* in diameter series 0, or over 315 mm of *D* in diameter series 2.

Deviations of *D* for Class 6 apply only to diameter series 0, 2 and 3, and do not apply to the case of over 95 mm of *D* in diameter series 0.

REMARKS:

The low deviations of outside diameter specified in this table do not apply within a distance of twice the nominal ring chamfer dimensions from the ring face.



Tolerance limits for:
Tapered roller bearings with "J" prefixed part numbers.

Table 8

Cone Bore				Class K				Class N				Class C				Class B			
inch		mm		.0001 inch		.001 mm		.0001 inch		.001 mm		.0001 inch		.001 mm		.0001 inch		.001 mm	
Over	Incl.	Over	Incl.	High	Low	High	Low	High	Low	High	Low	High	Low	High	Low	High	Low	High	Low
.3937	.7087	10	18	+0	-5	+0	-13	+0	-5	+0	-13	+0	-4	+0	-10	+0	-3	+0	-8
.7087	1.1811	18	30	+0	-5	+0	-13	+0	-5	+0	-13	+0	-4	+0	-10	+0	-3	+0	-8
1.1811	1.9685	30	50	+0	-5	+0	-13	+0	-5	+0	-13	+0	-4	+0	-10	+0	-4	+0	-10
1.9685	3.1496	50	80	+0	-6	+0	-15	+0	-6	+0	-15	+0	-5	+0	-13	+0	-4	+0	-10
3.1496	4.7244	80	120	+0	-8	+0	-20	+0	-8	+0	-20	+0	-5	+0	-13	+0	-4	+0	-10
4.7244	7.0866	120	180	+0	-10	+0	-25	+0	-10	+0	-25	+0	-5	+0	-13	+0	-4	+0	-10
7.0866	9.8425	180	250	+0	-12	+0	-30	+0	-12	+0	-30	+0	-6	+0	-15	+0	-5	+0	-13
9.8425	12.4016	250	315	+0	-14	+0	-35	+0	-14	+0	-35	+0	-7	+0	-18	+0	-5	+0	-13

Table 9

Cup O.D.				Class K				Class N				Class C				Class B			
inch		mm		.0001 inch		.001 mm		.0001 inch		.001 mm		.0001 inch		.001 mm		.0001 inch		.001 mm	
Over	Incl.	Over	Incl.	High	Low	High	Low	High	Low	High	Low	High	Low	High	Low	High	Low	High	Low
.7087	1.1811	18	30	+0	-8	+0	-20	+0	-8	+0	-20	+0	-3	+0	-8	+0	-3	+0	-8
1.1811	1.9685	30	50	+0	-8	+0	-20	+0	-8	+0	-20	+0	-4	+0	-10	+0	-2	+0	-8
1.9685	3.1496	50	80	+0	-8	+0	-20	+0	-8	+0	-20	+0	-4	+0	-10	+0	-3.5	+0	-9
3.1496	4.7244	80	120	+0	-8	+0	-20	+0	-8	+0	-20	+0	-5	+0	-13	+0	-4	+0	-10
4.7244	5.9055	120	150	+0	-10	+0	-25	+0	-10	+0	-25	+0	-5	+0	-13	+0	-4	+0	-10
5.9055	7.0866	150	180	+0	-10	+0	-25	+0	-10	+0	-25	+0	-5	+0	-13	+0	-4	+0	-10
7.0866	9.8425	180	250	+0	-12	+0	-30	+0	-12	+0	-30	+0	-6	+0	-15	+0	-5	+0	-13
9.8425	12.4016	250	315	+0	-16	+0	-40	+0	-16	+0	-40	+0	-8	+0	-20	+0	-6	+0	-15
12.4016	15.7480	315	400	+0	-16	+0	-40	+0	-16	+0	-40	+0	-8	+0	-20	-	-	-	-
15.7480	19.6850	400	500	+0	-20	+0	-50	+0	-20	+0	-50	+0	-10	+0	-25	-	-	-	-

Table 10

Cone Bore				Class K				Class N				Class C				Class B			
inch		mm		.0001 inch		.001 mm		.0001 inch		.001 mm		.0001 inch		.001 mm		.0001 inch		.001 mm	
Over	Incl.	Over	Incl.	High	Low	High	Low	High	Low	High	Low	High	Low	High	Low	High	Low	High	Low
.3937	.7087	10	18	+79	-0	+200	-0	+39	-0	+100	-0	+79	-79	+200	-200	+79	-79	+200	-200
.7087	1.1811	18	30	+79	-0	+200	-0	+39	-0	+100	-0	+79	-79	+200	-200	+79	-79	+200	-200
1.1811	1.9685	30	50	+79	-0	+200	-0	+39	-0	+100	-0	+79	-79	+200	-200	+79	-79	+200	-200
1.9685	3.1496	50	80	+79	-0	+200	-0	+39	-0	+100	-0	+79	-79	+200	-200	+79	-79	+200	-200
3.1496	4.7244	80	120	+79	-79	+200	-200	+39	-0	+100	-0	+79	-79	+200	-200	+79	-79	+200	-200
4.7244	7.0866	120	180	+79	-79	+200	-200	+59	-0	+150	-0	+79	-98	+200	-250	+79	-98	+200	-250
7.0866	9.8425	180	250	+79	-79	+200	-200	+59	-0	+150	-0	+79	-118	+200	-300	+79	-118	+200	-300
9.8425	12.4016	250	315	+79	-79	+200	-200	+79	-0	+200	-0	+79	-118	+200	-300	+79	-118	+200	-300

Table 11

CONE WIDTH TOLERANCES																			
Cone Bore				Class K				Class N				Class C				Class B			
inch		mm		.0001 inch		.001 mm		.0001 inch		.001 mm		.0001 inch		.001 mm		.0001 inch		.001 mm	
Over	Incl.	Over	Incl.	High	Low	High	Low	High	Low	High	Low	High	Low	High	Low	High	Low	High	Low
.3937	.7087	10	18	+0	-39	+0	-100	+0	-20	+0	-50	+0	-79	+0	-200	+0	-79	+0	-200
.7087	1.1811	18	30	+0	-39	+0	-100	+0	-20	+0	-50	+0	-79	+0	-200	+0	-79	+0	-200
1.1811	1.9685	30	50	+0	-39	+0	-100	+0	-20	+0	-50	+0	-79	+0	-200	+0	-79	+0	-200
1.9685	3.1496	50	80	+0	-59	+0	-150	+0	-20	+0	-50	+0	-118	+0	-300	+0	-118	+0	-300
3.1496	4.7244	80	120	+0	-59	+0	-150	+0	-20	+0	-50	+0	-118	+0	-300	+0	-118	+0	-300
4.7244	7.0866	120	180	+0	-79	+0	-200	+0	-20	+0	-50	+0	-118	+0	-300	+0	-118	+0	-300
7.0866	9.8425	180	250	+0	-79	+0	-200	+0	-20	+0	-50	+0	-138	+0	-350	+0	-138	+0	-350
9.8425	12.4016	250	315	+0	-79	+0	-200	+0	-20	+0	-50	+0	-138	+0	-350	+0	-138	+0	-350

Table 12

CUP WIDTH TOLERANCES																			
Cup O.D.				Class K				Class N				Class C				Class B			
inch		mm		.0001 inch		.001 mm		.0001 inch		.001 mm		.0001 inch		.001 mm		.0001 inch		.001 mm	
Over	Incl.	Over	Incl.	High	Low	High	Low	High	Low	High	Low	High	Low	High	Low	High	Low	High	Low
.7087	1.1811	18	30	+0	-59	+0	-150	+0	-39	+0	-100	+0	-59	+0	-150	+0	-59	+0	-150
1.1811	1.9685	30	50	+0	-59	+0	-150	+0	-39	+0	-100	+0	-59	+0	-150	+0	-59	+0	-150
1.9685	3.1496	50	80	+0	-59	+0	-150	+0	-39	+0	-100	+0	-59	+0	-150	+0	-59	+0	-150
3.1496	4.7244	80	120	+0	-79	+0	-200	+0	-39	+0	-100	+0	-79	+0	-200	+0	-79	+0	-200
4.7244	5.9055	120	150	+0	-79	+0	-200	+0	-39	+0	-100	+0	-79	+0	-200	+0	-79	+0	-200
5.9055	7.0866	150	180	+0	-79	+0	-200	+0	-39	+0	-100	+0	-98	+0	-250	+0	-98	+0	-250
7.0866	9.8425	180	250	+0	-98	+0	-250	+0	-39	+0	-100	+0	-98	+0	-250	+0	-98	+0	-250
9.8425	12.4016	250	315	+0	-98	+0	-250	+0	-39	+0	-100	+0	-118	+0	-300	+0	-118	+0	-300
12.4016	15.7480	315	400	+0	-98	+0	-250	+0	-39	+0	-100	+0	-118	+0	-300	-	-	-	-
15.7480	19.6850	400	500	+0	-118	+0	-300	+0	-39	+0	-100	+0	-138	+0	-350	-	-	-	-

Table 13

ASSEMBLED BEARING MAXIMUM RADIAL RUNOUT											
Cup O.D.				Class K		Class N		Class C		Class B	
Inch		mm		.0001 inch	.001 mm	.0001 inch	.001 mm	.0001 inch	.001 mm	.0001 inch	.001 mm
Over	Incl.	Over	Incl.								
.7087	1.1811	18	30	12	30	12	30	2	5	1	2.5
1.1811	1.9685	30	50	12	30	12	30	2.4	6	1	2.5
1.9685	3.1496	50	80	12	30	12	30	2.4	6	1.4	3.5
3.1496	4.7244	80	120	16	40	16	40	2.4	6	1.4	3.5
4.7244	5.9055	120	150	16	40	16	40	2.8	7	1.4	3.5
5.9055	7.0866	150	180	16	40	16	40	3	8	1.5	4
7.0866	9.8425	180	250	20	50	20	50	4	10	2	5
9.8425	12.4016	250	315	20	50	20	50	4.3	11	2	5
12.4016	15.7480	315	400	20	50	20	50	5	13	-	-
15.7480	19.6850	400	500	25	65	25	65	7	18	-	-



Tolerance limits for:
Inch series tapered roller bearings.

Table 14

Cone Bore				Class 4				Class 3				Class 0				Class 00			
inch		mm		.0001 inch		.001 mm		.0001 inch		.001 mm		.0001 inch		.001 mm		.0001 inch		.001 mm	
Over	Incl.	Over	Incl.	High	Low	High	Low	High	Low	High	Low	High	Low	High	Low	High	Low	High	Low
—	3	—	76.2	+5	-0	+13	-0	+5	-0	+13	-0	5	-0	+13	-0	+3	-0	+8	0
3	12	76.2	304.8	+10	-0	+25	-0	+5	-0	+13	-0	5	-0	+13	-0	+3	-0	+8	0
12	24	304.8	609.6	+20	-0	+51	-0	+10	-0	+25	-0	—	—	—	—	—	—	—	—
24	36	609.6	914.4	+30	-0	+76	-0	+15	-0	+38	-0	—	—	—	—	—	—	—	—
36	48	914.4	1219.2	+40	-0	+102	-0	+20	-0	+51	-0	—	—	—	—	—	—	—	—
48	—	1219.2	—	+50	-0	+127	-0	+30	-0	+76	-0	—	—	—	—	—	—	—	—

Table 15

Cup O.D.				Class 4				Class 3				Class 0				Class 00			
inch		mm		.0001 inch		.001 mm		.0001 inch		.001 mm		.0001 inch		.001 mm		.0001 inch		.001 mm	
Over	Incl.	Over	Incl.	High	Low	High	Low	High	Low	High	Low	High	Low	High	Low	High	Low	High	Low
—	12	—	304.8	+10	-0	+25	-0	+5	-0	+13	-0	+5	-0	+13	-0	+3	-0	+8	-0
12	24	304.8	609.6	+20	-0	+51	-0	+10	-0	+25	-0	—	—	—	—	—	—	—	—
24	36	609.6	914.4	+30	-0	+76	-0	+15	-0	+38	-0	—	—	—	—	—	—	—	—
36	48	914.4	1219.2	+40	-0	+102	-0	+20	-0	+51	-0	—	—	—	—	—	—	—	—
48	—	1219.2	—	+50	-0	+127	-0	+30	-0	+76	-0	—	—	—	—	—	—	—	—

Table 16

Cone Bore				Cup O.D.				Class 4				Class 3				Class 0, 00			
inch		mm		.0001 inch		.001 mm		.0001 inch		.001 mm		.0001 inch		.001 mm		.0001 inch		.001 mm	
Over	Incl.	Over	Incl.	High	Low	High	Low	High	Low	High	Low	High	Low	High	Low	High	Low	High	Low
—	4	—	101.6	—	—	—	—	+80	-0	+203	-0	+80	-80	+203	-203	+80	-80	+203	-203
4	12	101.6	304.8	—	—	—	—	+140	-1	+356	-254	+80	-80	+203	-203	+80	-80	+203	-203
12	24	304.8	609.6	—	-20	—	-508	+150	-150	+381	-381	+80	-80	+203	-203	—	—	—	—
12	24	304.8	609.6	+20	—	+508	—	+150	-150	+381	-381	+150	-150	+381	-381	—	—	—	—
24	—	609.6	—	—	—	—	—	+150	-150	+381	-381	+150	-150	+381	-381	—	—	—	—

Table 17

Cup O.D.				Class 4		Class 3		Class 0		Class 00	
inch		mm		.0001 inch	.001 mm	.0001 inch	.001 mm	.0001 inch	.001 mm	.0001 inch	.001 mm
Over	Incl.	Over	Incl.								
—	12	—	304.8	20	51	3	8	1.5	4	.75	2
12	24	304.8	609.6	20	51	7	18	—	—	—	—
24	36	609.6	914.4	30	76	20	51	—	—	—	—
36	—	914.4	—	30	76	30	76	—	—	—	—

Standard tolerance values for radial internal clearance of single row deep groove ball bearings with cylindrical bore.



Table 18 (Clearance Limits in 0.001 mm)

SINGLE ROW DEEP GROOVE BALL BEARINGS (CYLINDRICAL BORE)									
Nominal Bore d mm		C2 Less than Normal Clearance		— Normal Clearance		C3 Greater than Normal Clearance		C4 Greater than C3 Clearance	
<i>Over</i>	<i>Incl.</i>	<i>Low</i>	<i>High</i>	<i>Low</i>	<i>High</i>	<i>Low</i>	<i>High</i>	<i>Low</i>	<i>High</i>
—	2.5	—	6	4	11	10	20	—	—
2.5	10.0	—	7	2	13	8	23	—	—
10.0	18.0	—	9	3	18	11	25	18	33
18.0	24.0	—	10	5	20	13	28	20	36
24.0	30.0	—	11	5	20	13	28	23	41
30.0	40.0	—	11	6	20	15	33	28	46
40.0	50.0	—	11	6	23	18	36	30	51
50.0	65.0	—	15	8	28	23	43	38	61
65.0	80.0	—	15	10	30	25	51	46	71
80.0	100.0	—	18	12	36	30	58	53	84
100.0	120.0	—	20	15	41	36	66	61	97
120.0	140.0	—	23	18	48	41	81	71	114
140.0	160.0	—	23	18	53	46	91	81	130
160.0	180.0	—	25	20	61	53	102	91	147
180.0	200.0	—	30	25	71	63	117	107	163

Table 18-A (Clearance Limits in 0.0001 inch)

SINGLE ROW DEEP GROOVE BALL BEARINGS (CYLINDRICAL BORE)									
Nominal Bore d inch		C2 Less than Normal Clearance		— Normal Clearance		C3 Greater than Normal Clearance		C4 Greater than C3 Clearance	
<i>Over</i>	<i>Incl.</i>	<i>Low</i>	<i>High</i>	<i>Low</i>	<i>High</i>	<i>Low</i>	<i>High</i>	<i>Low</i>	<i>High</i>
—	.0984	—	2.4	1.6	4.3	3.9	7.9	—	—
.0984	.3937	—	2.8	.8	5.1	3.1	9.1	—	—
.3937	.7087	—	3.5	1.2	7.1	4.3	9.8	7.1	13.0
.7087	.9449	—	3.9	2.0	7.9	5.1	11.0	7.9	14.2
.9449	1.1811	—	4.3	2.0	7.9	5.1	11.0	9.1	16.1
1.1811	1.5748	—	4.3	2.4	7.9	5.9	13.0	11.0	18.1
1.5748	1.9685	—	4.3	2.4	9.1	7.1	14.2	11.8	20.1
1.9685	2.5591	—	5.9	3.1	11.0	9.1	16.9	15.0	24.0
2.5591	3.1496	—	5.9	3.9	11.8	9.8	20.1	18.1	28.0
3.1496	3.9370	—	7.1	4.7	14.2	11.8	22.8	20.9	33.1
3.9370	4.7244	—	7.9	5.9	16.1	14.2	26.0	24.0	38.2
4.7244	5.5118	—	9.1	7.1	18.9	16.1	31.9	28.0	44.9
5.5118	6.2993	—	9.1	7.1	20.9	18.1	35.8	31.9	51.2
6.2992	7.0866	—	9.8	7.9	24.0	20.9	40.2	35.8	57.9
7.0866	7.8740	—	11.8	9.8	28.0	24.8	46.1	42.1	64.2

RADIAL CLEARANCE COMPENSATION VALUES

Table 19 (Clearance Limits in 0.001 mm)

Nominal Bore d mm			Measuring Load (kg)	Clearance			
<i>Over</i>	<i>Incl.</i>			C2	Normal	C3	C4
10	18	2.5	3~4	4	4	4	
18	50	5	4~5	5	6	6	

Table 19-A (Clearance Limits in 0.0001 inch)

Nominal Bore d inch			Measuring Load (lbs)	Clearance			
<i>Over</i>	<i>Incl.</i>			C2	Normal	C3	C4
.3937	.7087	5.5	1.2~1.6	1.6	1.6	1.6	
.7087	1.9685	11	1.6~2.0	2.0	2.4	2.4	

REMARKS:

When measuring radial internal clearance, a slight amount of elastic deformation of the bearing occurs. The resulting measured clearance is slightly larger than the true clearance, and must be accounted for. These compensation values are given in tables 19 and 19-A.



Standard tolerance values for radial internal clearance of cylindrical roller bearings with cylindrical bore and interchangeable component.

Table 20 (Clearance Limits in 0.001 mm)

CYLINDRICAL ROLLER BEARINGS (cylindrical bore; interchangeable component)											
Nominal Bore <i>d</i> mm		C2 Less than Normal Clearance		Normal Clearance		C3 Greater than Normal Clearance		C4 Greater than C3 Clearance		C5 Greater than C4 Clearance	
<i>Over</i>	<i>Incl.</i>	<i>Min</i>	<i>Max</i>	<i>Min</i>	<i>Max</i>	<i>Min</i>	<i>Max</i>	<i>Min</i>	<i>Max</i>	<i>Min</i>	<i>Max</i>
—	10	0	25	20	45	35	60	50	75	—	—
10	24	0	25	20	45	35	60	50	75	65	90
24	30	0	25	20	45	35	60	50	75	70	95
30	40	5	30	25	50	45	70	60	85	80	105
40	50	5	35	30	60	50	80	70	100	95	125
50	65	10	40	40	70	60	90	80	110	110	140
65	80	10	45	40	75	65	100	90	125	130	165
80	100	15	50	50	85	75	110	105	140	155	190
100	120	15	55	50	90	85	125	125	165	180	220
120	140	15	60	60	105	100	145	145	190	200	245
140	160	20	70	70	120	115	165	165	215	225	275
160	180	25	75	75	125	120	170	170	220	250	300
180	200	35	90	90	145	140	195	195	250	275	330
200	225	45	105	105	165	160	220	220	280	305	365
225	250	45	110	110	175	170	235	235	300	330	395
250	280	55	125	125	195	190	260	260	330	370	440
280	315	55	130	130	205	200	275	275	350	410	485
315	355	65	145	145	225	225	305	305	385	455	535
355	400	100	190	190	280	280	370	370	460	510	600
400	450	110	210	210	310	310	410	410	510	565	665
450	500	110	220	220	330	330	440	440	550	625	735

Table 20-A (Clearance Limits in 0.0001 inch)

CYLINDRICAL ROLLER BEARINGS (cylindrical bore; interchangeable component)											
Nominal Bore <i>d</i> inch		C2 Less than Normal Clearance		Normal Clearance		C3 Greater than Normal Clearance		C4 Greater than C3 Clearance		C5 Greater than C4 Clearance	
<i>Over</i>	<i>Incl.</i>	<i>Min</i>	<i>Max</i>	<i>Min</i>	<i>Max</i>	<i>Min</i>	<i>Max</i>	<i>Min</i>	<i>Max</i>	<i>Min</i>	<i>Max</i>
—	0.3937	0.000	9.843	7.874	17.717	13.780	23.622	19.685	29.528	—	—
0.3937	0.9449	0.000	9.843	7.874	17.717	13.780	23.622	19.685	29.528	25.591	35.433
0.9449	1.1811	0.000	9.843	7.874	17.717	13.780	23.622	19.685	29.528	27.559	37.402
1.1811	1.5748	1.969	11.811	9.843	19.685	17.717	27.559	23.622	33.465	31.496	41.339
1.5748	1.9685	1.969	13.780	11.811	23.622	19.685	31.496	27.559	39.370	37.402	49.213
1.9685	2.5591	3.937	15.748	15.748	27.559	23.622	35.433	31.496	43.307	43.307	55.118
2.5591	3.1496	3.937	17.717	15.748	29.528	25.591	43.307	35.433	49.213	51.181	64.961
3.1496	3.9370	5.906	19.685	19.685	33.465	29.528	43.307	41.339	55.118	61.024	74.803
3.9370	4.7244	5.906	21.654	19.685	35.433	33.465	49.213	49.213	64.961	70.866	86.614
4.7244	5.5118	5.906	23.622	23.622	41.339	39.370	57.087	57.087	74.803	78.740	96.457
5.5118	6.2992	7.874	27.559	27.559	47.244	45.276	64.961	64.961	84.646	88.583	108.268
6.2992	7.0866	9.843	29.528	29.528	49.213	47.244	66.929	66.929	86.614	98.425	118.110
7.0866	7.8740	13.780	35.433	35.433	57.087	55.118	76.772	76.772	98.425	108.268	129.921
7.8740	8.8583	17.717	41.339	41.339	64.961	62.992	86.614	86.614	110.236	120.079	143.701
8.8583	9.8425	17.717	43.307	43.307	68.898	66.929	92.520	92.520	118.110	129.921	155.512
9.8425	11.0236	21.654	49.213	49.213	76.772	74.803	102.362	102.362	129.921	145.669	173.228
11.0236	12.4016	21.654	51.181	51.181	80.709	78.740	108.268	108.268	137.795	161.417	190.945
12.4016	13.9764	25.591	57.087	57.087	88.583	88.583	120.079	120.079	151.575	179.134	210.630
13.9764	15.7480	39.370	74.803	74.803	110.236	110.236	145.669	145.669	181.102	200.787	236.220
15.7480	17.7165	43.307	82.677	82.677	122.047	122.047	161.417	161.417	200.787	222.441	261.811
17.7165	19.6850	43.307	86.614	86.614	129.921	129.921	173.228	173.228	216.535	246.063	289.370

Standard tolerance values for radial internal clearance of cylindrical roller bearings with cylindrical bore and non-interchangeable component*

*(NA suffix designates non-interchangeable component)



Table 21 (Clearance Limits in 0.001 mm)

CYLINDRICAL ROLLER BEARINGS (cylindrical bore; non-interchangeable component)													
Nominal Bore d mm		C1 NA Less than C2 Clearance		C2 NA Less than Normal Clearance		NA Normal Clearance		C3 NA Greater than Normal Clearance		C4 NA Greater than C3 Clearance		C5 NA Greater than C4 Clearance	
Over	Incl.	Low	High	Low	High	Low	High	Low	High	Low	High	Low	High
18	24	5	10	10	20	20	30	35	45	45	55	65	75
24	30	5	10	10	25	25	35	40	50	50	60	70	80
30	40	5	12	12	25	25	40	45	55	55	70	80	95
40	50	5	15	15	30	30	45	50	65	65	80	95	110
50	65	5	15	15	35	35	50	55	75	75	90	110	130
65	80	10	20	20	40	40	60	70	90	90	110	130	150
80	100	10	25	25	45	45	70	80	105	105	125	155	180
100	120	10	25	25	50	50	80	95	120	120	145	180	205
120	140	15	30	30	60	60	90	105	135	135	160	200	230
140	160	15	35	35	65	65	100	115	150	150	180	225	260
160	180	15	35	35	75	75	110	125	165	165	200	250	285
180	200	20	40	40	80	80	120	140	180	180	220	275	315
200	225	20	45	45	90	90	135	155	200	200	240	305	350
225	250	25	50	50	100	100	150	170	215	215	265	330	380
250	280	25	55	55	110	110	165	185	240	240	295	370	420
280	315	30	60	60	120	120	180	205	265	265	325	410	470
315	355	30	65	65	135	135	200	225	295	295	360	455	520
355	400	35	75	75	150	150	225	255	330	330	405	510	585
400	450	45	85	85	170	170	255	285	370	370	455	565	650
450	500	50	95	95	190	190	285	315	410	410	505	625	720

Table 21-A (Clearance Limits in 0.0001 inch)

CYLINDRICAL ROLLER BEARINGS (cylindrical bore; non-interchangeable component)													
Nominal Bore d inch		C1 NA Less than C2 Clearance		C2 NA Less than Normal Clearance		NA Normal Clearance		C3 NA Greater than Normal Clearance		C4 NA Greater than C3 Clearance		C5 NA Greater than C4 Clearance	
Over	Incl.	Low	High	Low	High	Low	High	Low	High	Low	High	Low	High
.7087	.9449	2.0	3.9	3.9	7.9	7.9	11.8	13.6	17.7	17.7	21.7	25.6	29.5
.9449	1.1811	2.0	3.9	3.9	9.8	9.8	13.8	15.7	19.7	19.7	23.6	27.6	31.5
1.1811	1.5748	2.0	4.7	4.7	9.8	9.8	15.7	17.7	21.7	21.7	27.6	31.5	37.4
1.5748	1.9685	2.0	5.9	5.9	11.8	11.8	17.7	19.7	25.6	25.6	31.5	37.4	43.3
1.9685	2.5591	2.0	5.9	5.9	13.8	13.8	19.7	21.7	29.5	29.5	35.4	43.3	51.2
2.5591	3.1496	3.9	7.9	7.9	15.7	15.7	23.6	27.6	35.4	35.4	43.3	51.2	59.1
3.1496	3.9370	3.9	9.8	9.8	17.7	17.7	27.6	31.5	41.3	41.3	49.2	61.0	70.9
3.9370	4.7244	3.9	9.8	9.8	19.7	19.7	31.5	37.4	47.2	47.2	57.1	70.9	80.7
4.7244	5.5118	5.9	11.8	11.8	23.6	23.6	35.4	41.3	53.1	53.1	63.0	78.7	90.6
5.5118	6.2992	5.9	13.8	13.8	25.6	25.6	39.4	45.3	59.1	59.1	70.9	88.6	102.4
6.2992	7.0866	5.9	13.8	13.8	29.5	29.5	43.3	49.2	65.0	65.0	78.7	98.4	112.2
7.0866	7.8740	7.9	15.7	15.7	31.5	31.5	47.2	55.1	70.9	70.9	86.6	108.3	124.0
7.8740	8.8583	7.9	17.7	17.7	35.4	35.4	53.1	61.0	78.7	78.7	94.5	120.1	137.8
8.8583	9.8425	9.8	19.7	19.7	39.4	39.4	59.1	66.9	84.6	84.6	104.3	129.9	149.6
9.8425	11.0236	9.8	21.7	21.7	43.3	43.3	65.0	72.8	94.5	94.5	116.1	145.7	165.4
11.0236	12.4016	11.8	23.6	23.6	47.2	47.2	70.9	80.7	104.3	104.3	128.0	161.4	185.0
12.4016	13.9764	11.8	25.6	25.6	53.1	53.1	78.7	88.6	116.1	116.1	141.7	179.1	204.7
13.9764	15.7480	13.8	29.5	29.5	59.1	59.1	88.6	100.4	129.9	129.9	159.4	200.8	230.3
15.7480	17.7165	17.7	33.5	33.5	66.9	66.9	100.4	112.2	145.7	145.7	179.1	222.4	255.9
17.7165	19.6850	19.7	37.4	37.4	74.8	74.8	112.2	124.0	161.4	161.4	198.8	246.1	283.5



Standard tolerance values for radial internal clearance of spherical roller bearings with cylindrical bore.

Table 22 (Clearance Limits in 0.001 mm)

SPHERICAL ROLLER BEARINGS (cylindrical bore)									
Nominal Bore <i>d</i> mm		C2 Less than Normal Clearance		— Normal Clearance		C3 Greater than Normal Clearance		C4 Greater than C3 Clearance	
<i>Over</i>	<i>Incl.</i>	<i>Low</i>	<i>High</i>	<i>Low</i>	<i>High</i>	<i>Low</i>	<i>High</i>	<i>Low</i>	<i>High</i>
30	40	15	30	30	45	45	60	60	80
40	50	20	35	35	55	55	75	75	100
50	65	20	40	40	65	65	90	90	120
65	80	30	50	50	80	80	110	110	145
80	100	35	60	60	100	100	135	135	180
100	120	40	75	75	120	120	160	160	210
120	140	50	95	95	145	145	190	190	240
140	160	60	110	110	170	170	220	220	280
160	180	65	120	120	180	180	240	240	310
180	200	70	130	130	200	200	260	260	340
200	225	80	140	140	220	220	290	290	380
225	250	90	150	150	240	240	320	320	420
250	280	100	170	170	260	260	350	350	460
280	315	110	190	190	280	280	370	370	500
315	355	120	200	200	310	310	410	410	550
355	400	130	220	220	340	340	450	450	600
400	450	140	240	240	370	370	500	500	660
450	500	140	260	260	410	410	550	550	720
500	560	150	280	280	440	440	600	600	780
560	630	170	310	310	480	480	650	650	850
630	710	190	350	350	530	530	700	700	920
710	800	210	390	390	580	580	770	770	1010
800	900	230	430	430	650	650	860	860	1120
900	1000	260	480	480	710	710	930	930	1220

Table 22-A (Clearance Limits in 0.0001 inch)

SPHERICAL ROLLER BEARINGS (cylindrical bore)									
Nominal Bore <i>d</i> inch		C2 Less than Normal Clearance		— Normal Clearance		C3 Greater than Normal Clearance		C4 Greater than C3 Clearance	
<i>Over</i>	<i>Incl.</i>	<i>Low</i>	<i>High</i>	<i>Low</i>	<i>High</i>	<i>Low</i>	<i>High</i>	<i>Low</i>	<i>High</i>
1.1811	1.5748	5.9	11.8	11.8	17.7	17.7	23.6	23.6	31.5
1.5748	1.9685	7.9	13.8	13.8	21.7	21.7	29.5	29.5	39.4
1.9685	2.5591	7.9	15.7	15.7	25.6	25.6	35.4	35.4	47.2
2.5591	3.1496	11.8	19.7	19.7	31.5	31.5	43.3	43.3	57.1
3.1496	3.9370	13.8	23.6	23.6	39.4	39.4	53.1	53.1	70.9
3.9370	4.7244	15.7	29.5	29.5	47.2	47.2	63.0	63.0	82.7
4.7244	5.5118	19.7	37.4	37.4	57.1	57.1	74.8	74.8	94.5
5.5118	6.2992	23.6	43.3	43.3	66.9	66.9	86.6	86.6	110.2
6.2992	7.0866	25.6	47.2	47.2	70.9	70.9	94.5	94.5	122.0
7.0866	7.8740	27.6	51.2	51.2	78.7	78.7	102.4	102.4	133.9
7.8740	8.8583	31.5	55.1	55.1	86.6	86.6	114.2	114.2	149.6
8.8583	9.8425	35.4	59.1	59.1	94.5	94.5	126.0	126.0	165.4
9.8425	11.0236	39.4	66.9	66.9	102.4	102.4	137.8	137.8	181.1
11.0236	12.4016	43.3	74.8	74.8	110.2	110.2	145.7	145.7	196.9
12.4016	13.9764	47.2	78.7	78.7	122.0	122.0	161.4	161.4	216.5
13.9764	15.7480	51.2	86.6	86.6	133.9	133.9	177.2	177.2	236.2
15.7480	17.7165	55.1	94.5	94.5	145.7	145.7	196.9	196.9	259.8
17.7165	19.6850	55.1	102.4	102.4	161.4	161.4	216.5	216.5	283.5
19.6850	22.0472	59.1	110.2	110.2	173.2	173.2	236.2	236.2	307.1
22.0472	24.8031	66.9	122.0	122.0	189.0	189.0	255.9	255.9	334.6
24.8031	27.9528	74.8	137.8	137.8	208.7	208.7	275.6	275.6	362.2
27.9528	31.4961	82.7	153.5	153.5	228.3	228.3	303.1	303.1	397.6
31.4961	35.4331	90.6	169.3	169.3	255.9	255.9	338.6	338.6	440.9
35.4331	39.3701	102.4	189.0	189.0	279.5	279.5	366.1	366.1	480.3

Standard tolerance values for radial internal clearance of spherical roller bearings with tapered bore.

Table 23 (Clearance Limits in 0.001 mm)



SPHERICAL ROLLER BEARINGS (TAPERED BORE)									
Nominal Bore <i>d</i> mm		C2 Less than Normal Clearance		— Normal Clearance		C3 Greater than Normal Clearance		C4 Greater than C3 Clearance	
<i>Over</i>	<i>Incl.</i>	<i>Low</i>	<i>High</i>	<i>Low</i>	<i>High</i>	<i>Low</i>	<i>High</i>	<i>Low</i>	<i>High</i>
30	40	25	35	35	50	50	65	65	85
40	50	30	45	45	60	60	80	80	100
50	65	40	55	55	75	75	95	95	120
65	80	50	70	70	95	95	120	120	150
80	100	55	80	80	110	110	140	140	180
100	120	65	100	100	135	135	170	170	220
120	140	80	120	120	160	160	200	200	260
140	160	90	130	130	180	180	230	230	300
160	180	100	140	140	200	200	260	260	340
180	200	110	160	160	220	220	290	290	370
200	225	120	180	180	250	250	320	320	410
225	250	140	200	200	270	270	350	350	450
250	280	150	220	220	300	300	390	390	490
260	315	170	240	240	330	330	430	430	540
315	355	190	270	270	360	360	470	470	590
355	400	210	300	300	400	400	520	520	650
400	450	230	330	330	440	440	570	570	720
450	500	260	370	370	490	490	630	630	790
500	560	290	410	410	540	540	680	680	870
560	630	320	460	460	600	600	760	760	980
630	710	350	510	510	670	670	850	850	1090
710	800	390	570	560	750	750	960	960	1220
800	900	440	640	640	840	840	1070	1070	1370
900	1000	490	710	710	930	930	1190	1190	1520

Table 23-A (Clearance Limits in 0.0001 inch)

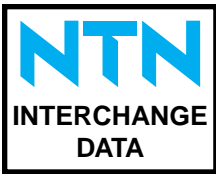
SPHERICAL ROLLER BEARINGS (TAPERED BORE)									
Nominal Bore <i>d</i> inch		C2 Less than Normal Clearance		— Normal Clearance		C3 Greater than Normal Clearance		C4 Greater than C3 Clearance	
<i>Over</i>	<i>Incl.</i>	<i>Low</i>	<i>High</i>	<i>Low</i>	<i>High</i>	<i>Low</i>	<i>High</i>	<i>Low</i>	<i>High</i>
1.1811	1.5748	9.8	13.8	13.8	19.7	19.7	25.6	25.6	33.5
1.5748	1.9685	11.8	17.7	17.7	23.6	23.6	31.5	31.5	39.4
1.9685	2.5591	15.7	21.7	21.7	29.5	29.5	37.4	37.4	47.2
2.5591	3.1496	19.7	27.6	27.6	37.4	37.4	47.2	47.2	59.1
3.1496	3.9370	21.7	31.5	31.5	43.3	43.3	55.1	55.1	70.9
3.9370	4.7244	25.6	39.4	39.4	53.1	53.1	66.9	66.9	86.6
4.7244	5.5118	31.5	47.2	47.2	63.0	63.0	78.7	78.7	102.4
5.5118	6.2992	35.4	51.2	51.2	70.9	70.9	90.6	90.6	118.1
6.2992	7.0866	39.4	55.1	55.1	78.7	78.7	102.4	102.4	133.9
7.0866	7.8740	43.3	63.0	63.0	86.6	86.6	114.2	114.2	145.7
7.8740	8.8583	47.2	70.9	70.9	98.4	98.4	126.0	126.0	161.4
8.8583	9.8425	55.1	78.7	78.7	106.3	106.3	137.8	137.8	177.2
9.8425	11.0236	59.1	86.6	86.6	118.1	118.1	153.5	153.5	192.9
11.0236	12.4016	66.9	94.5	94.5	129.9	129.9	169.3	169.3	212.6
12.4016	13.9764	74.8	106.3	106.3	141.7	141.7	185.0	185.0	232.3
13.9764	15.7480	82.7	118.1	118.1	157.5	157.5	204.7	204.7	255.9
15.7480	17.7165	90.6	129.9	129.9	173.2	173.2	224.4	224.4	283.5
17.7165	19.6850	102.4	145.7	145.7	192.9	192.9	248.0	248.0	311.0
19.6850	22.0472	114.2	161.4	161.4	212.6	212.6	267.7	267.7	342.5
22.0472	24.8031	126.0	181.1	181.1	236.2	236.2	299.2	299.2	385.8
24.8031	27.9528	137.8	200.8	200.8	263.8	263.8	334.6	334.6	429.1
27.9528	31.4961	153.5	224.4	224.4	295.3	295.3	378.0	378.0	480.3
31.4961	35.4331	173.2	252.0	252.0	330.7	330.7	421.3	421.3	539.4
35.4331	39.3701	192.9	279.5	279.5	366.1	366.1	468.5	468.5	598.4

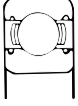

SEALS, SHIELDS, AND SNAP RINGS

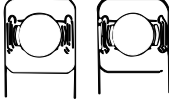
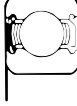
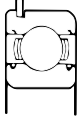
						
	Open type	Single shielded	Double shielded	Double sealed	Single shielded sealed	With snap ring
NTN Suffix	Z	ZZ	LLB or LLU	LBZ or LUZ	NR	
BARDEN Suffix	S	SS	FF	—	—	
BCA Suffix	S	SS	DD	DS	L	
FAFNIR Suffix	D	DD	PP	PD	G	
FAG Suffix	Z	ZZ	2RS	RSZ	NR	
MRC Suffix	F	FF	ZZ	ZF	G	
NDH Prefix	7	77	99	97	4	
NSK Suffix	Z	ZZ	VV OR DDU	VZ OR DUZ	NR	
SKF Suffix	Z	ZZ	2RS	RSZ	NR	

SUFFIXES FOR SUPER PRECISION BEARINGS

MFG	ABEC-3 ISO CLASS 6	ABEC-5 ISO CLASS 5	ABEC-7 ISO CLASS 4	ABEC-9 ISO CLASS 2
NTN	P6	P5	P4	P2
BARDEN	—	ABEC5	ABEC7	ABEC9
FAFNIR	M*	V*	MM*	MMX*
FAG	P6	P5	P4	P2
MRC	—	ABEC-5	ABEC-7	ABEC-9
NDH	3	5	7	9
NSK	P6	P5	P4	P2
SKF	P6	P5	P4	PA9A

* These are prefixes

RADIAL BALL BEARINGS								
NTN	BARDEN	BCA	FAFNIR	FAG	MRC	NDH	NSK	SKF
634	34K	34	34K	634	34	34	R4B	
635	35K	35	35K	635	35	35	R5B	
626	36K	36	36K	626	36	36	R6B	
627	37K	37	37K	627	37	37	R7	
608	38K	38	38K	608	38	38	R8	
629	39K	39	39K	629	39	39	R9	
6000	100K	100	9100K	6000	100KS	3L00	6000	
6200	200	200	200K	6200	200S	3200	6200	
6300	—	300	300K	6300	300S	3300	6300	
BL200	—	1200	200W	200	200M	1200	200	
BL300	—	1300	300W	300	300M	1300	300	
8000	—	8000	30KL	8000	30FS	8000	—	—
87000	—	87000	30KLD	87000	30FSF	87000	—	—
88000	—	88000	30KLL	88000	30FFS	88000	—	—
8500	—	8500	200KL	8500	200FS	8500	—	—
87500	—	87500	200KLD	87500	200FSF	87500	—	—
88500	—	88500	200KLL	88500	200FFS	88500	—	—
63200	9200	—	W200PP	S3500	200SFFC	—	—	462200
63300	9300	—	W300PP	S3600	300SFFC	—	—	462300
6900	—	—	9300K	61900	1900S	3LL00	6900	61900
R2	—	—	33K3	R2	R-2	R2	R2	—
RA2	SR2A	—	33K4	RA2	R-2A	R2A	R2A	EE-0
R3	SR3K	—	33K5	R3	R-3	R3	R3	EE-1
RA3Z	SR3S	—	33KD5	R3-Z	R-3-FM	7R3	R3Z	—
R188	SR188K	—	—	—	—	—	R188	—
EE2	SR4A	—	S1K	R4A	R-4A-4	R4A	EE2	EE-2
EE3	SR6K	—	S3K	R6	R-6	R6	EE3	EE-3
R4	SR4K	R4SS	S1K7	R4	R-4	R4	R4	—
RA4Z	SR4AS	—	S1KD	R4-A-Z	R-4-AF	7R4A	R4Z	—
R6Z	SR6S	R6SS	S3KD	R6-Z	R-6-F	7R6	R6Z	—
R8Z	SR8S	R8SS	S5KD	R8-Z	R-8-F	7R8	R8Z	—
R10Z	SR10S	R10S	S7KD	R10-Z	R-10-F	7R10	R10Z	—
R12Z	—	R12S	S8KD	R12-Z	R-12-F	7R12	R12Z	—
R14Z	—	R14S	—	R14-Z	R-14-F	7R14	R14Z	—
R16Z	—	R16S	—	R16-Z	R-16-F	7R16	R16Z	—
R18Z	—	—	—	R18-Z	R-18-F	7R18	R18Z	—
R20Z	—	—	—	R20-Z	—	7R20	R20Z	—

ANGULAR AND SELF ALIGNING BALL BEARINGS								
NTN	BARDEN	BCA	FAFNIR	FAG	MRC	NDH	NSK	SKF
7000	2100H	—	7100PW	7000	7100KR	0L00	7000	7100
7200	2200H	7200	7200PW	7200	7200	20200	7200	7200
7300	2300H	7300	7300PW	7300	7300	20300	7300	7300
3200	—	5200	5200	3200	5200	5200	—	5200
5200	—	—	—	—	—	—	5200	—
3300	—	5300	5300	3300	5300	5300	—	5300
5300	—	—	—	—	—	—	5300	—
1200	—	—	L200	1200	—	2500	1200	1200
2200	—	—	L6200	2200	—	—	2200	2200
1300	—	—	L300	1300	—	2600	1300	1300
2300	—	—	L6300	2300	—	—	2300	2300

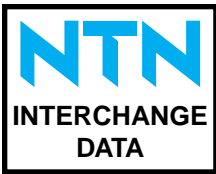

CYLINDRICAL ROLLER BEARINGS							
NTN	BCA or BOWER	FAG	NDH	NSK	ROLLWAY	SKF	TORRINGTON
NU1000	—	NU1000	A1000WB	NU1000	—	NU1000	—
NU200	MA1200EL	NU200	A1200WB	NU200	MUC200	NU200	000RU02
NJ200	MR1200EL	NJ200	R1200WB	NJ200	MUL200	NJ200	000RJ02
NH200	—	—	PR1200WB	NH200	MR200	NH200	—
NUP200	MSN1200EX	NUP200	—	NUP200	MU200	NUP200	000RT02
N200	MU1200CL	N200	BU1200Z	N200	MCS200	N200	000RN02
NF200	MU1200DL	NF200	BU1200L	NF200	ML200	NF200	000RF02
NU2200	—	NU2200	—	NU2200	—	NU2200	—
NU300	MA1300EL	NU300	A1300WB	NU300	MUC300	NU300	000RU03
NU2300	—	NU2300	—	NU2300	—	NU2300	—
NN3000	—	NN3000	—	NN3000	—	NN3000	—

SPHERICAL ROLLER BEARINGS					
NTN	FAG	PTC- LINKBELT	NSK	SKF	TORRINGTON
23900	23900	—	23900	23900	23900
23000	23000	23000LB	23000	23000	23000
24000	24000	—	24000	24000	24000
23100	23100	23100LB	23100	23100	23100
24100	24100	—	24100	24100	24100
22200	22200	22200LB	22200	22200	22200
23200	23200	23200LB	23200	23200	23200
21300	21300	—	21300	21300	21300
22300	22300	22300LB	22300	22300	22300
29300	29300	—	29300	29300	29300
29400	29400	—	29400	29400	29400

THRUST BALL BEARINGS							
NTN	AETNA	ANDREWS	FAFNIR	FAG	MRC	NSK	SKF
51100	—	51100	—	51100	—	51100	51100
51200	—	51200	—	51200	—	51200	51200
900	1100	900	N1800	—	1100F	—	900
2900	1000	2900	1500	—	2900	—	2900

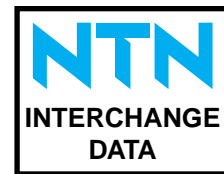

MOUNTED UNITS AND INSERT BEARINGS

NTN	HUB-CITY	DODGE	FAFNIR	NSK	PTC-LINKBELT	SEALMASTER	SKF
UCP	PB251*	SC	RASC	UCP	P3-U	NP	SY
UCPL	PB250	SCB	—	—	PL3-U	S-500M	—
UEL	PB221	SX	RAS	EWP	P3-Y	—	—
UELPL	PB220	SXB	RAK	—	PL3-Y	—	SYH-X
UCPX	PB350	SCM	RAKH	—	—	MP	—
ASPP	—	SL	—	UBPP	—	SSP	—
ASRPP	—	—	—	UBPPR	—	LRP	—
AELPP	—	SLX	PB	ENPP	—	—	SP
AELRPP	—	—	RPB	—	—	—	SRP
UCF	FB250*	SC	RCJC	UCF	F3-U	SF	FY
UCFL	FB260	SC	RCJTC	UCFL	FX3-U	SFT	—
UELFU	FB220	SX	RCJ	—	F3-Y	—	FY-X
UELFU	FB230	SX	RCJT	—	FX3-Y	—	—
UCFX	FB350	SCM	RCJO	—	—	MSF	—
UCFLX	—	SCM	—	—	—	MSFT	—
AELFD	—	—	FLCT	—	—	—	—
ASPF	—	SL	—	UBPF	—	SSF	—
ASPFL	—	SL	—	UBPFL	—	SSFT	—
AELPF	—	SLX	RA	ENPF	—	—	FP
AELPFL	—	SLX	RAT	ENPFL	—	—	FTP
AS	B100	—	—	UB	—	L	—
AEL	B200	—	RA-NPPB	EN	W200U	—	478200
UC	B250	—	GC-KRRB	UC	UG200NL	2-000	479200
UEL	B220	—	G-KRRB	EW	YG200N	—	477200
UCX	B350	—	—	—	—	3-000	—
ASS	—	—	—	—	—	SL	—
AELS	—	—	RA-NPP	—	WB200U	—	—
UCS	—	—	GC-KRRG	UR	UBG200NL	ER	—
UELS	—	—	G-KRR	—	YGB200N	—	—

SAF and SAFS PILLOW BLOCKS

NTN	PTC-LINKBELT	SKF	TORRINGTON
SAF22500	P-LB6800(F)H	SAF22500	SAF22500A
SAF22600	P-LB6900(F)H	SAF22600	SAF22600A
SAF22200	P-LB7800(F)H	SAF22200	SAF22200
SAF22300	P-LB7900(F)H	SAF22300	SAF22300
SAF22500B6	P-LB6800FH	FSAF22500	FSAF22500A
SAFS22500	PK-LB6800FH	SAFS22500	SAFS22500A
SAFS22200	PK-LB7800FH	SAFS22200	SAFS22200

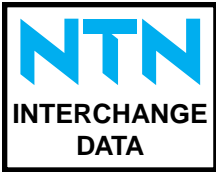

DISC HARROW BEARINGS			
NTN	FAFNIR	NDH	BCA
1AS08-7/8	W208PPB13	AS4508FF	DS208TT13
4AS08-7/8	W208PPB11	AS4508FC	DS208TT11
4AS08-7/8	W208PPB18	AS4508H	DS208TT11A
1AS08-1	W208PPB6	AS4508BK	DS208TT6
1AS08-1D1	GW208PPB6	RAS4508AE	DS208TTR6
2AS08-1	W208PPB9	AS4508BE	DS208TT9
4AS08-1	—	AS4508AC	DS208TTB
1AS08-1.1/8	W208PPB5	AS4508BJ	DS208TT5
2AS08-1.1/8	W208PPB8	AS4508EF	DS208TT8
2AS08-1.1/8D1	GW208PPB8	RAS4508EF	DS208TTR8
4AS08-1.1/8	W208PPB12	AS4508BC	DS208TT12B
4AS08-1.1/8	W208PPB19	AS4508F	DS208TT12A
1AS08-1.5/32D1	GW208PPB5	—	DS208TTR5
2AS09-1.1/4	W209PPB5	AS4509A	DS209TT5
4AS09-1.1/4	W209PPB7	AS4509AC	DS209TT7
2AS10-1.1/8	W210PPB6	—	—
3AS10-1.1/8	W210PPB4	—	DS210TT4
3AS11-1.1/2	W211PPB3	AS4511BE	DS211TT3
3AS11-1.1/2D1	GW211PPB3	RAS4511BE	DS211TTR3
4AS11-1.1/2	W211PPB6	AS4511AC	DS11TT6
3AS14-2.1/32D1	GW214PPB4	—	—
5AS08-1.1/8	W208PP5	AS4508BH	DC208TT5
6AS08-1.1/8	W208PP8	AS4508BD	DC208TT8
6AS09-1.1/4	—	AS4509AD	DC209TT5
6AS09-1.1/4D1	—	RAS4509AD	DC209TTR5
7AS10-1.1/8D1	GW210PP4	RAS4510B	DC210TTR4
6AS11-1.1/2V1	W211PP5	AS4511AE	DC211TT5
7AS11-1.1/2	W211PP3	AS4511BD	DC211TT3
7AS11-1.1/2D1	GW211PP3	RAS4511BD	DC211TTR3
1AC08-1.3/16	W208PPB7	—	DS208TT7
2AC08-1.1/2	W208PPB2	—	DS208TT2A
1AC09D1V1	GW209PPB11	—	DS209TTR10
3AC09	W209PPB2	AS4509BE	DS209TT2
3AC09D1	GW209PPB2	RAS4509BE	DS209TTR2
3AC09-1.1/2	W209PPB4	AS4509BD	DS209TT4
3AC09-1.1/2D1	GW209PPB4	RAS4509BD	DS209TTR4
3AC10-1.3/4	W210PPB5	—	DS210TT5
3AC10-1.3/4D1	GW210PPB5	—	DS210TTR5
3AC10-1.15/16	W210PPB2	—	DS210TT2
3AC10-1.15/16D1	GW210PPB2	—	DS210TTR2
1AC11-2.3/16D1V1	GW211PPB9	—	DS211TTR9
3AC11-2.3/16	W211PPB2	—	DS211TT2
3AC11-2.3/16D1	GW211PPB2	—	DS211TTR2
3AC14D1	GW214PPB2	—	—
5AC10-1.15/16V1	RM1115K	3210B	DC210
7AC10-1.15/16	W210PP2	—	DC210TT2
7AC11-2.3/16D1	GW211PP2	RAS4511C	DC211TTR2

HEX BORE BEARINGS

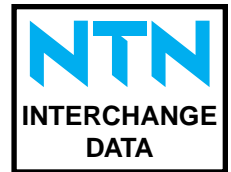

NTN	FAFNIR	NDH	BCA
1AH04-11/16	204KRR2	—	—
1AH05-7/8	205KRR2	—	HPC014GP
2AH05-7/8	205KRRB2	—	HPS014GP
1AH06-1	206KRR6	88506J	HPC100GP
2AH06-1	206KRRB6	88506H	HPS100GP
2AH06-1D1	G206KRRB6	—	—
2AH07-1.1/8	207KRRB9	—	HPS102GP
2AH08-1.1/4V2	W208PPB16	—	—
2AH09-1.1/2	209KRRB2	—	—



ENGLISH/METRIC CONVERSION CHART

WEIGHT			
1 ounce	= 28.35 grams (g)	1 gram	= .03527 ounces (oz.)
1 ounce	= .02835 kilograms (kg)	1 gram	= .002205 pounds (lb.)
1 ounce	= .0625 pounds (lb.)	1 kilogram	= 35.274 ounces (oz.)
1 pound	= 16 ounces (oz.)	1 kilogram	= 2.2046 pounds (lb.)
1 pound	= 453.6 grams (g)	1 kg per sq. cm	= 14.223 lb. per sq. inch
1 pound	= .4536 kilograms (kg)	1 kg per sq. meter	= .2048 lb. per sq. foot
1 lb. per sq. inch	= .070307 kg per sq. cm	1 kg per sq. meter	= 1.8433 lb. per sq. yard
1 lb. per sq. foot	= 4.8824 kg per sq. meter	1 g per cu. cm	= .57803 oz. per cu. inch
1 lb. per sq. yard	= .54249 kg per sq. meter	1 kg per cu. meter	= .062428 lb. per cu. foot
1 oz per cu. inch	= 1.7300 g per cu. cm		
1 lb. per cu. foot	= 16.019 kg per cu. meters		

LENGTH			
1 inch	= 25.400 millimeters (mm)	1 millimeter	= .03937 inches (in.)
1 inch	= 2.54 centimeters (cm)	1 centimeter	= .3937 inches (in.)
1 inch	= .08333 feet (ft.)	1 centimeter	= .01094 yards (yd.)
1 inch	= .02778 yards (yd.)	1 meter	= 3.2809 feet (ft.)
1 foot	= 12 inches (in.)	1 meter	= 1.0936 yards (yd.)
1 foot	= .333 yards (yd.)	1 kilometer (km)	= 3,281 feet (ft.)
1 foot	= .30481 meters (m)	1 kilometer (km)	= 1,094 yards (yd.)
1 yard	= 36 inches (in.)	1 kilometer (km)	= .6214 statute mile
1 yard	= 3 feet (ft.)		
1 yard	= 91.44 centimeters (cm)		
1 yard	= .9144 meters (m)		
1 statute mile	= 5,280 feet (ft.)		
1 statute mile	= 1,760 yards (yd.)		
1 statute mile	= 1.6093 kilometers (km)		

AREA			
1 sq. inch	= 6.4516 sq. centimeters	1 sq. centimeter	= .15500 sq. inches
1 sq. inch	= .00694 sq. feet	1 sq. centimeter	= .00108 sq. feet
1 sq. foot	= 144 sq. inches	1 sq. meter	= 10.764 sq. feet
1 sq. foot	= 929.03 sq. centimeters	1 sq. meter	= 1.196 sq. yards
1 sq. foot	= .1111 sq. yards		
1 sq. foot	= .092903 sq. meters		
1 sq. yard	= 9 sq. feet		
1 sq. yard	= .83612 sq. meters		

VOLUME			
1 cu. inch	= .0005787 cu. feet	1 cu. centimeter	= .06102 cu. inches
1 cu. inch	= .017316 quarts (qt.)	1 cu. meter	= 61,023 cu. inches
1 cu. inch	= .004329 gallons (gal.)	1 cu. meter	= 35.31 cu. feet
1 cu. inch	= 16.39 cu. centimeters	1 cu. meter	= 1.30873 cu. yards
1 cu. inch	= .00001639 cu. meters	1 liter	= 61.017 cu. inches
1 cu. inch	= .0164 liters (l)	1 liter	= .03531 cu. feet
1 cu. foot	= 1,728 cu. inches	1 liter	= 2.11327 pints (pt.)
1 cu. foot	= .0370 cu. yards	1 liter	= 1.057 quarts (qt.)
1 cu. foot	= 29.9222 quarts (qt.)	1 liter	= .2642 gallons (gal.)
1 cu. foot	= 7.481 gallons (gal.)		
1 cu. foot	= .0283 cu. meters		
1 cu. foot	= 28.32 liters (l)		
1 cu. yard	= 27 cu. feet		
1 cu. yard	= .76410 cu. meters		
1 pint	= .50 quarts (qt.)		
1 pint	= .4732 liters (l)		
1 quart	= 2 pints (pt.)		
1 quart	= .25 gallons		
1 quart	= 57.75 cu. inches		
1 quart	= .03342 cu. feet		
1 quart	= .9464 liters (l)		
1 gallon	= 231 cu. inches		
1 gallon	= .1337 cu. feet		
1 gallon	= 4 quarts (qt.)		

ENERGY AND POWER			
1 foot-pound	= .13826 kilogrammeter	1 kilogrammeter	= 7.2330 foot-pounds (ft.-lb.)
1 foot-pound	= .001285 Btu	1 Btu	= 778.2 foot pounds (ft.-lb.)
1 ft.-lb. per sec.	= .00182 horsepower (hp.)	1 Btu per min.	= .02358 horsepower (hp.)
1 ft.-lb. per min.	= .0000303 horsepower (hp.)	1 kilowatt	= 1.341 horsepower (hp.)
1 horsepower	= 550 ft.-lb. per sec.		
1 horsepower	= 33,000 ft.-lb. per min.		
1 horsepower	= 42.41 Btu per min.		
1 horsepower	= .7457 kilowatts (kw)		



DECIMAL EQUIVALENTS

2,4	8	16	32	64	Decimal Inches	mm	mm	Inches
			1/32	1/64	.015625 .031250	.3969 .7938	26 27	1.02362 1.06299
		1/16		3/64	.046875 .062500	.039370 1 1.1906 1.5875	28 29 30	1.10236 1.14173 1.18110
			3/32	5/64	.078125	.078740	31 32	1.22047 1.25984
				7/64	.093750 .109375	2.3812 2.7781	33 34 35	1.29921 1.33858 1.37795
	1/8			9/64	.125000 .140625 .156250	.157480	36 37 38	1.41732 1.45669 1.49606
				11/64	.171875	4.3656	39 40	1.53543 1.57480
		3/16		13/64	.187500 .203125 .218750 .234375	.196850	41 42 43 44 45	1.61417 1.65354 1.69291 1.73228 1.77165
				15/64	.250000 .265625	.236220 .275591	46 47 48 49 50	1.81102 1.85039 1.88976 1.92913 1.96850
1/4				17/64	.281250	7.1438	51 52 53 54 55	2.00787 2.04724 2.08661 2.12598 2.16535
		5/16		19/64	.296875 .312500	.314961	56 57 58 59 60	2.20472 2.24409 2.28346 2.32283 2.36220
				21/64	.328125 .343750	.354331	61 62 63 64 65	2.40157 2.44094 2.48031 2.51969 2.55906
	3/8			23/64	.359375 .375000 .390625	.393701	66 67 68 69 70	2.59843 2.63780 2.67717 2.71654 2.75591
				25/64	.406250 .421875	.433071	71 72 73 74 75	2.79528 2.83465 2.87402 2.91339 2.95276
		7/16		27/64	.437500 .453125	.472441	76 77 78 79 80	2.99213 3.03150 3.07087 3.11024 3.14961
				29/64	.468750 .484375 .500000	.511811	81 82 83 84 85	3.18898 3.22835 3.26772 3.30708 3.34646
1/2				31/64	.515625 .531250 .546875 .562500	.551181	86 87 88 89 90	3.38583 3.42520 3.46457 3.50394 3.54331
				33/64	.578125	.590551	91 92 93 94 95	3.58268 3.62205 3.66142 3.70079 3.74016
				35/64	.593750 .609375 .625000	.629921	96 97 98 99 100	3.77953 3.81890 3.85827 3.89764 3.93701
		9/16		37/64	.640625 .656250	.669291	101 102 103 104 105	3.97645 4.01582 4.05519 4.09456 4.13393
				39/64	.671875	.708661	106 107 108 109 110	4.17330 4.21267 4.25204 4.29141 4.33078
	5/8			41/64	.687500 .703125	.748031	111 112 113 114 115	4.37015 4.40952 4.44889 4.48826 4.52763
				43/64	.718750 .734375	.787402	116 117 118 119 120	4.56700 4.60637 4.64574 4.68511 4.72448
		11/16		45/64	.748031	.826772	121 122 123 124 125	4.76385 4.80322 4.84259 4.88196 4.92133
				47/64	.762500 .778125	.866142	126 127 128 129 130	4.96070 4.99997 5.03924 5.07851 5.11778
3/4				49/64	.781250	.905512	131 132 133 134 135	5.15705 5.19632 5.23559 5.27486 5.31413
				51/64	.796875 .812500	.944882	136 137 138 139 140	5.35348 5.39275 5.43202 5.47129 5.51056
		13/16		53/64	.828125 .843750	.984252	141 142 143 144 145	5.54991 5.58918 5.62845 5.66772 5.70699
				55/64	.859375	.99512	146 147 148 149 150	5.74642 5.78569 5.82496 5.86423 5.90350
	7/8			57/64	.875000 .890625	.995512	151 152 153 154 155	5.94277 5.98204 6.02131 6.06058 6.10000
				59/64	.906250 .921875 .937500	.944882	156 157 158 159 160	6.23921 6.27848 6.31775 6.35702 6.39629
		15/16		61/64	.953125	24.2094	161 162 163 164 165	6.43564 6.47491 6.51418 6.55345 6.59272
				63/64	.968750 .984375	.984252	166 167 168 169 170	6.63207 6.67134 6.71061 6.74988 6.78915
				65/64	.981250 1.000000	24.6062 25 25.0031	171 172 173 174 175	6.82842 6.86769 6.90696 6.94623 6.98550

CATALOG #A1000 — GENERAL INDEX

NTN Terms and Conditions of Sale	2
Table of Contents.....	3
NTN Bearing Corporation of America.....	4-7
Bearing Classifications	8-9
Design and Characteristics.....	10-11

MICRO BEARING SERIES 12-15

Inch	13
Metric	15

RADIAL BALL BEARING SERIES 16-42

R	17
600	18
69	19
60	20-23
62	24-27
63	28-29
64	30
632, 633	31
BL2	32-33
BL3	34-35
TMB2	36-39
TMB3	40-41

ANGULAR CONTACT

BALL BEARING SERIES..... 43-56

72B	44
73B	45
74B	46
70	47
72	48
73	49
70C	50
72C	51
73C	52
BNT0, HSB0C	53
32, 33	54
52, 53	55
Double Row.....	56

SELF ALIGNING BALL BEARING SERIES .57-61

12, 12K.....	58
22, 22K.....	59
13, 13K.....	60
23, 23K.....	61

CYLINDRICAL ROLLER BEARING SERIES 62-74

N10, NU10	63
NF2, N2, NJ2, NU2, HJ2.....	64-65
NF3, N3, NJ3, NU3, HJ3.....	66-67
NF4, N4, NJ4, NU4, HJ4.....	68-69
NJ22, NU22, HJ22	70-71
NJ23, NU23, HJ23	72-73
NN30, NN30K	74

TAPERED ROLLER BEARING SERIES..... 75-105

4T-335 to 4T-395	76
4T-415 to 4T-535	77
4T-555 to 4T-635	78

4T-655 to 4T-935	79
4T-1300 to 4T-3400	80
4T-3500 to 4T-5300	81
4T-5500 to 4T-07000	82
4T-09000 to 4T-14000	83
4T-14000 to 4T-18500	84
4T-18600 to 4T-25800	85
4T-26800 to 4T-33000	86
4T-33800 to 4T-46700	87
4T-47600 to 4T-67300	88
4T-L68100 to 4T-LM102900	89
4T-LM104900 to 4T-LM506800	90
4T-LM508700 to 4T-M718100	91
4T-M719100 to 4T-HM903200.....	92
Basic Load Ratings	93
Bearing Weights	94-97
Metric ISO Series 4T-30208 to 4T-30313D	98
Metric ISO Series 30313U to 32026XU	99
Metric ISO Series 32028XU to 32238	100
Metric ISO Series 32240 to 32932XU.....	101
Metric ISO Series 32934XU to 33217U	102
Bearing Weights (Metric ISO Series)	103
Tapered Roller Bearing Cartridges	104
Tapered Roller Bearing Sets	105

SPHERICAL

ROLLER BEARING SERIES 106-119

213	107
222	108
223	109
230	110
231	111
232	112
239	113
240	114
241	115
223 UAVS1 – Shaker Screens	116
MX-W222 – Sealed.....	117
Bearing Weights	118-119

BEARING ADAPTERS..... 120-123

LOCKNUTS and LOCKWASHERS 124-126

BALL and ROLLER

THRUST BEARING SERIES 127-133

511	128
512	129
29	130
292, 293	131
294	132

MOUNTED UNITS 134-238

ULTRA CLASS SERIES..... 134-155

UCP	135
UCPL	136
UCPX	137
ARP	138
ARPL.....	139

CATALOG #A1000 — GENERAL INDEX

UELPL.....141	AR2.....208
JELP.....142	UCS2.....209
JELPL.....143	UCS3.....210
UCFLU.....144	UEL2.....211
UCFLUX.....145	UEL3.....212
ARFLU.....146	AEL2, AELS2.....213
UELFLU.....147	JEL2.....214
JELFLU.....148	REL2.....215
UCFU.....149	UK2.....216
UCFUX.....150	Bearing Weights.....217-219
UELFU.....151	Bearing Speed Limits.....220-221
ARFU.....152	DISC HARROW BEARING SERIES ... 222-223
JELFU.....153	1AS-7AS.....222
Bearing Weights.....154-155	1AC-7AC.....223
PILLOW BLOCK SERIES..... 156-173	HEX BORE BEARINGS SERIES224
UCP2.....156-157	1AH-3AH.....224
UCPL2.....158	HEAVY DUTY MOUNTED UNITS..... 225-237
UCP3.....159	SPW.....226-227
UCPX.....160-161	SPAW.....228-229
ASPL2.....162	SFCW.....230-231
ASPP2.....163	SAF.....232-235
UELPL2.....165	SAFS.....236-237
UELPL3.....166	TECHNICAL INFORMATION..... 239-252
JELPL2.....167	Bearing Materials.....240
AELP2.....168	Handling & Installation.....240-241
AELPL2.....169	Running Test.....241
AELPP2.....170	Dismounting.....241
UKP2.....171	Lubrication.....242
Bearing Weights.....172-173	Analysis of Bearing Operating Problems ...243-244
FLANGED UNIT SERIES 174-203	Bearing Nomenclature.....245-248
UCFL2.....174	Bearing Ratings and Fitting Practice.....249-252
UCFL3.....175	TOLERANCE TABLES 253-264
UCFLX.....176	CLEARANCE TABLES 265-269
UELFL2.....177	INTERCHANGE DATA 270-275
UELFL3.....178	Seals, Shields and Snap Rings.....270
UELFLU2.....179	Suffixes for Super Precision Bearings.....270
AELFL2.....180	Radial Ball Bearings.....271
JELFL2.....181	Angular & Self Aligning Ball Bearings.....271
ASFD2.....182	Cylindrical Roller Bearings.....272
AELFD2.....183	Spherical Roller Bearings.....272
JELFD2.....184	Thrust Ball Bearings.....272
ASPFL2.....185	Mounted Units & Insert Bearings.....273
AELPFL2.....186	SAF & SAFS Pillow Blocks.....273
JELPFL2.....187	Disc Harrow Bearings.....274
ASPF2.....188	Hex Bore Bearings.....275
AELPF2.....189	ENGLISH/METRIC CONVERSION CHART276
JELPF2.....190	DECIMAL EQUIVALENTS277
UCF2.....191-192	
UCF3.....193-194	
UCFX.....195-196	
UELF2.....197	
UELF3.....198	
UELFU2.....199	
UKF2.....200	
Bearing Weights.....201-203	
BALL BEARING INSERT SERIES 204-221	
UC2.....204	
UC3.....205	
UCX.....206	
AS2, ASS2.....207	

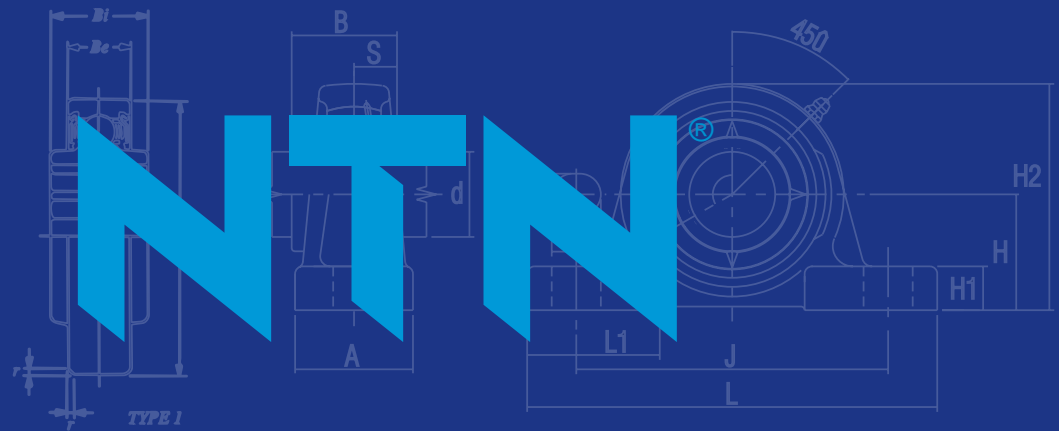

NTN Bearing Corporation of Canada

Corporate Office

305 Courtneypark Drive West
Mississauga, Ontario LSW 1 Y4
Tel: (905) 564-2700
Fax: (905) 564-9023
1-888-412-4122

Montreal Branch

4973 Levy Street
St. Laurent, Quebec H4R 2N9
Tel: (514) 333-8054
Fax: (514) 333-1078
1-888-412-4122

Toronto Branch

2880 Argentia Road, Unit #10
Mississauga, Ontario L5W 1Y4
Tel: (905) 564-9600
Fax: (905) 564-9609
1-888-412-4122

Edmonton Branch

4608 97th Street
Edmonton, Alberta T7E 5N9
Tel: (780) 435-6200
Fax: (780) 435-3600
1-888-412-4122

Vancouver

201-669 Ridley Place
Annacis Island
Delta, B.C. V3M 2Y9
Tel: (604) 517-1777
Fax: (604) 517-1794
1-888-412-4122

NTN Bearing Corporation of America

Corporate Office

1600 East Bishop Court
Mt. Prospect, IL 60056-7604
Tel: (847) 298-7500
Fax: (847) 699-9744
1-800-323-2358

Regional Sales Office

Mt. Prospect, IL
Exton, PA
Norcross, GA
Omaha, NE
Shelbyville, KY
Louisville, OH